

SAFEMAX® Zero Backlash Torque Limiters



SAFEMAX®

Contents

SAFEMAX® Zero Backlash Torque Limiters	Page
Description	73
Characteristics	74
Label code	74
<ul style="list-style-type: none">• SAFEMAX® Zero Backlash Torque Limiters SIT “GLS/SG/N”	75
<ul style="list-style-type: none">• SAFEMAX® Zero Backlash Torque Limiters SIT “GLS/SG/N” with TRASCO® ES couplings	76- 77
<ul style="list-style-type: none">• SAFEMAX® Zero Backlash Torque limiters SIT “GLS/SG/N” with SERVOPLUS® couplings	78 - 79
<ul style="list-style-type: none">• SAFEMAX® Zero Backlash Torque limiters SIT “GLS/SG/N” with SERVOMATE® couplings	80 - 81
General Information - Form	82

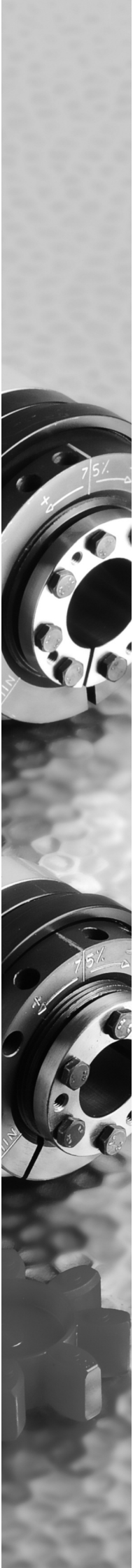

SAFEMAX® Zero Backlash Torque Limiters “GLS/SG/N”

In industrial applications, the increase of, automation in the manufacturing processes is becoming a strict requirement; performances are constantly improving. Ever the increase of precision utilizing servo systems results in the increase of higher speeds.

Moreover, in order to improve the production capacity it is also important the increase of stiffness of the systems thus the increase of the resistance to global dynamic loads.

The torque overload generated by human error, mechanical malfunction or other causes is, however, unpredictable and if not

intercepted can damage to the machine and, consequently, cause downtimes which can be long and, therefore, expensive. SAFEMAX® torque limiters prevent these problems from happening through instant disengagement of the motor side from the driven side in case of torque overload, thus eliminating the risk of expensive downtimes. In addition, our torque limiters, being torsionally rigid and backlash free, allow a rapid and accurate resumption of machine operations once the cause of the overload has been eliminated.

Features

- Backlash-free torque transmission
- Low moment of inertia
- Compact design
- Maintenance-free
- Disengagement within 1-3 milliseconds
- Easy and safe adjustment of the torque
- Re-engagement to 360° or in phase

Applications

- Machine tools
- Packaging machines
- Printing machines
- Textile Machinery
- Industrial Robots
- Cartoning machines
- Woodworking machines
- Automatic equipment

SIT torque limiters are available with regressive springs. When an overload occurs, there is an immediate disengagement of the torque limiter within a few milliseconds, saving the

machine from possible damage. When the overload ends, the torque limiter re-engages after 360° or in optional preset phases.

Graph of spring characteristic curve

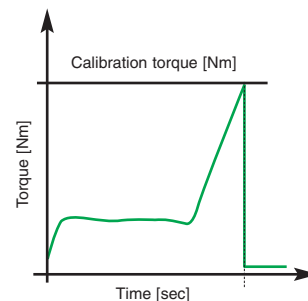
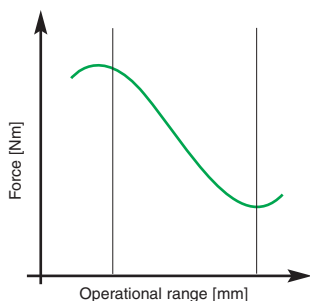





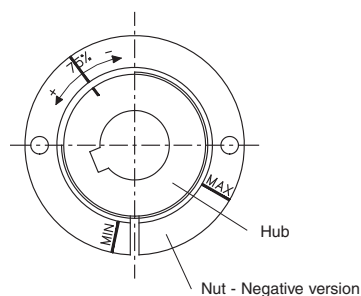
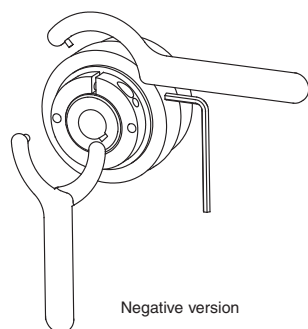

It is possible to govern the torque by the adjusting nut. Unless specifically requested, SIT limiters are designed to operate at 75% of the maximum transmissible torque. In order to allow different settings, there are reference markings on nut and hub. Moreover, there are the markings of the minimum and maximum

torque of the limiter and an indication of the direction of rotation of the nut to increase and decrease the torque of disengagement. Turning the nut clockwise the disengagement torque decreases, turning counter anticlockwise it increases.

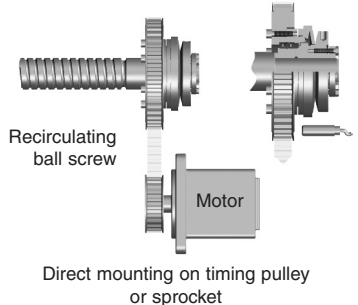

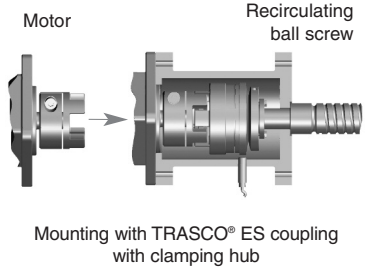
SAFEMAX®

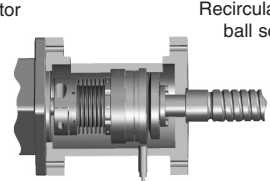
Characteristics

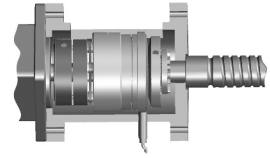
Design	Description	Characteristics	Assembly example
<p>SAFEMAX - Torque limiters</p> 	<p>For direct mounting on timing pulley or power transmission component.</p> <p>Available designs:</p> <ul style="list-style-type: none"> • With locking device shaft connection • With bore and keyway shaft connection <p>On request also available in stainless steel.</p>	<p>Transmittable torque range: from 0.7 to 720 Nm</p> <p>Sizes: from 12 to 50</p>	 <p>Recirculating ball screw</p> <p>Motor</p> <p>Direct mounting on timing pulley or sprocket</p>
<p>SAFEMAX - Torque limiters with TRASCO® ES coupling</p> 	<p>For connection of two shafts in combination with TRASCO® ES zero backlash coupling. Compensates for axial, radial and angular misalignment and absorb vibrations.</p> <p>Available designs:</p> <ul style="list-style-type: none"> • Bore and keyway both sides • Locking device - clamping hub • Locking device - shrink disc <p>On request also available in stainless steel.</p>	<p>Transmittable torque range: from 0.7 to 720 Nm</p> <p>Sizes: from 12 to 50</p>	 <p>Motor</p> <p>Recirculating ball screw</p> <p>Mounting with TRASCO® ES coupling with clamping hub</p>
<p>SAFEMAX - Torque limiters with SERVOPLUS® coupling</p> 	<p>For connection of two shafts in combination with SERVOPLUS® torsionally rigid bellows coupling. Compensates for axial, radial and angular misalignment.</p> <p>Available designs:</p> <ul style="list-style-type: none"> • Bore and keyway - clamping hub • Locking device - clamping hub <p>On request also available in stainless steel.</p>	<p>Transmittable torque range: from 0.7 to 200 Nm</p> <p>Sizes: from 12 to 35</p>	 <p>Motor</p> <p>Recirculating ball screw</p> <p>Mounting with SERVOPLUS® GSP coupling with clamping hub</p>
<p>SAFEMAX - Torque limiters with SERVOMATE® coupling</p> 	<p>For connection of two shafts in combination with SERVOMATE® torsionally rigid coupling.</p> <p>Available designs:</p> <ul style="list-style-type: none"> • Bore and keyway - clamping hub • Locking device - clamping hub <p>On request also available in stainless steel.</p>	<p>Transmittable torque range: from 0.7 to 200 Nm</p> <p>Sizes: from 15 to 25</p>	 <p>Motor</p> <p>Recirculating ball screw</p> <p>Mounting with SERVOMATE® GSM coupling with clamping hub</p>

Label code

www.sitspa.com SAFEMAX® SPGLSNA35/E-4 150Nm N13

Type: SPGLSN

Execution:

- = Torque limiter
- A = with TRASCO ES Coupling
- S = with SERVOPLUS Coupling
- M = with SERVOMATE Coupling

Size

Re-engagement:

- ... = every 360°
- /E = in equidistant phase

Number of springs

Torque

Production code

SAFEMAX® - Torque limiters “GLS/SG/N”

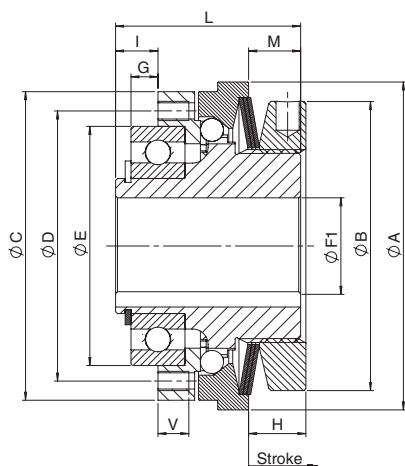

Bore and keyway execution

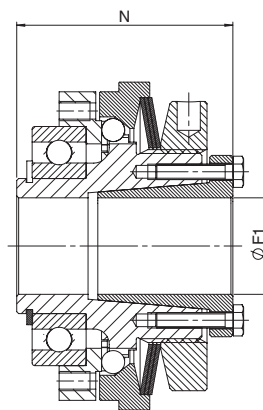

Locking device execution

Torque limiter size	Dimensions											
	F1 max [mm]	A [mm]	B [mm]	C [mm]	D [mm]	E [mm]	G [mm]	I [mm]	L [mm]	M [mm]	N [mm]	V [mm]
12	12	44	38	40	35	30	2	4,5	24	7	28,5	5
17	17	50	42	47	42	37	2	5	29	8,5	34,5	5
20	20	70	62	65	56	47	4	8	40	12	47	6
25	25	85	75	80	71	62	7	11	48	13,5	56	7
35	35*	100	82	95	85	75	9	14	59	16	67	9
42	42	115	97	110	100	90	8	16	64	17	73	10
50	50	135	117	130	116	100	6,5	18	75	20,5	86	11

*F1 : maximum diameter for finished bore with reduced keyway according to UNI 7510. Bore tolerance H7.

Torque limiter	Size		12	17	20	25	35	42	50
	Limit torques for overload		[Nm]	0,8 - 7	3 - 23	5 - 50	9 - 100	20 - 200	35 - 415
Maximum speed		[rpm]	4000	4000	4000	3000	2500	2000	1200
Thrust washer stroke on overload		[mm]	0,8	1,0	1,1	1,3	1,5	2,0	2,2

Mass moments of inertia	Nut side	Bore and keyway	[x10 ⁻⁶ kgm ²]	20	40	270	680	1510	2620	6330
		Locking device	[x10 ⁻⁶ kgm ²]	20	40	280	710	1580	2820	6820
	Pressure flange side	[x10 ⁻⁶ kgm ²]	9	15	80	290	680	1290	3150	

Weight	Bore and keyway		[kg]	0,200	0,400	0,900	1,500	2,800	3,700	6,700
	Locking device		[kg]	0,200	0,400	0,900	1,600	3,000	4,100	7,300

Screws	Nut side	N° and type	-	6 x M3	6 x M3	8 x M4	8 x M5	8 x M6	8 x M6	8 x M8
		Tightening torque	[Nm]	1,5	1,5	3,0	5,0	7,5	7,5	14,0

Springs	Torque transmissible according to the set of springs [Nm]	1N)	0,8 - 2,5	3 - 7,5	5 - 14	9 - 28	20 - 45	35 - 100	75 - 190
		2N))	2,4 - 4,5	5 - 15	12 - 28	18 - 60	42 - 95	75 - 200	140 - 345
		3N)))	3,5 - 7	8,5 - 23	24 - 50	40 - 100	-	-	-
		4N))))	-	-	-	-	85 - 200	195 - 415	245 - 720

Note:

G: installation tolerance + 0,1.
 The weights refer to the torque limiter with pilot bore.
 Inertias refer to the torque limiter with maximum bore.

SAFEMAX®

SAFEMAX® - Torque limiters “GLS/SG/N” with TRASCO® ES

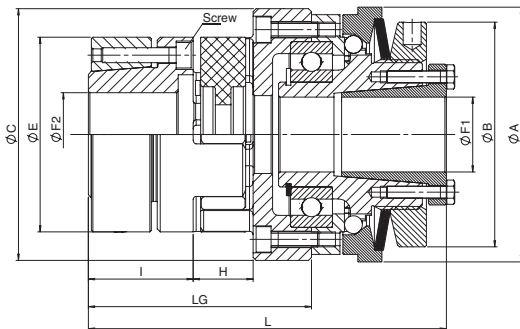

Locking device execution / GESA

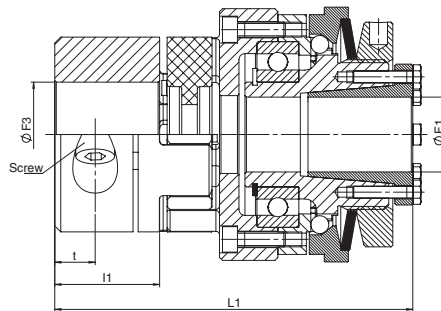

Locking device execution / GESM

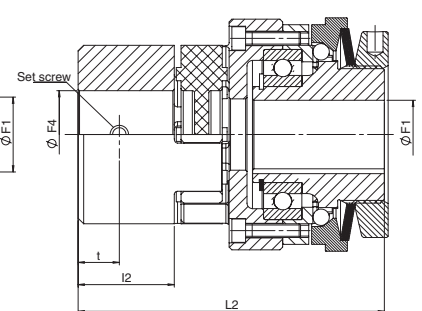

Bore and keyway execution / GESF

Torque limiter size	TRASCO® ES size	Dimensions											
		F1 max [mm]	F2 max [mm]	F3 max [mm]	F4 max [mm]	A [mm]	B [mm]	C [mm]	E [mm]	I [mm]	H [mm]	Lg [mm]	L [mm]
12	14	12	14	15	15	44	38	44	30	18,5	13	42	66
17	19/24	17	20	20	24	50	42	52	40	25	16	53	82,5
20	24/28	20	28	28	28	70	62	68	55	30	18	63	102
25	28/38	25	38	35	38	85	75	84	65	35	20	74,5	119,5
35	38/45	35*	45	45	45	100	82	100	80	45	24	93	146
42	42	42	50	50	55	115	97	115	95	50	26	100	157
50	48	50	60	55	60	135	117	138	105	56	28	110,5	178,5

*: maximum diameter for finished bore with reduced keyway according to UNI 7510.

F1, F2, F3, F4: bore tolerance H7.

Torque limiter	Size		12	17	20	25	35	42	50
	Limit torques for overload		[Nm]	0,8 - 7,5	3 - 23	5 - 50	9 - 100	20 - 200	35 - 415
Maximum speed		[rpm]	4000	4000	4000	3000	2500	2000	1200
Thrust washer stroke on overload		[mm]	0,8	1	1,1	1,3	1,5	2	2,2

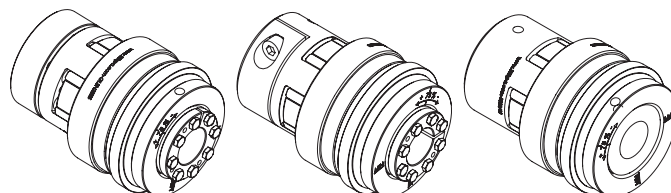

TRASCO ES® coupling	Size			14	19/24	24/28	28/38	38/45	42	48
	Nominal torque	92 Sh A 98 Sh A 64 Sh D	[Nm]	7,5	10	35	95	190	265	310
				12,5	17	60	160	325	450	525
				16	21	75	200	405	560	655
	Maximum torque	92 Sh A 98 Sh A 64 Sh D	[Nm]	15	20	70	190	380	530	620
				25	34	120	320	650	900	1050
				32	42	150	400	810	1120	1310
	Maximum axial misalignment	92 Sh A 98 Sh A 64 Sh D	[mm]	1,0	1,2	1,4	1,5	1,8	2,0	2,1
				1,0	1,2	1,4	1,5	1,8	2,0	2,1
				1,0	1,2	1,4	1,5	1,8	2,0	2,1
Maximum radial misalignment	92 Sh A 98 Sh A 64 Sh D	[mm]	0,15	0,10	0,14	0,15	0,17	0,19	0,23	
			0,09	0,06	0,10	0,11	0,12	0,14	0,16	
			0,06	0,04	0,07	0,08	0,09	0,10	0,11	
Maximum angular misalignment	92 Sh A 98 Sh A 64 Sh D	[°]	1,0	1,0	1,0	1,0	1,0	1,0	1,0	
			0,9	0,9	0,9	0,9	0,9	0,9	0,9	
			0,8	0,8	0,8	0,8	0,8	0,8	0,8	

Mass moments of inertia	Pressure flange side	Bore and keyway		[x10 ⁶ kgm ²]	20	40	270	680	1510	2620	6330
		Locking device			20	40	280	710	1580	2820	6820
	Hub side	GESF - Bore and keyway			23	61	228	763	1747	6303	13434
		GESM - Clamping hub			23	59	252	727	1812	7152	14808
		GESA - Shrink disc			27	71	312	878	2306	7207	14848

Weight	Combinations			Total weight							
	Torque limiters	Coupling	[kg]								
	Bore and keyway	GESF		0,269	0,543	1,190	2,028	3,715	7,061	11,453	
	Clamping device	GESM		0,267	0,548	1,214	2,115	3,900	7,561	12,433	
Clamping device	GESA	0,298		0,597	1,338	2,325	4,410	7,761	12,613		

Screws	Clamping device torque limiter	N° and type	-	6 x M3	6 x M3	8 x M4	8 x M5	8 x M6	8 x M6	8 x M8
		Tightening torque	[Nm]	1,5	1,5	3,0	5,0	7,5	7,5	14,0
	GESF - Set screw	Type	-	M4	M5	M5	M6	M8	M8	M8
		Tightening torque	[Nm]	1,5	2,0	2,0	4,0	10,0	10,0	10,0
	GESM - Clamping screw	Type	-	M3	M6	M6	M8	M8	M10	M12
		Tightening torque	[Nm]	1,3	11,0	11,0	25,0	25,0	70,0	120,0
GESA - Shrink disc screws	N° and type (12.9)	-	4 x M3	6 x M4	4 x M5	8 x M5	8 x M6	4 x M8	4 x M8	
	Tightening torque	[Nm]	1,3	2,9	6,0	6,0	10,0	35,0	35,0	

TRASCO® ES Coupling Shrink Disc Transmissible Torque																									
Type		Transmissible torque [Nm] related to shaft diameter [mm]																							
Torque limiters	Coupling	10	11	14	15	16	17	18	19	20	22	24	25	28	30	32	35	38	40	42	45	48	50	55	60
12	19/24	48	53	67	72	77	81	86	91	96															
17	24/28				77	82	88	93	98	103	113	124	129	144											
20	28/38							186	196	206	227	247	258	289	309	330	361	392							
25	38/45									291	320	349	364	408	437	466	510	553	582	612	655	699			
35	42													345	584	623	681	740	779	818	876	934	973	1071	
50	48																681	740	779	818	876	934	973	1071	1168

Notes:

The data are related to application with red AES spider 98 Sh A. The weights refer only to applications with coupling with pilot bore. Inertias refer to applications with couplings with maximum bore.

SAFEMAX® - Torque limiters “GLS/SG/N” with SERVOPLUS®

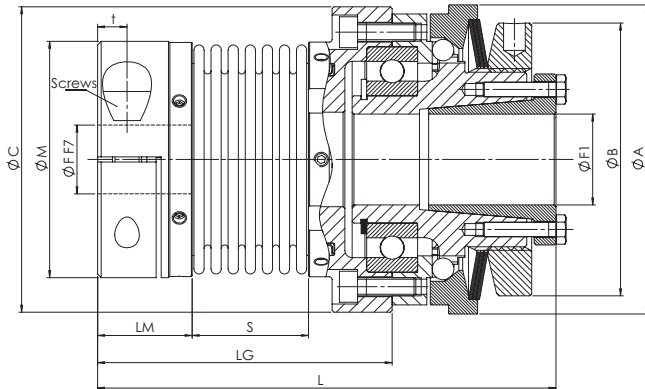

Locking device execution / GSP

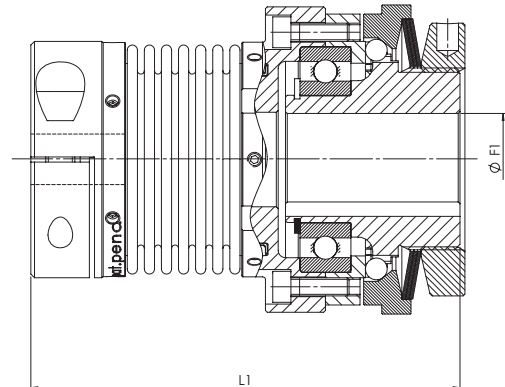

Bore and keyway execution / GSP

Torque limiter size	SERVOPLUS® Size	Dimensions												
		F min [mm]	F max [mm]	F1 max [mm]	A [mm]	B [mm]	C [mm]	M [mm]	L _m [mm]	S [mm]	L _g [mm]	L [mm]	L ₁ [mm]	
12	16	5	16	12	44	38	43	34	17	16,5	48	72	67,5	
17	20	8	20	17	50	42	49	40	20,5	21	58	87,5	82	
20	30	10	30	20	70	62	65	55	22,5	27	69	108	101	
25	38	14	38	25	85	75	84	65	26	32	81	126	118	
35	45	14	45	35*	100	82	104	83	31	41	102	155	147	

F: bore tolerance F7.

F1: bore tolerance H7.

*: maximum diameter for finished bore with reduced keyway according to UNI 7510.

Torque limiter	Size		12	17	20	25	35	
	Limit torques for overload		[Nm]	0,8 - 7	3 - 23	5 - 50	9 - 100	20 - 200
	Maximum speed		[rpm]	4000	4000	4000	3000	2500
	Thrust washer stroke on overload		[mm]	0,8	1,0	1,1	1,3	1,5

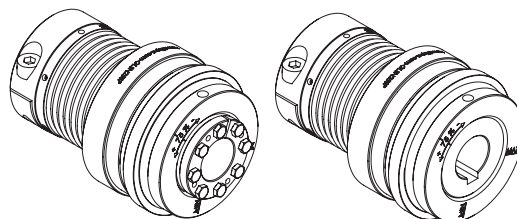

SERVOPLUS® coupling	Size		16	20	30	38	45
	Nominal torque	[Nm]	5	15	35	65	150
	Maximum torque	[Nm]	10	30	70	130	300
	Maximum axial misalignment	[mm]	-/+0,5	-/+0,6	-/+0,8	-/+0,8	-/+1,0
	Maximum radial misalignment	[mm]	0,20	0,20	0,25	0,25	0,30
Maximum angular misalignment	[°]	1,5	1,5	2,0	2,0	2,0	

Mass moments of inertia	Pressure flange side	Bore and keyway	[x10 ⁴ kgm ²]	16	20	30	38	45
		Locking device		20	40	270	680	1510
	Hub side	Clamping hub		28	55	248	726	2152

Weight	Combinations			Total weight				
	Torque limiters	Coupling	[kg]					
	Bore and keyway	Clamping hub		0,290	0,539	1,212	2,004	3,870
	Locking device	Clamping hub		0,290	0,539	1,212	2,104	4,070

Screws	Clamping device torque limiter	N° and type	-	6 x M3	6 x M3	8 x M4	8 x M5	8 x M6
		Tightening torque	[Nm]	1,5	1,5	3,0	5,0	7,5
	GSP - Bellows set screw	Type	-	4 x M3	4 x M3	4 x M4	6 x M4	6 x M5
		Tightening torque	[Nm]	0,8	0,8	2,0	2,0	3,8
	Clamping screw	Type	-	M4	M5	M6	M8	M10
		Tightening torque	[Nm]	2,9	6,0	10,0	25,0	49,0

SAFEMAX®

SERVOPLUS® Coupling Clamping Hub Transmissible Torque																									
Type		Transmissible torque [Nm] related to shaft diameter [mm]																							
Torque limiters	Coupling	5	6	7	8	9	10	11	12	14	15	16	18	19	20	24	25	28	30	32	35	38	40	42	45
12	16	5	6	7	8	9	10	11	12	14	15	16													
17	20				13	14	16	18	19	22	24	25	29	30	32										
20	30							25	27	32	34	36	41	43	45	54	57	63	68						
25	38												75	79	83	100	104	116	124	133	145	158			
35	45														132	158	165	183	198	211	231	248	263	277	295

Notes:
 The data are related to applications with pilot bore coupling.
 The weights refer only to application with couplings with pilot bore.

SAFEMAX® - Torque limiters “GLS/SG/N” with SERVOMATE®

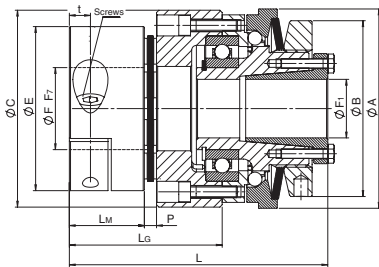

Locking device execution / GSM

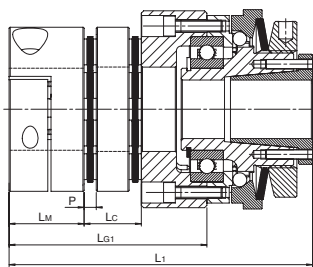

Locking device execution / GSMC

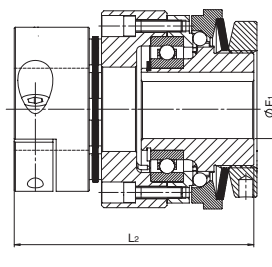

Bore and keyway execution / GSM

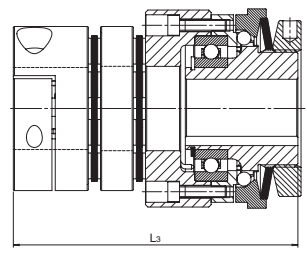

Bore and keyway execution / GSMC

Torque limiter size	SERVOMATE® Size	Dimensions														
		F max [mm]	F1 max [mm]	A [mm]	B [mm]	C [mm]	E [mm]	Lm [mm]	P [mm]	Lc [mm]	Lg [mm]	Lg1 [mm]	L [mm]	L1 [mm]	L2 [mm]	L3 [mm]
17	15	20	17	50	42	52	47	21	3	13	40	50	69,5	79,5	64	74
20	20	25	20	70	62	68	59	24	4	19	48	63	87	102	80	95
25	25	35	25	85	75	84	70	32	5	24	65	84	110	129	102	121

F: bore tolerance F7.
F1: bore tolerance H7.

Torque limiter	Size				
	17	20	25		
	Limit torques for overload	[Nm]	3 - 23	5 - 50	9 - 100
	Maximum speed	[rpm]	4000	4000	3000
Thrust washer stroke on overload	[mm]	1,0	1,1	1,3	

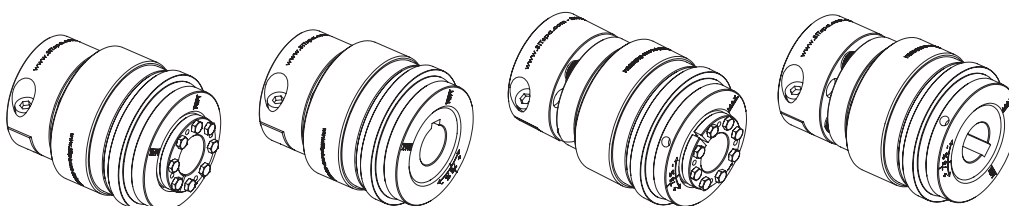

SERVOMATE® coupling	Size		Standard			With spacer		
			15	20	25	15	20	25
	Nominal torque	[Nm]	20	30	60	20	30	60
Maximum torque	[Nm]	40	60	120	40	60	120	
Maximum axial misalignment	[mm]	0,5	0,6	0,8	1,0	1,2	1,6	
Maximum radial misalignment	[mm]	-	-	-	0,16	0,25	0,30	
Maximum angular misalignment	[°]	1,0	1,0	1,0	1,0	1,0	1,0	

Mass moments of inertia	Pressure flange side	Bore and keyway	[x10 ⁴ kgm ²]	40	270	680	40	270	680
		Locking device		40	280	710	40	280	710
	Hub side	Clamping hub		70	272	838	82	318	950

Weight	Combinations			Total weight					
	Torque limiters	Coupling	[kg]						
	Bore and keyway	Clamping hub		0,556	1,218	2,090	0,594	1,310	2,247
Locking device	Clamping hub	0,556		1,218	2,190	0,594	1,310	2,347	

Screws	Clamping device torque limiter	N° and type	-	6 x M3	8 x M4	8 x M5
		Tightening torque	[Nm]	1,5	3,0	5,0
	Clamping screw	Type	-	M6	M6	M8
		Tightening torque	[Nm]	10,0	10,0	25,0

SAFEMAX®

SERVOMATE® Coupling Clamping Hub Transmissible Torque																
Type		Transmissible torque [Nm] related to shaft diameter [mm]														
Torque limiters	Coupling	Ø10	Ø11	Ø12	Ø14	Ø15	Ø16	Ø19	Ø20	Ø22	Ø24	Ø25	Ø28	Ø30	Ø32	Ø35
17	15	20	22	24	28	30	32	38	40	-	-	-	-	-	-	-
20	20	-	-	24	28	30	32	38	40	44	48	50	-	-	-	-
25	25	-	-	-	-	55	59	70	73	81	88	92	103	110	117	128

Notes:
 The data are related to applications with pilot bore coupling.
 The weights refer only to application with couplings with pilot bore.

General Information

Company Name
address

Contact Information

First Name address	Last Name
Job Title Phone	Email address

Requested quantity

Annual expected quantity

Application

Application field

Type of machine
Where the Torque limiter will be applied and whats to be protected

Rated torque (Nm)
Speed (Rpm)

Work Environment

Clean
Presence of dust
Presence of oil
humidity%
other elements

Re-engagement position

equidistant
360°
Not important
other

Transmission type

parallel
coaxial

Motor shaft diameter (mm)

Shaft connection type
Bore and keyway
Clamping ring
other

Type of component (Gear, sprocket, Parallel Transmission)

Type of coupling (coaxial Transmission)
Driven shaft diameter (mm)
Connection type driven shaft
bore and keyway
Clamping ring
Other

Notes

Please attach application drawing