

## **KS PERMAGLIDE® P14 plain bearings**

**Maintenance-free and environmentally friendly, for dry-running applications, unleaded, compliant with Directive 2000/53/EC (End of Life Vehicles Directive) and 2011/65/EU (RoHS II –Restriction of Hazardous Substances Directive).**





### **Motorservice**

The Motorservice Group is the sales organisation for the global aftermarket activities of KSPG (Kolbenschmidt Pierburg). It is one of the leading suppliers of engine components for the independent aftermarket, including the premium brands KOLBENSCHMIDT, PIERBURG and TRW Engine Components, as well as the BF brand.



### **KS Gleitlager**

Within the Kolbenschmidt Pierburg Group, KS Gleitlager is the specialist for high-precision bearings. The introduction of new technologies in production and surface finishing, innovative material developments and a clear customer focus have made KS Gleitlager one of the world's leading suppliers of engine plain bearings and dry plain bearings (KS PERMAGLIDE®).



### **KSPG (Kolbenschmidt Pierburg)**

As long-standing partners to the automotive industry, the companies in the KSPG Group develop innovative components and system solutions with acknowledged competence for air supply and emission control, for oil and water pumps, for pistons, engine blocks and engine bearings. The products comply with the high demands and quality standards of the automotive industry. Low emission, reduced fuel consumption, reliability, quality and safety – these are the forces that drive innovation at KSPG.

**PERMAGLIDE® is a registered trademark of KS Gleitlager GmbH**

1st edition 06.2015  
Item no. 50 003 851-02

**Editorial department:**  
Motorservice, Product Management

**Layout and production:**  
Motorservice, Marketing  
DIE NECKARPRINZEN GmbH, Heilbronn

This document must not be reprinted, duplicated or translated in full or in part without our prior written consent and without reference to the source of the material.

All content including pictures and diagrams is subject to alteration. No liability accepted.

**Published by:**  
© MS Motorservice Deutschland GmbH

### **Liability**

All information in this brochure has been carefully researched and compiled. Nevertheless, it is possible that errors have occurred, information has been translated incorrectly, information is missing or the details provided have changed in the intervening time. As a result, we are unable to provide any guarantee nor to accept any legal liability for the accuracy, completeness, currency or quality of the information provided. We hereby waive all liability for any damages, whether direct or indirect in nature and whether tangible or intangible, resulting from the use or misuse of information or from incomplete or incorrect information in this brochure, unless proven to be the result of deliberate intent or negligence on our part.

The parts outlined in the catalogue are not designed for use in aircraft. Names, descriptions and numbers of products, manufacturers, etc. are included for the purpose of comparison only.

## 1. Description of material

KS PERMAGLIDE® P14 was designed as unleaded bearing material for dry-running applications. The composite, multi-layered material offers a low and consistent friction coefficient over the entire runtime. Besides excellent tribological characteristics in dry running, the material can also be easily used in oil-lubricated and grease-lubricated environments.

KS PERMAGLIDE® P14 has a broad range of applications and is used anywhere where the use of leaded materials is not permitted, for instance in the

- chemicals industry
- food industry
- packaging industry and
- in the pharmaceutical industry.

KS PERMAGLIDE® P14 offers the following advantages over comparable leaded plain bearing products:

- Higher chemical resistance
- Highly suitable for use in an oil-lubricated or grease-lubricated environment
- Very low swelling tendency
- Physiologically harmless
- In compliance with the Directives 2000/53/EC (End of Life Vehicles Directive) 2002/95/EC (RoHS) and 2011/65/EU (RoHS II)

A precisely adapted metal-plastic compound system is essential to maintain these characteristics. As a friction-reducing plastic, polytetrafluoroethylene (PTFE) is

used with mineral additives of zinc sulphide (ZnS). In this composition, the mineral proportion offers special characteristics for oil-lubricated application. Thus the material is able to take oil into its structure in order to release it back into the bearing position, e.g. in the case of inadequate lubrication. This effect occurs without any notable change to the material dimensions and thus does not influence the operating clearance for the bearing.



# KS PERMAGLIDE® P14 plain bearings – maintenance-free and environmentally friendly

## 2. Material composition

Spherical sintered bronze is firmly bonded on a stiff steel back. The cavities between the bronze spheres are completely filled with the solid lubricant and applied as a running-in layer to cover the bronze.

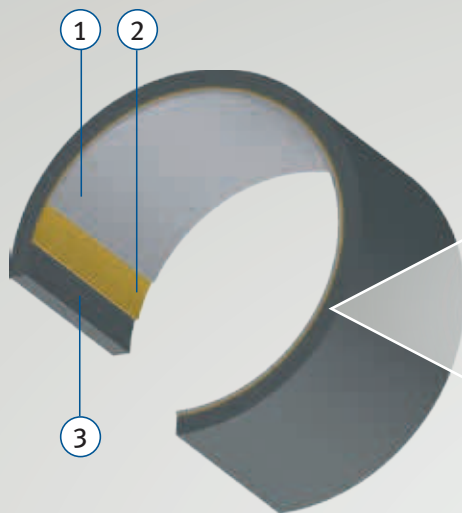

Fig. 1: Layer system

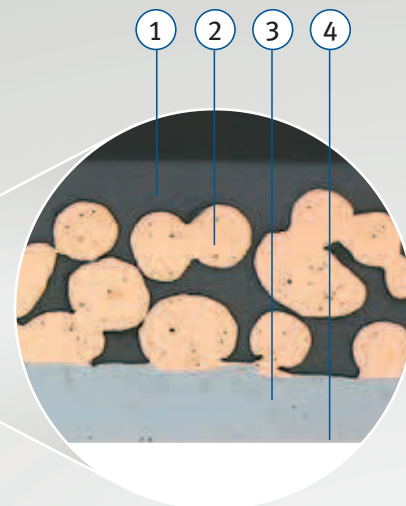

Fig. 2: Enlarged cross section in new condition

1	Running-in layer	
	PTFE matrix with bulking agent <sup>1)</sup>	
	Layer thickness [mm]:	max. 0.03
2	Sliding layer	
	Tin-bronze	
	Layer thickness [mm]:	0.20–0.35
	Pore volume [%]:	approx. 30
3	Bearing back	
	Steel	
	Steel thickness [mm]:	Variable
	Steel hardness [HB]:	100–180

Tab. 1: Material composition

- 1 Running-in layer / surface layer  
Solid lubricant made from PTFE and zinc sulphide
- 2 Sliding layer made from spherical sintered bronze
- 3 Bearing back made from steel
- 4 Corrosion protection made from tin

<sup>1)</sup> The pores of the sliding layer are also filled with this lubricant mass.

### 3. Principle of operation

For example, a radial-loaded cylindrical plain bearing bush in a rotational pattern of movement is observed (Fig. 3). In the running-in phase, a closed lubricating film is applied over the interacting sliding partner if possible. In doing so, the surfaces are equalised, the friction coefficient is adjusted and the interacting sliding partner is impregnated. The material removal is between 0.005 and 0.030 mm. The bronze layer then begins to function (Fig. 4).

High load-bearing strengths up to the yield point of the bronze are possible. The superposition of the movement leads to mixed

loads. Here, the bearing has to tolerate the resulting frictional heat. The frictional heat must be dissipated via the shaft and the housing. The increase in temperature leads automatically to thermal expansion of the plastic, ensuring corresponding subsequent lubrication of the interacting sliding parts. This process is repeated, provided that sufficient solid lubricant is available and the bearing operates in the thermal equilibrium. The end of the operating life is characterised by a large bearing clearance, a higher friction coefficient and an unavoidably higher bearing temperature.



*Fig. 3: Material transfer*  
 1 Initial condition  
 2 End of running-in process



*Fig. 4: Condition at end of running-in process. The bronze layer begins to function.*

# KS PERMAGLIDE® P14 plain bearings – maintenance-free and environmentally friendly

## 4. Technical data

The operating limits of plain bearings are described in so-called pv value diagrams. The product of surface pressure and circumferential speed is equivalent to the input power per bearing surface. If the operating point lies within the green curve, then the KS PERMAGLIDE® P14 can generally be used.

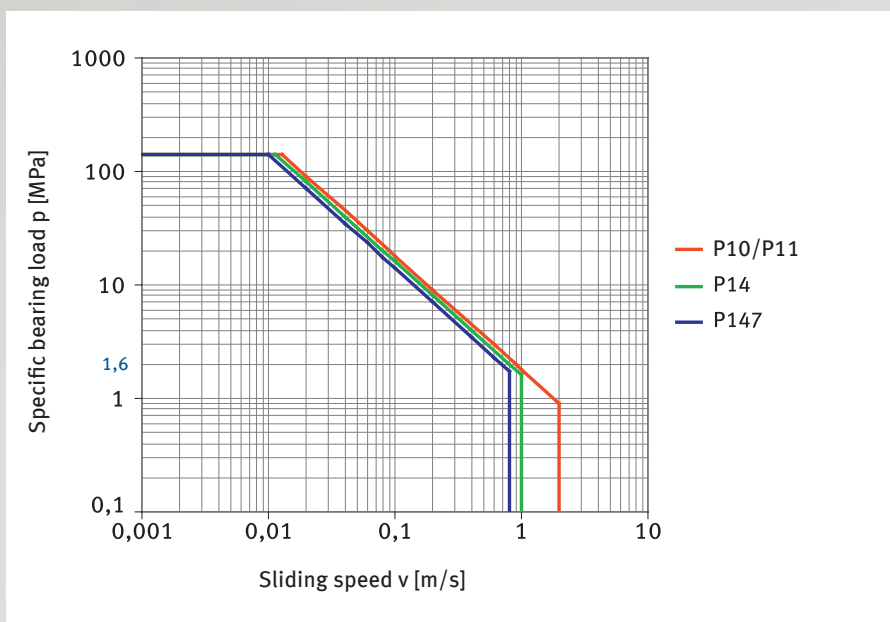

Fig. 5: pv value [MPa·m/s], limit curve (values apply at room temperature)

Where the permissible load limit is exceeded for a static load type or in the event of very low speeds, there is most often a failure due to material deformation. At high speeds and moderate loads, on the contrary, plain bearings are under even more thermal stress. Beyond the curves, thermal equilibrium is not established in the plain bearing, which can lead to the materials melting.

Characteristic values, load limit	Designation	Unit	Value
Permitted pv value	$p_{v_{max}}$	MPa·m/s	1.6
Permitted specific bearing load			
• Static	$p_{max}$	MPa	250
• Concentrated load, circumferential load at a sliding speed of $\leq 0.011$ m/s	$p_{max}$	MPa	140
• Concentrated load, circumferential load at a sliding speed of $\leq 0.029$ m/s	$p_{max}$	MPa	56
• Concentrated load, circumferential load, increasing at a sliding speed of $\leq 0.057$ m/s	$p_{max}$	MPa	28
Permitted sliding speed			
• Dry running	$v_{max}$	m/s	1
• Hydrodynamic operation	$v_{max}$	m/s	3
Permitted temperature	$T_{max}$	°C	-200 to +280
Coefficient of thermal expansion			
• Steel back	$\alpha_{St}$	K <sup>-1</sup>	$11 \cdot 10^{-6}$
Coefficient of thermal conductivity			
• Steel back	$\lambda_{St}$	W(mK) <sup>-1</sup>	40

Tab. 2: Material characteristics

## 5. Practical applications

### Franking and inserting machines

Franking and inserting require a multitude of precise movements, e.g. addition and removal of envelopes and paper as well as the process of folding paper. The bearing positions are mostly subject to an oscillating movement. Cylindrical plain bearing bushes made from unleaded KS PERMAGLIDE® P14 are used for transport shafts and rollers, for example. The material is highly suitable for bearings due to its low wear and low operating bearing clearance.

Due to weight and installation space, the sintered bronze bushes previously used in the application were almost completely replaced by slim KS PERMAGLIDE® plain bearing bushes. The all-plastic plain bearings used previously are too easily worn and do not guarantee sufficient protection against fractures.

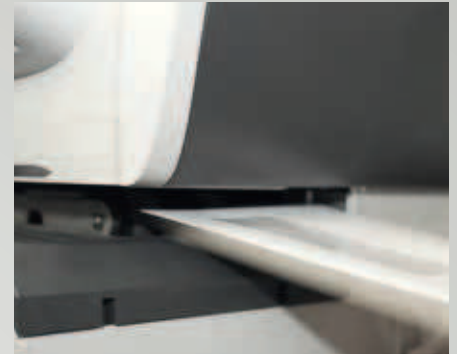

Fig. 6: Franking machine application

### Matrix printer

If duplicates are required, e.g. for prescriptions at a medical practice or for delivery notes in logistics, matrix printers are still used. Here, the ribbon is generally transported via a gear. The compact design of the printer requires miniature plain bearings with low space requirements. Lubrication has not been used in this application as paper dust and grease can combine to form a paste. The friction coefficient is therefore

disrupted and consequently, there is a negative impact on the drive motor. With dry running, however, it was possible to make the motor smaller. In this application, the previously used sintered bearings were replaced by KS PERMAGLIDE® P14 plain bearings, meaning the manufacturing costs could be reduced even further.



Fig. 7: Matrix printer application

P14 is compliant with Directive  
2011/65/EU (RoHS II).

# KS PERMAGLIDE® P14 plain bearings – maintenance-free and environmentally friendly

## Throttle bodies

The pivoting movement in PIERBURG throttle bodies is achieved with the KS PERMAGLIDE® P14 plain bearing. The material is exposed to maximum operating temperatures of  $-40^{\circ}\text{C}$  to  $+140^{\circ}\text{C}$ . A high

level of durability is required of the material, even greater than the durability of a vehicle (approx. 15 years). This corresponds to  $7.5 \times 10^6$  switching cycles with simultaneous temperature coverage.



Fig. 8: Throttle body application

## Fuel pumps

KS PERMAGLIDE® P14 plain bearings are used in fuel pumps for the shaft bearing of the electric motor.

Due to the high level of chemical resistance of the bearing material, direct contact with fuels does not have any negative effects. The speed and bearing clearance were

selected so that a hydrodynamic lubricating film can form between the shaft and the plain bearing. As a result, friction is minimal and the material stays wear-free. The bearing clearance remains constant, as KS PERMAGLIDE® P14 is not corroded by hydrocarbons and does not exhibit any swelling.

For switch-on and switch-off operations, the plain bearing undergoes mixed friction operation, whereby KS PERMAGLIDE® P14 can benefit from its intake ability.

KS PERMAGLIDE® P14 also offers outstanding (emergency) runnability for possible dry running of a pump.

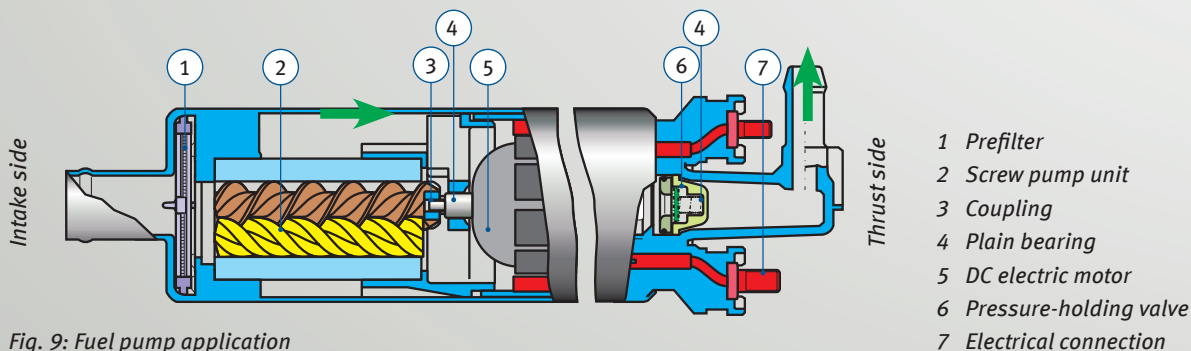

Fig. 9: Fuel pump application

As part of Directive 2000/53/EC (End of Life Vehicles Directive), leaded materials were replaced by unleaded materials as far as possible. KS PERMAGLIDE® P14 plain bearings fulfil the requirements of the directive and are used as standard in many components for the automotive industry.



**Vacuum pumps and vane pumps**

Functional principles, e.g.

- Single-shaft rotary vane pumps
- Double-shaft eccentric pumps
- Claw pumps
- Screw pumps

KS PERMAGLIDE® P14 plain bearing bushes are used, for example, in oil-lubricated single-shaft rotary vane pumps, in pairs as the main bearing of the rotary slide shaft.

The fault-free hydrodynamic operation requires, amongst other aspects, a precise operating clearance for the bearing, which is matched to the oil.

The KS PERMAGLIDE® P14 material is resistant to all oils and maintains its dimensions. The excellent cavitation stability also makes the P14 material suitable for high-speed applications.

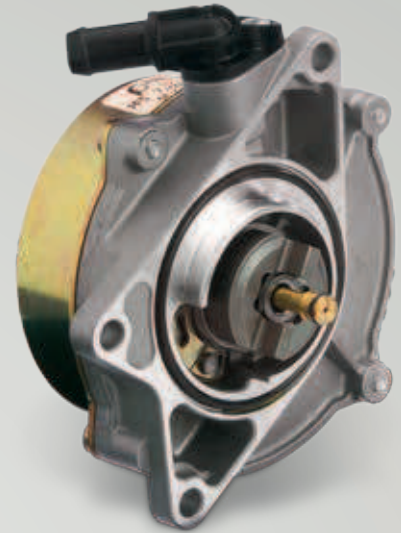

Fig. 9: Vacuum pump

**Proportional solenoid**

Proportional solenoids are electromagnetic actuators for small strokes. They convert electrical energy into proportional mechanical energy. In the process, KS PERMAGLIDE® P14 plain bearings guide the rotor at a very low bearing clearance.

The plain bearing must possess a low and, above all, consistent friction coefficient over the course of the entire operating life in order to minimise energy loss and keep the hysteresis low.

The ferromagnetic characteristic of the steel back is also significant.

Due to the antistatic characteristic of the KS PERMAGLIDE® P14, there is no electrical charging through which dust could be drawn in.

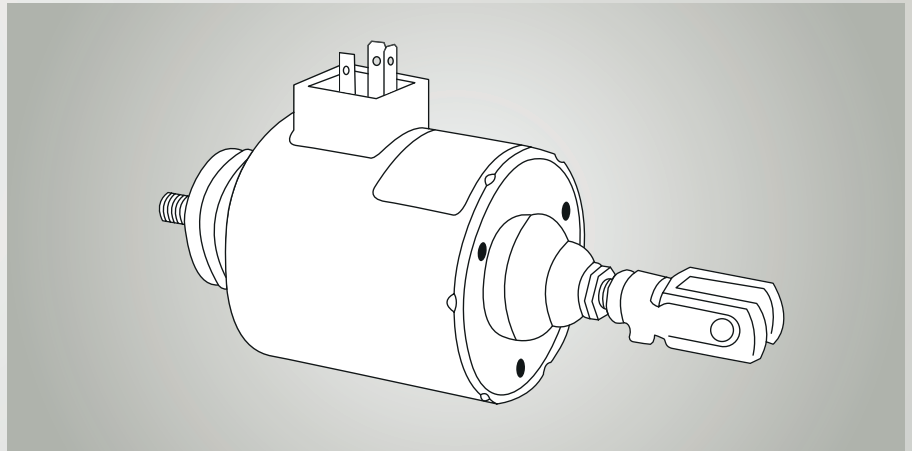

Fig. 10: Proportional solenoid application

# KS PERMAGLIDE® P14 plain bearings – maintenance-free and environmentally friendly

## 6. Application parameters

During dry running, it must be ensured that the tribological pairing does not result in galvanisation. When using a galvanised shaft, the zinc layer, for instance, can be worn away relatively quickly, meaning that the shaft rusts in the area of the plain bearing. Hard, loose rust particles have an abrasive effect on the bearing and can provoke galvanic corrosion, which is known as tribochemical wear.

With regard to the durability, it is essential to ensure that the surrounding area is clean. Simple sealing systems, e.g. for shafts with gland packings or gap seals, can significantly increase the operating life. In spite of a certain embedding capacity, the KS PERMAGLIDE® P14 plain bearing must be protected against any abrasive particulates. Sand, chips or hard, metallic particulates can damage the shaft early on.

Almost all oils and greases are suitable for use with KS PERMAGLIDE® P14 plain bearings. If the pH value drops below 4, corrosion can occur on the bronze.

The material KS PERMAGLIDE® P14 should not come into contact with water. Due to the material's capillary behaviour, the water may diffuse from the sliding surface to the steel back and cause corrosion damage.

The operational safety and durability of KS PERMAGLIDE® P14 plain bearings depend to a large extent on the condition of the interacting sliding partner. Good conditions are ensured by the use of hardened or hard chrome-plated steel or hard-anodised aluminium. The counter sliding surface should have a hardness of at least HRC50, as a relatively hard bronze is used in the KS PERMAGLIDE® P14.

The surfaces of the interacting sliding partners should be thoroughly polished and have a roughness (Rz) in the range of 0.8 to 1.5 µm.

Plain bearing bushes in accordance with DIN ISO 3547 are available as low-cost catalogue goods. Furthermore, Motorservice offers modified standard designs and customised components made from KS PERMAGLIDE® materials.

Do you need assistance with designing your plain bearings?  
Your Motorservice contact persons offer you application-based advice and calculations.

## 7. KS PERMAGLIDE® P1 – models



*PAP bushes*  
P10, P11, P14, P147\*



*PAF flange bushes*  
P10, P11, P14, P147\*



*PAW thrust washers*  
P10, P11, P14, P147\*

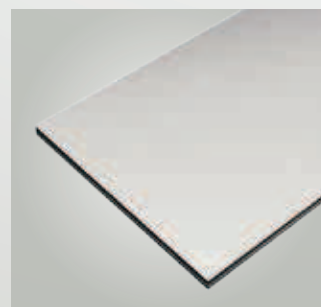

*PAS strips*  
P10, P11, P14, P147\*

\* On request

## 8. Motorservice – Your premium supplier

### Sales support and technical customer service

- Expert advice for order and delivery processing
- Online catalogue with calculation tool, CAD drawings and 3D views
- Product catalogues and product information – on request as personalised version with your address and logo
- Sales promotion: trade fair presentations, product samples, promotional items and give-aways
- Always stay up to date with our newsletter and website: [www.permaglidge.de](http://www.permaglidge.de)

- Individual advice, calculations and plain bearing design
- Special designs according to your requirements

### Our experience is your gain

- Over 30 years of expertise in the manufacture of KS PERMAGLIDE® plain bearings
- Top quality standards of the German automotive industry
- Practical test rigs according to your requirements
- Material and process development

### Logistics performance

- High availability and warehouse storage
- Quick order processing and commissioning
- Cost-optimised delivery at a given deadline or overnight via express delivery

Consistently high quality

100% made in Germany

Comprehensive technical service

KS PERMAGLIDE® Plain Bearings – For perfect running.



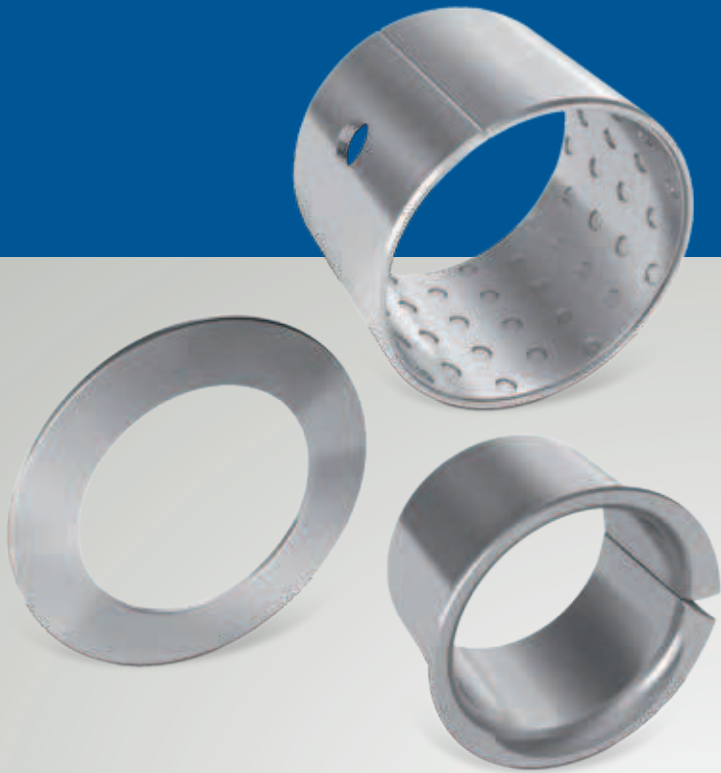

**Original**  
**KS PERMAGLIDE®**  
**plain bearings**

KS PERMAGLIDE® Partner:

International Sales:

**MS Motorservice International GmbH**

Hamburger Straße 15

41540 Dormagen, Germany

Phone: +49 2133 267-130

Fax: +49 2133 267-333

[www.ms-motorservice.com](http://www.ms-motorservice.com)

Production:

**KS Gleitlager GmbH**

Am Bahnhof 14

68789 St. Leon-Rot, Germany

Phone: +49 6227 56-0

Fax: +49 6227 56-302

[www.kspg.com](http://www.kspg.com)

