

Linear guideways

CG series

3.3 CG series

3.3.1 Properties of the linear guideways, series CG

The HIWIN linear guideways of the CG series with 0-arrangement of the ball tracks guarantee high torque loading capacity, especially in the M_x direction. The modified track geometry ensures high load ratings. The new flexible end seal automatically adjusts itself to the rail contour and ensures a high, permanent dust protection.

To protect the end seal against mechanical damage, the CG series is equipped with a sheet metal scraper in front of the end seal as standard.

Optionally, a cover strip is available – the entry of dust and wear of the sealing lip are thus permanently reduced to a minimum. With the help of a mounting tool the cover strip is installed in a few easy steps.

For optimum lubricant distribution the block has an additional lubrication path which leads the lubricant into the middle of the carrying zone. This ensures long relubrication intervals and a significant advantage especially in short stroke applications.

3.3.2 Design of the CG series

Free of play 4-row recirculation ball bearing guide with best dust protection already in the standard version.

Easy mounting, better protection against entry of dust and against wear of the end seal due to cover strip.

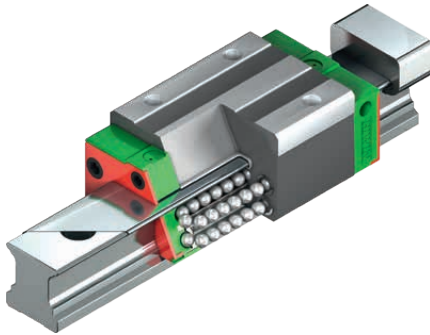

Optimized lubrication concept for long relubrication intervals and short stroke applications.

0-arrangement and optimized geometry of ball bearing guide for high torque loading capacity and high load ratings.

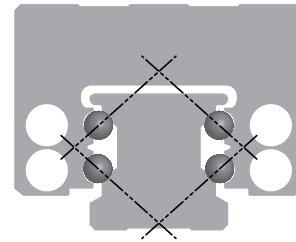
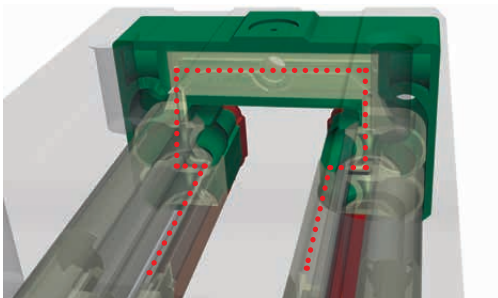

Advantages:

- Free of play
- Interchangeable
- High accuracy
- High torque loading capacity, especially rolling moment M_x
- Optional with cover strip

3.3.3 Order codes for the CG series

For CG linear guideways, a distinction is made between fully assembled and unmounted models. The dimensions of both models are the same. The main difference is that the block and rail in the unmounted models can be freely interchanged. Block and rail can be ordered separately and fitted by the customer. Their accuracy extends to class P.

Order code for linear guideway (fully assembled)

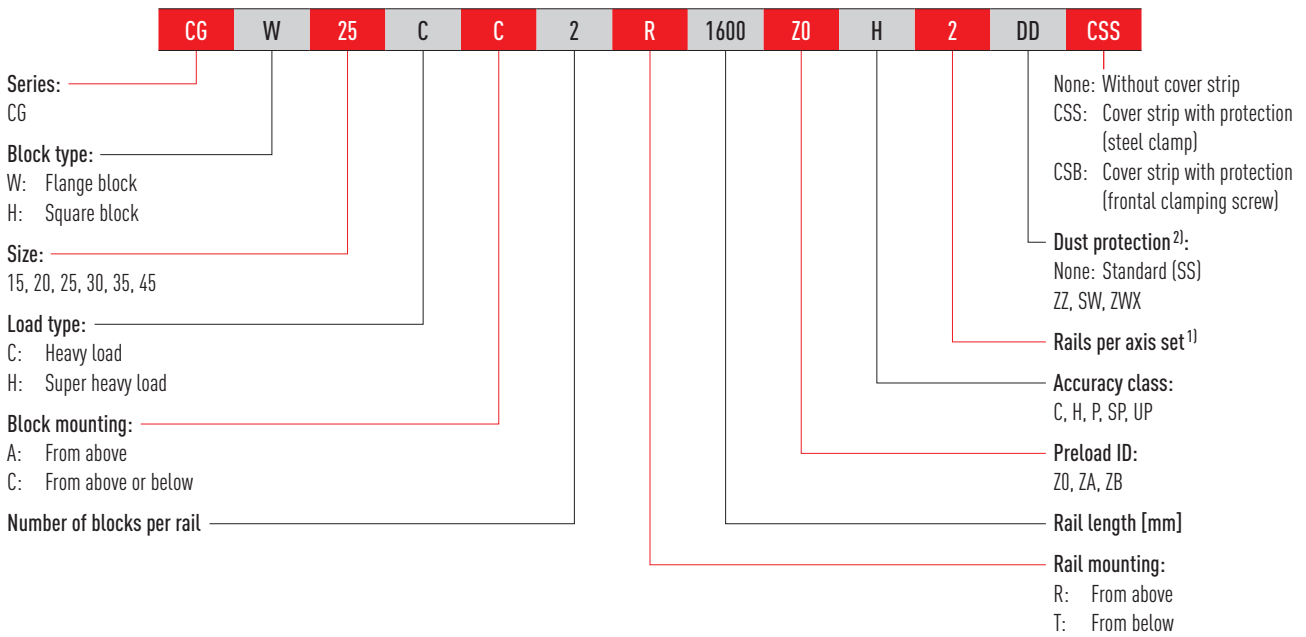

Order code for block (unmounted)

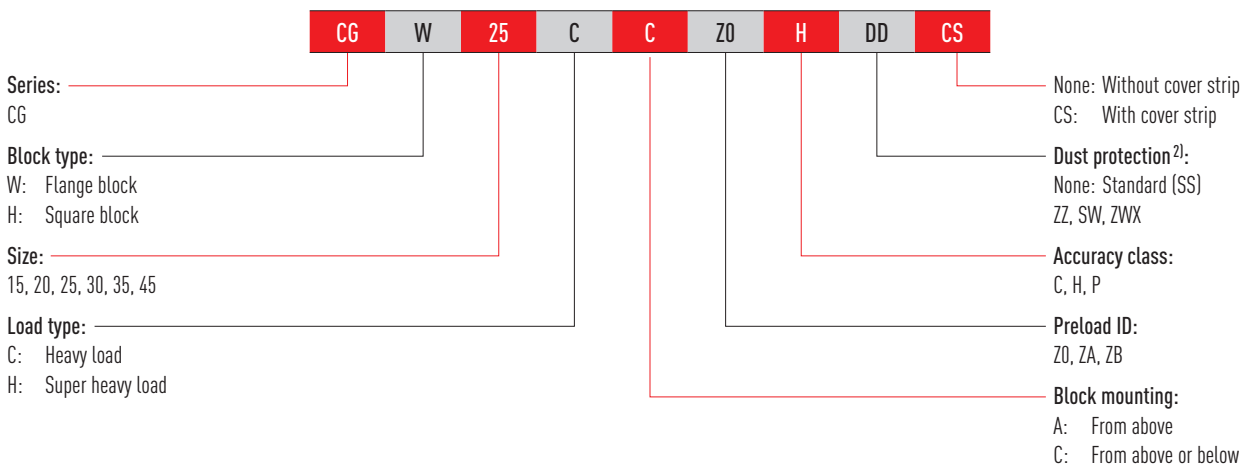

Order code for rail (unmounted)

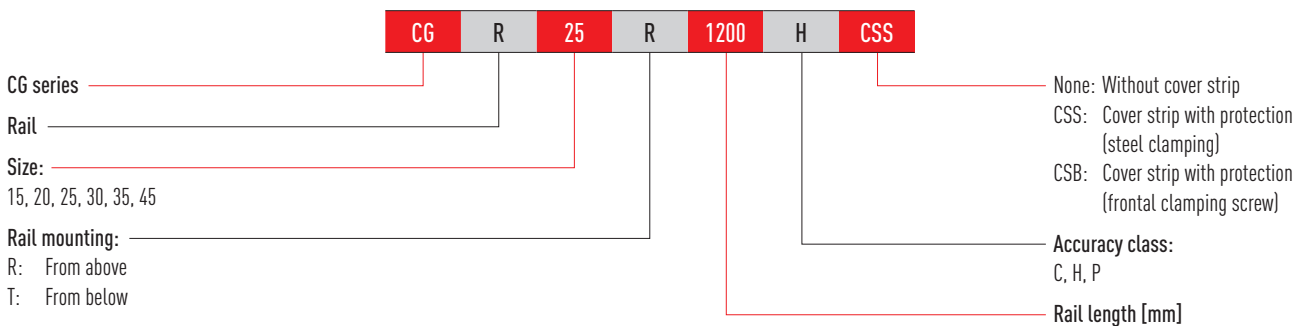

Note:

¹⁾ The figure 2 is also a quantity, i.e. one item of the above-mentioned article consists of a pair of rails. No number is specified for individual rails.

By default multi-part rails are delivered with staggered butt joints.

²⁾ You will find an overview of the individual sealing systems on [Page 22](#)

Linear guideways

CG series

3.3.4 Block types

HIWIN provides square and flange blocks for its linear guideways. Given their low height and larger mounting surface, flange blocks are better suited to large loads.

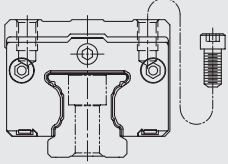
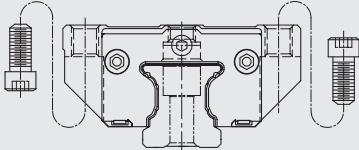
Type	Series/size	Structure	Height [mm]	Typical application
Square type	CGH-CA CGH-HA		28 – 70	<ul style="list-style-type: none"> ○ Woodworking ○ Machining centres ○ NC lathes ○ Grinding machines ○ Precision milling machines ○ High-performance cutting machines
Flange type	CGW-CA CGW-HA		24 – 60	<ul style="list-style-type: none"> ○ Automation technology ○ Transport technology ○ Measuring technology ○ Machines and equipment requiring high positioning accuracy

3.3.5 Rail types

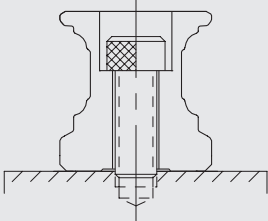
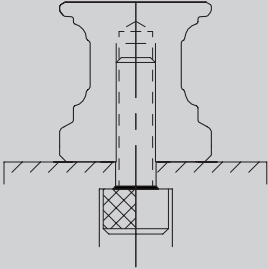
Fastening from above	Fastening from below
	
CGR_R	CGR_T

3.3.6 Preload

Definition

Every rail type can be preloaded based on the size of the balls. The curve shows that the rigidity doubles at higher preload. The CG series offers three standard preload classes for various applications and conditions.

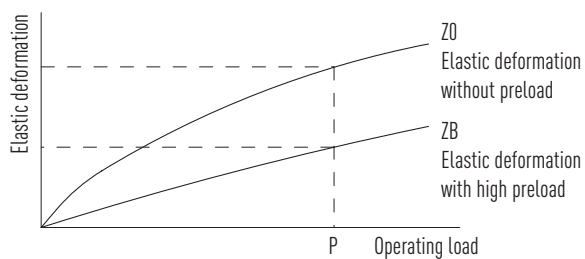

Preload ID

ID	Preload		Application	Sample applications
ZO	Light preload	0 – 0.02 C _{dyn}	Constant load direction, little vibration, lower accuracy needed	<ul style="list-style-type: none"> ○ Transport technology ○ Automatic packaging machines ○ X-Y axis in industrial machines ○ Welding machines
ZA	Medium preload	0.05 – 0.07 C _{dyn}	High accuracy needed	<ul style="list-style-type: none"> ○ Machining centres ○ Z axes for industrial machines ○ Eroding machines ○ NC lathes ○ Precision X-Y tables ○ Measuring technology
ZB	High preload	above 0.1 C _{dyn}	High rigidity needed, vibration and impact	<ul style="list-style-type: none"> ○ Machining centres ○ Grinding machines ○ NC lathes ○ Horizontal and vertical milling machines ○ Z axis of machine tools ○ High-performance cutting machines

3.3.7 Load ratings and torques

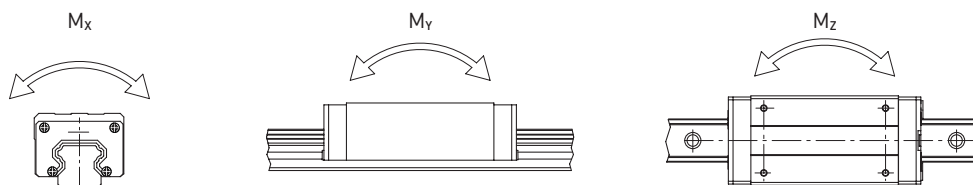

Series/size	Dynamic load rating C _{dyn} [N] ¹⁾	Static load rating C ₀ [N]	Dynamic moment [Nm]			Static moment [Nm]		
			M _x	M _y	M _z	M _{0x}	M _{0y}	M _{0z}
CG_15C	14,700	19,520	143	105	105	190	140	140
CG_20C	23,700	30,510	287	218	218	370	280	280
CG_20H	28,600	39,900	344	344	344	480	480	480
CG_25C	34,960	43,940	477	390	390	600	490	490
CG_25H	40,500	54,080	554	546	546	740	730	730
CG_30C	46,000	55,190	792	583	583	950	700	700
CG_30H	58,590	78,180	1,011	921	921	1,350	1,230	1,230
CG_35C	61,170	79,300	1,334	841	841	1,730	1,090	1,090
CG_35H	77,900	112,340	1,705	1,400	1,400	2,460	2,020	2,020
CG_45C	98,430	112,660	3,037	2,076	2,076	3,560	2,350	2,350
CG_45H	125,580	159,600	2,893	2,549	2,549	5,050	4,450	4,450

¹⁾ Dynamic load rating for travel distance of 50,000 m

Linear guideways

CG series

3.3.8 Rigidity

Rigidity depends on preload. Formula [F 3.7](#) can be used to determine deformation depending on rigidity.

F 3.7

$$\delta = \frac{P}{k}$$

δ Deformation [μm]
 P Operating load [N]
 k Rigidity [N/ μm]

Table 3.45 Radial rigidity for series CG

Load class	Series/ size	Rigidity depending on preload		
		Z0	ZA	ZB
Heavy load	CG_15C	240	290	330
	CG_20C	270	420	480
	CG_25C	340	440	570
	CG_30C	440	550	760
	CG_35C	470	610	800
	CG_45C	550	720	820
Super heavy load	CG_20H	360	470	530
	CG_25H	410	540	620
	CG_30H	490	640	730
	CG_35H	570	730	840
	CG_45H	740	960	1,100

Unit: N/ μm

3.3.9 Dimensions of the CG blocks

3.3.9.1 CGH

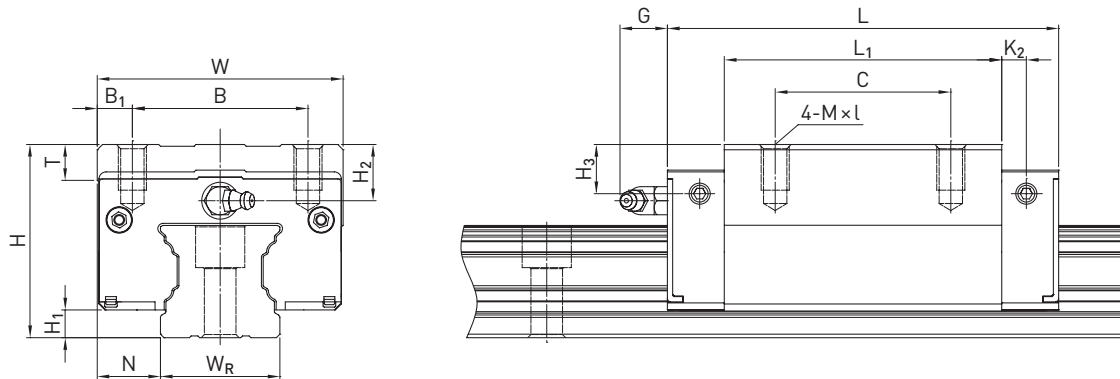

Table 3.46 Dimensions of the block

Series/size	Installation dimensions [mm]			Dimensions of the block [mm]													Load ratings [N]		Weight [kg]
	H	H ₁	N	W	B	B ₁	C	L ₁	L	K ₂	G	M × l	T	H ₂	H ₃	C _{dyn}	C ₀		
CGH15CA	28	4.1	9.5	34	26	4.0	26	39.6	58.2	4.25	6.0	M4 × 6	6.0	7.8	7.8	14,700	19,520	0.15	
CGH20CA	30	4.6	12.0	44	32	6.0	36	52.5	74.9	5.50	6.0	M5 × 6	8.0	3.7	3.5	23,700	30,510	0.25	
CGH20HA							50												68.5
CGH25CA	40	6.1	12.5	48	35	6.5	35	61.0	84.0	5.00	12.0	M6 × 8	8.0	10.0	9.5	34,960	43,940	0.46	
CGH25HA							50												78.4
CGH30CA	45	7.0	16.0	60	40	10.0	40	69.0	97.4	8.70	12.0	M8 × 10	9.5	9.7	10.0	46,000	55,190	0.71	
CGH30HA							60												91.5
CGH35CA	55	7.6	18.0	70	50	10.0	50	79.0	111.4	7.00	12.0	M8 × 13	10.2	16.0	14.0	61,170	79,300	1.24	
CGH35HA							72												103.4
CGH45CA	70	9.7	20.5	86	60	13.0	60	97.2	137.6	8.70	12.9	M10 × 17	16.0	18.5	18.2	98,430	112,660	2.38	
CGH45HA							80												133.6

For dimensions of rail, see [Page 69](#). for standard and optional lubrication adapter, see [Page 128](#).

Linear guideways

CG series

3.3.9.2 CGW

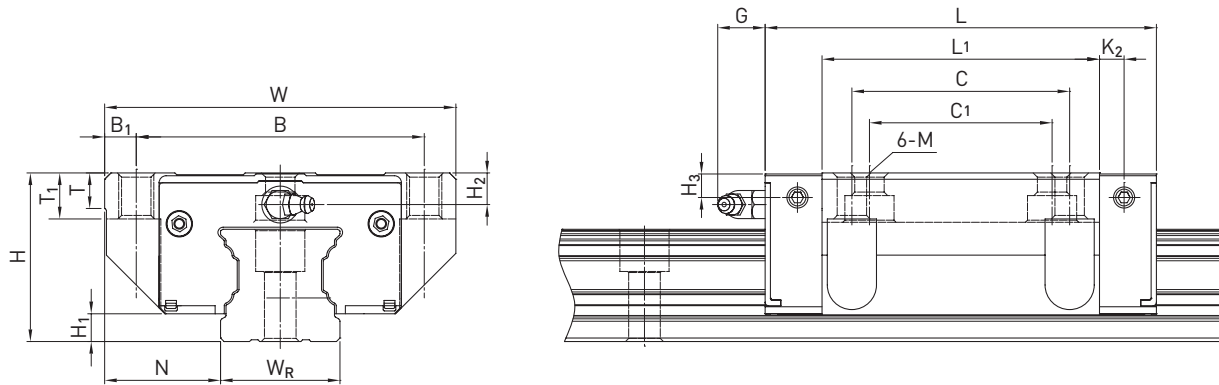

Table 3.47 Dimensions of the block

Series/size	Installation dimensions [mm]			Dimensions of the block [mm]															Load ratings [N]		Weight [kg]
	H	H ₁	N	W	B	B ₁	C	C ₁	L ₁	L	K ₂	G	M	T	T ₁	H ₂	H ₃	C _{dyn}	C ₀		
CGW15CC	24	4.1	16.0	47	38	4.5	30	26	39.6	58.2	4.25	6.0	M5	6.0	6.5	3.8	3.8	14,700	19,520	0.14	
CGW20CC	30	4.6	21.5	63	53	5.0	40	35	52.5	74.9	5.50	6.0	M6	6.5	7.7	3.7	3.5	23,700	30,510	0.36	
CGW20HC									68.5	90.9								28,600	39,900	0.47	
CGW25CC	36	6.1	23.5	70	57	6.5	45	40	61.0	84.0	5.00	12.0	M8	7.0	9.3	6.0	5.5	34,960	43,940	0.53	
CGW25HC									78.4	101.4								40,500	54,080	0.68	
CGW30CC	42	7.0	31.0	90	72	9.0	52	44	69.0	97.4	8.70	12.0	M10	10.5	12.0	6.7	7.0	46,000	55,190	0.90	
CGW30HC									91.5	119.9								58,590	78,180	1.19	
CGW35CC	48	7.6	33.0	100	82	9.0	62	52	79.0	111.4	7.00	12.0	M10	10.1	13.1	9.0	7.0	61,170	79,300	1.37	
CGW35HC									103.4	135.8								77,900	112,340	1.79	
CGW45CC	60	9.7	37.5	120	100	10.0	80	60	97.2	137.6	8.70	12.9	M12	15.1	15.0	8.5	8.1	98,430	112,660	2.45	
CGW45HC									133.6	174.0								125,580	159,600	3.00	

For dimensions of rail, see [Page 69](#). for standard and optional lubrication adapter, see [Page 128](#).

3.3.10 Dimensions of the CG rail

3.3.10.1 Dimensions of rail CGR_R

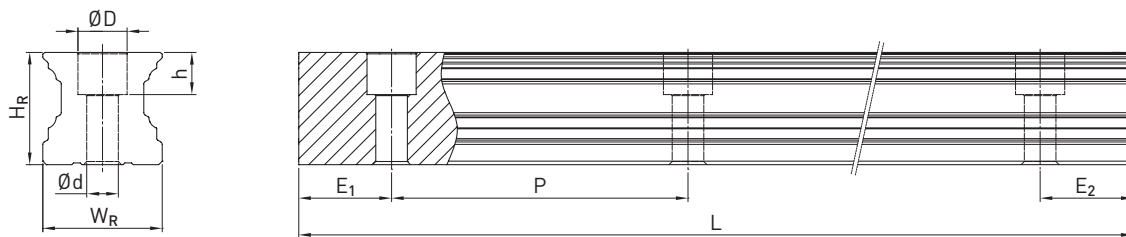

Table 3.48 Dimensions of rail CGR_R

Series/ size	Assembly screw for rail [mm]	Dimensions of rail [mm]						Max. length [mm]	Max. length E ₁ = E ₂ [mm]	Min. length [mm]	E _{1/2} min [mm]	E _{1/2} max [mm]	Weight [kg/m]
		W _R	H _R	D	h	d	P						
CGR15R	M4 × 20	15	16.20	7.5	5.9	4.5	60	4,000	3,900	132	6	54	1.58
CGR20R	M5 × 25	20	20.55	9.5	8.5	6.0	60	4,000	3,900	134	7	53	2.48
CGR25R	M6 × 30	23	24.25	11.0	9.0	7.0	60	4,000	3,900	136	8	52	3.38
CGR30R	M8 × 35	28	28.35	14.0	12.4	9.0	80	4,000	3,920	178	9	71	5.10
CGR35R	M8 × 40	34	31.85	14.0	12.0	9.0	80	4,000	3,920	178	9	71	7.14
CGR45R	M12 × 50	45	39.85	20.0	17.0	14.0	105	4,000	3,885	234	12	93	11.51

3.3.10.2 Dimensions of rail CGR_T

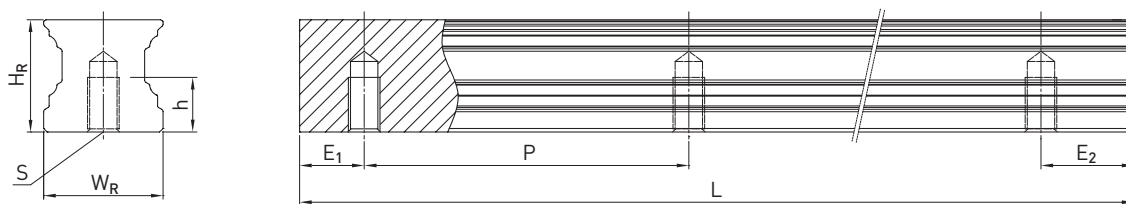

Table 3.49 Dimensions of rail CGR_T

Series/ size	Dimensions of rail [mm]					Max. length [mm]	Max. length E ₁ = E ₂ [mm]	Min. length [mm]	E _{1/2} min [mm]	E _{1/2} max [mm]	Weight [kg/m]
	W _R	H _R	S	h	P						
CGR15T	15	16.20	M5	8	60	4,000	3,900	132	6	54	1.58
CGR20T	20	20.55	M6	10	60	4,000	3,900	134	7	53	2.48
CGR25T	23	24.25	M6	12	60	4,000	3,900	136	8	52	3.38
CGR30T	28	28.35	M8	15	80	4,000	3,920	178	9	71	5.10
CGR35T	34	31.85	M8	17	80	4,000	3,920	178	9	71	7.14
CGR45T	45	39.85	M12	24	105	4,000	3,885	234	12	93	11.51

Note:

1. The tolerance for E is +0.5 to -1 mm for standard rails and 0 to -0.3 mm for joints.
2. If the E_{1/2} dimensions are not indicated, the maximum possible number of mounting holes will be determined under consideration of E_{1/2} min.
3. The rails are shortened to the required length. If the E_{1/2} dimensions are not indicated, these will be carried out symmetrically.

Linear guideways

CG series

3.3.10.3 Calculating the length of rails

HIWIN offers rails in customized lengths. To prevent the risk of the end of the rail becoming unstable, the value E must not exceed half of the distance between the mounting holes (P). At the same time, the value $E_{1/2}$ should be between $E_{1/2}$ min and $E_{1/2}$ max so that the mounting hole does not rupture.

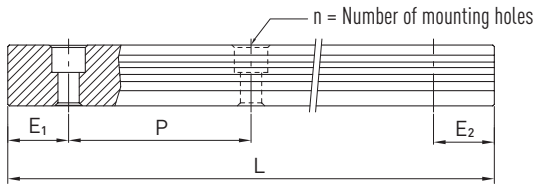

F 3.8

$$L = (n - 1) \times P + E_1 + E_2$$

- L Total length of the rail [mm]
- n Number of mounting holes
- P Distance between two mounting holes [mm]
- $E_{1/2}$ Distance from the middle of the last mounting hole to the end of the rail [mm]

3.3.10.4 Tightening torques for mounting bolts

Insufficient tightening of the mounting bolts strongly compromises the precision of the linear guideway; the following tightening torques are therefore recommended for the relevant screw sizes.

Table 3.50 Tightening torques of the mounting bolts according to ISO 4762-12.9

Series/size	Screw size	Torque [Nm]	Series/size	Screw size	Torque [Nm]
CG_15	M4 × 20	4	CG_30	M10	70
CG_20	M5 × 25	9	CG_35	M8 × 40	31
CG_25	M6 × 30	14	CG_35	M10	70
CG_30	M8 × 35	31	CG_45	M12 × 50	120

3.3.10.5 Cover caps for mounting holes of rails

The cover caps are used to keep the mounting holes free of chips and dirt. The standard plastic caps are provided with each rail. Optional cover caps must be ordered separately.



Table 3.51 Cover caps for mounting holes of rails

Rail	Screw	Article number			Ø D [mm]	Height H [mm]
		Plastic (200 pcs.)	Brass	Steel		
CGR15R	M4	5-002218	5-001344	—	7.5	1.2
CGR20R	M5	5-002220	5-001350	5-001352	9.5	2.5
CGR25R	M6	5-002221	5-001355	5-001357	11.0	2.8
CGR30R	M8	5-002222	5-001360	5-001362	14.0	3.5
CGR35R	M8	5-002222	5-001360	5-001362	14.0	3.5
CGR45R	M12	5-002223	5-001324	5-001327	20.0	4.0

3.3.10.6 Cover strip protection

The optional cover strip is delivered with a steel clamp for securing the strip. Alternatively, the cover strip can also be secured with a frontal clamping screw.



Fig. 3.1 Cover strip protection: steel clamp



Fig. 3.2 Cover strip protection: frontal clamping screw

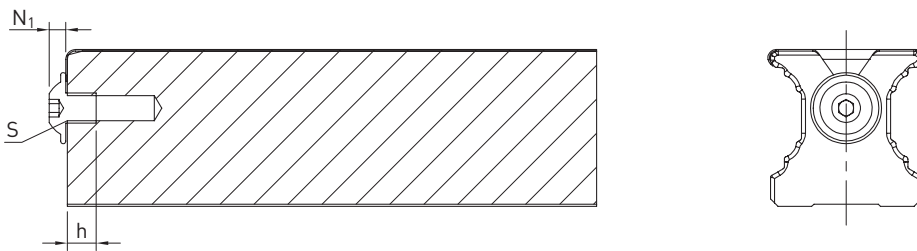

Table 3.52 Dimensions of frontal clamping screw protection

Series/size	S [mm]	h [mm]	N ₁ [mm]
CG_15	M3	5	1.65
CG_20	M4	5	2.20
CG_25	M4	5	2.20
CG_30	M4	5	2.20
CG_35	M6	9	3.30
CG_45	M6	9	3.30

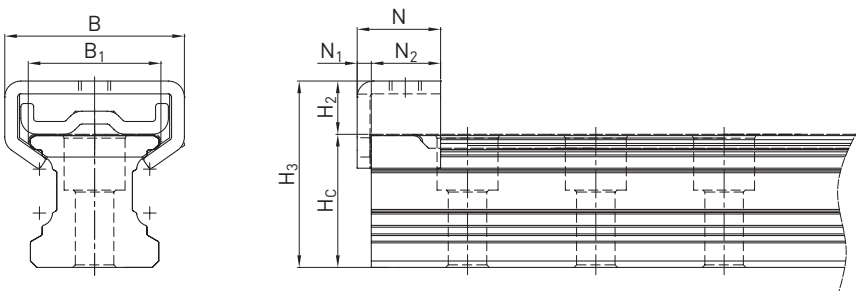

Table 3.53 Dimensions of steel clamp protection

Series/size	H ₃ [mm]	H _c [mm]	H ₂ [mm]	N	N ₁ [mm]	N ₂ [mm]	B [mm]	B ₁ [mm]
CG_15	20.09	16.70	3.9	15	2.2	12.8	21.0	15.8
CG_20	29.05	20.75	8.3	13	2.2	10.8	28.0	20.7
CG_25	34.42	24.45	10.0	15	2.2	12.8	30.6	23.9
CG_30	37.80	28.55	9.3	12	2.2	9.8	34.0	28.9
CG_35	43.20	30.40	13.0	18	2.2	15.8	35.4	34.8
CG_45	52.66	39.85	13.7	18	2.2	15.8	53.6	45.6

Linear guideways

CG series

3.3.11 Sealing systems

Various sealing systems are available for HIWIN blocks. You will find an overview on [Page 22](#). The table below shows the total length of the blocks with the different sealing systems. Sealing systems suitable for these sizes are available.

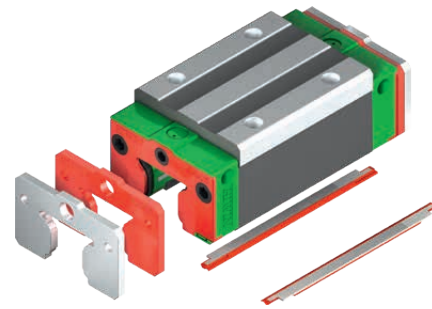

Table 3.54 Total length of blocks with different sealing systems

Series/ size	Total length L			
	SS	ZZ	SW	ZWX
CG15C	58.2	61.2	63.2	66.2
CG20C	74.9	77.9	79.9	82.9
CG20H	90.9	93.9	95.9	98.9
CG25C	84.0	90.0	89.0	95.0
CG25H	101.4	107.4	106.4	112.4
CG30C	97.4	103.4	102.8	108.8
CG30H	119.9	125.9	125.3	131.3
CG35C	111.4	117.4	116.8	122.8
CG35H	135.8	141.8	141.2	147.2
CG45C	137.6	143.6	143.0	149.0
CG45H	172.3	178.3	177.7	183.7

Unit: mm

3.3.12 Tolerances depending on accuracy class

The CG series is available in five accuracy classes depending on parallelism between block and rail, height accuracy H and accuracy of width N. The choice of accuracy class is determined by the machine requirements.

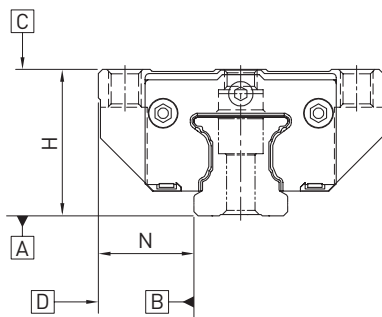

3.3.12.1 Parallelism

Parallelism of stop surfaces D and B of block and rail and parallelism of top of block C to mounting surface A of rail. Ideal linear guideway installation is required, as is a measurement in the centre of the block.

Table 3.55 Tolerance of parallelism between block and rail

Rail length [mm]	Accuracy class				
	C	H	P	SP	UP
- 100	12	7	3	2	2
100 - 200	14	9	4	2	2
200 - 300	15	10	5	3	2
300 - 500	17	12	6	3	2
500 - 700	20	13	7	4	2
700 - 900	22	15	8	5	3
900 - 1100	24	16	9	6	3
1100 - 1500	26	18	11	7	4
1500 - 1900	28	20	13	8	4
1900 - 2500	31	22	15	10	5
2500 - 3100	33	25	18	11	6
3100 - 3600	36	27	20	14	7
3600 - 4000	37	28	21	15	7

Unit: μm

Linear guideways

CG series

3.3.12.2 Accuracy – height and width

Height tolerance of H

Permissible absolute dimension variance of height H, measured between centre of screw-on surface C and underside of rail A, with block in any position on the rail.

Height variance of H

Permissible variance of height H between several blocks on a rail, measured in the same rail position.

Width tolerance of N

Permissible absolute dimension variance of width N, measured between centre of screw-on surfaces D and B, with block in any position on the rail.

Width variance of N

Permissible variance of width N between several blocks on a rail, measured in the same rail position.

Table 3.56 Height and width tolerances

Series/size	Accuracy class	Height tolerance of H (T_H)	Width tolerance of N	Height variance of H	Width variance of N
CG_15, 20	C (Normal)	± 0.1	± 0.1	0.02	0.02
	H (High)	± 0.03	± 0.03	0.01	0.01
	P (Precision)	$0/-0.03^{1)}$ $\pm 0.015^{2)}$	$0/-0.03^{1)}$ $\pm 0.015^{2)}$	0.006	0.006
	SP (Super precision)	$0/-0.015$	$0/-0.015$	0.004	0.004
	UP (Ultra precision)	$0/-0.008$	$0/-0.008$	0.003	0.003
CG_25, 30, 35	C (Normal)	± 0.1	± 0.1	0.02	0.03
	H (High)	± 0.04	± 0.04	0.015	0.015
	P (Precision)	$0/-0.04^{1)}$ $\pm 0.02^{2)}$	$0/-0.04^{1)}$ $\pm 0.02^{2)}$	0.007	0.007
	SP (Super precision)	$0/-0.02$	$0/-0.02$	0.005	0.005
	UP (Ultra precision)	$0/-0.01$	$0/-0.01$	0.003	0.003
CG_45	C (Normal)	± 0.1	± 0.1	0.03	0.03
	H (High)	± 0.05	± 0.05	0.015	0.02
	P (Precision)	$0/-0.05^{1)}$ $\pm 0.025^{2)}$	$0/-0.05^{1)}$ $\pm 0.025^{2)}$	0.007	0.01
	SP (Super precision)	$0/-0.03$	$0/-0.03$	0.005	0.007
	UP (Ultra precision)	$0/-0.02$	$0/-0.02$	0.003	0.005

Unit: mm

¹⁾ Fully assembled linear guideway

²⁾ Unmounted linear guideway

3.3.12.3 Permissible mounting surface tolerances

Once the requirements relating to the accuracy of the mounting surfaces are met, the good accuracy, rigidity and lifetime of the CG series linear guideways are achieved.

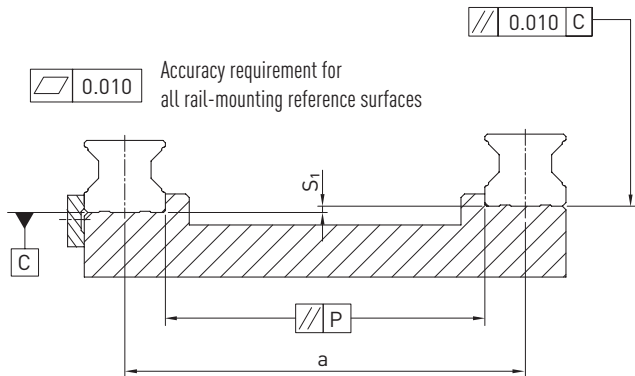

Tolerance for the parallelism of the reference surface (P):

Table 3.57 Maximum tolerance for parallelism (P)

Series/size	Preload class		
	Z0	ZA	ZB
CG_15	9	5	4
CG_20	11	7	5
CG_25	12	8	6
CG_30	14	9	7
CG_35	15	11	8
CG_45	19	12	10

Unit: μm

Tolerance for the height of the reference surface (S₁)

F 3.9 $S_1 = a \times K - T_H$

- S₁ Max. height tolerance [mm]
- a Distance between rails [mm]
- K Coefficient of the height tolerance
- T_H Tolerance of height H acc. to [Table 3.56](#)

Table 3.58 Coefficient of height tolerance (K)

Series/size	Preload class		
	Z0	ZA	ZB
CG_15 – CG_45	2.8×10^{-4}	1.7×10^{-4}	1.2×10^{-4}

Note: If $S_1 < 0$, select another tolerance class!

Linear guideways

CG series

Height tolerance of the block mounting surface:

- The height tolerance of the reference surface in the parallel use of two or more blocks (S_2)

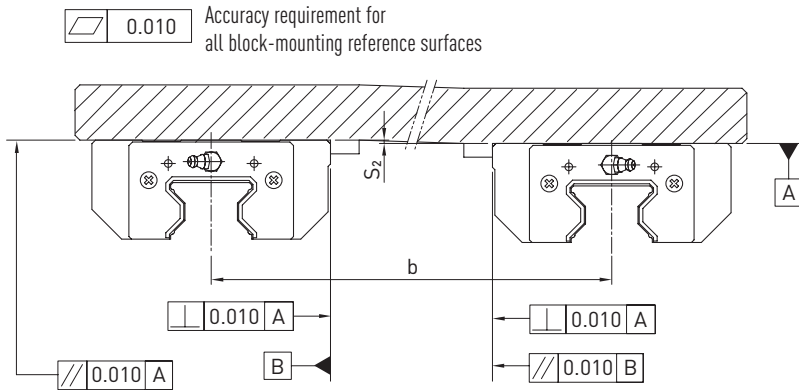

F 3.10 $S_2 = b \times K$

- S_2 Max. height tolerance [mm]
- b Distance between blocks [mm]
- K Coefficient of the height tolerance

- The height tolerance of the reference surface in the parallel use of two or more blocks (S_3)

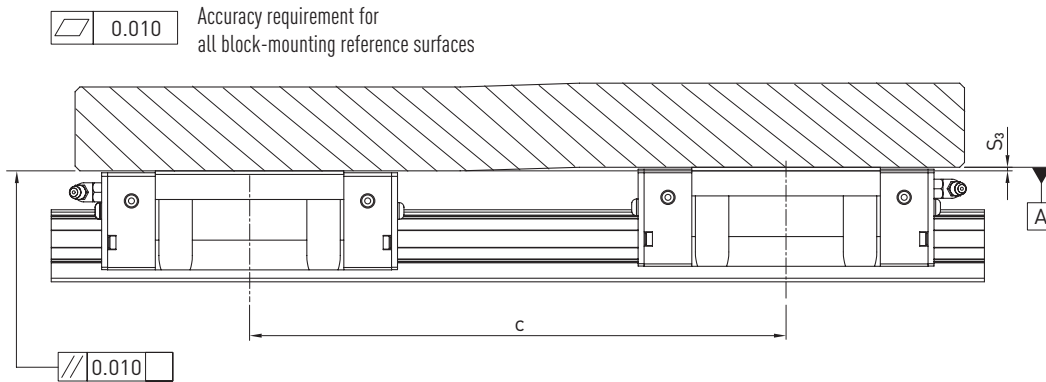

F 3.11 $S_3 = c \times K$

- S_3 Max. height tolerance [mm]
- c Distance between blocks [mm]
- K Coefficient of the height tolerance

Series/size	Load type	
	CG_C	CG_H
CG_15 - CG_45	4.2×10^{-5}	3.0×10^{-5}

3.3.13 Shoulder heights and fillets

Imprecise shoulder heights and fillets of mounting surfaces compromise precision and may lead to conflicts with the block or rail profiles. The following shoulder heights and edge profiles must be observed in order to avoid assembly problems.

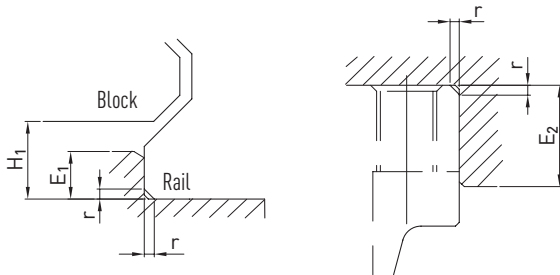

Table 3.60 Shoulder heights and fillets

Series/size	Max. edge radius r	Shoulder height of reference edge of rail E_1	Shoulder height of reference edge of block E_2	Clearance under block H_1
CG_15	0.5	3.0	4.0	4.3
CG_20	0.5	3.5	5.0	4.6
CG_25	1.0	5.0	5.0	6.1
CG_30	1.0	5.0	5.0	7.0
CG_35	1.0	6.0	6.0	7.6
CG_45	1.0	8.0	8.0	9.5

Unit: mm

Linear guideways

WE and QW series

3.4 WE and QW series

3.4.1 Properties of the linear guideway, series WE and QW

The HIWIN linear guideways of the WE series are based on proven HIWIN technology. Their large rail width and low installation height permit a compact design and high torque loading capacity.

The models of the QW series with SynchMotion™ technology offer all the advantages of the standard series WE. Controlled movement of the balls at a defined distance also results in improved synchronous performance, higher reliable travel speeds, extended lubrication intervals and less running noise. Since the installation dimensions of the QW blocks are identical to those of the WE blocks, they are also fitted on the WER standard rail and can therefore be interchanged with ease. For more information, refer to [Page 24](#).

3.4.2 Design of the WE/QW series

- 4-row recirculation ball bearing guide
- 45° contact angle
- Ball retainers prevent the balls from falling out when the block is removed
- Low installation height
- Wide linear guideway for high torque loading capacity
- Large mounting surface on block
- SynchMotion™ technology (QW series)

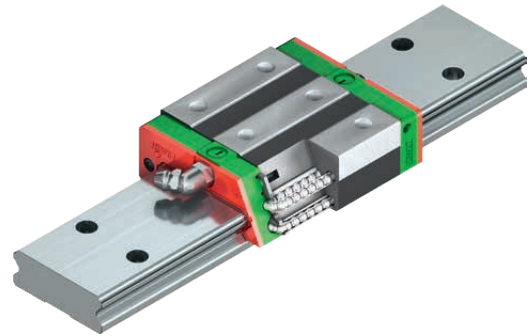
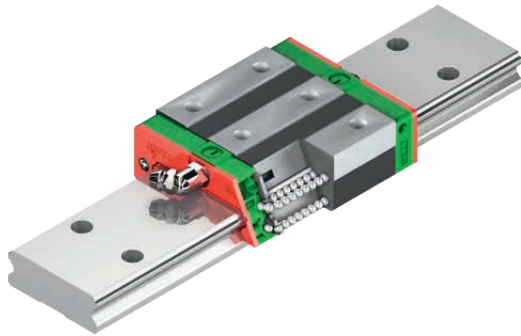

Design of the WE series

Advantages:

- Compact and low-cost design thanks to high torque loading capacity
- High efficiency thanks to low friction losses

Design of the QW series

Additional advantages of QW series:

- Improved synchronous performance
- Optimized for higher travel speeds
- Extended lubrication intervals
- Less running noise
- Higher dynamic load capacities

50% wider than standard series

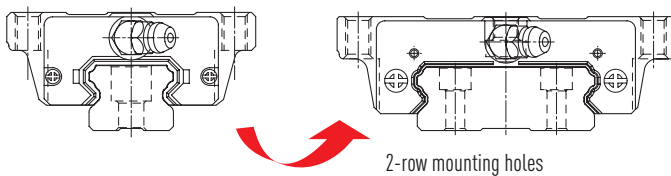

- The block's large mounting surface supports the transfer of higher torques
- The 45° arrangement of ball tracks permits high loading from all directions

