



Guide Elements

Guide Elements

The great importance of exact alignment between punches and matrices in stamping dies has been recognized widely. The accuracy and maintenance of this alignment depends entirely on the quality and wear resistance of the guide elements.

As a consequence of recent rapid developments in stamping techniques it has also been accepted that conventional bush-pillar sets of casehardened steel can no longer stand up to the demands of the modern press shop with its more sophisticated dies, ever faster presses and the stresses in today's carbide tools.

The introduction of FIBRO Guide Elements made available an extensive range, principally based on superlative quality, and comprising some new, highly advanced bearing materials as well as novel assembly techniques of superior accuracy.

Recent additions have further broadened this range, especially in regard of demountable guiding components.

All FIBRO Guide Bushes for permanent fixing are laid out for epoxy-bonding. This highly reliable method ensures unparalleled accuracy together with the elimination of shrink allowances and rectification honing.

Ball Bearing Guides principally excel in undemanding maintenance and through the complete absence of bearing play. Their easy movement on the bench makes them very popular with die makers. Highest stroking speeds present no problems. But common to all ball bearings there remains the characteristic weakness to shock loads, the danger of ball impingement. To some extent this can be compensated for by oversized pillar diameters and the use of four-pillar die sets.

The group of Sliding-Type Guides affords much greater stability, partly due to the damping effect of the all-important, vital oil film . . . which in the past used to be threatened always by the vagaries of lubrication service and the propensity to rupture at high frequencies of travel reversal.

Extensive protection against these perils is offered by FIBRO Sintered Ferrite Bushes. Used in most of our sliding guide systems, their advanced technology comprises:

- porous structure, vacuum-filled with oil
- carbonitrided surface of extreme hardness
- outstanding friction properties
- exceptional wear-resistance
- thousands of oil-retaining porosity pockets.

In combination with our mirror-finished pillars, ferrite guide bushes represent a guiding system of altogether superior properties. A system that virtually precludes seizing under all but the most extreme running conditions.















Beyond such limitations there exist combinations of high velocities with very short strokes where even ferrite bushes cannot guarantee permanence of the oil film.

Here, the rigidity of the sliding guide has to be weighed up against the safety of ball bearings: die set guides are not entirely without problems yet! But at FIBRO we find ourselves very busy indeed with the remainder.

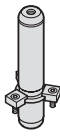



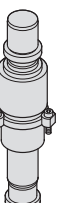





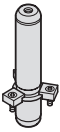
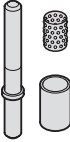
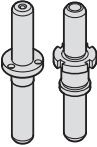

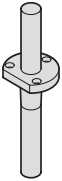
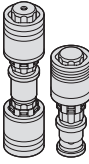









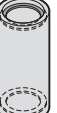

Technical progress may incur modifications without notice.

**FIBRO GUIDE ELEMENTS – DESIGNED
AND PRODUCED BY PEOPLE IN PURSUIT OF
PERFECTION.**











Contents

	Page		Page
Notes on Guide Elements	D9		2021.39. Liner Bushes, DIN 9825/ISO 9182-4, for conical pillars 2021.50. D24
Sliding Guide Systems: Clearance and Pairing Recommendations	D10-D11		210.39. Liner Bushes AFNOR, for conical pillars 2021.50. D25
Selection matrix Guide Pillars – Guide Bushes	D12		
 202.19. Guide Pillars, small dimensions	D14		2022.25. Guide Pillars ~AFNOR with Retaining Ring Groove D26
206.51. Ball Cages small dimensions	D15		
206.54. Guide Bushes, small dimensions			2022.12. Guide Pillars to Daimler with Pilot Taper, for Large Tools and Snap Ring Groove D27
	202.19. Guide Pillars DIN 9825/ISO 9182-2 D16		2022.15. Guide Pillars to VDI 3356, with Pilot Taper, for Large Tools D28
202.17. Guide Pillars with Ball Cage Retainer			2022.17. Guide Pillars to VW, with Groove, for Large Tools D29
202.22. Guide Pillars ~DIN 9825/ 202.23. ~ISO 9182 press-in type, with 202.24. internal threads	D17		2022.16. Guide Pillars to Daimler, for Large Tools with Snap Ring Groove D30
	202.21. Guide Pillars – endwise bolt-on type ~DIN 9825/~ISO 9182-2 D18		2022.19. Guide Pillars for Large Tools D31
202.55. Guide Pillars – endwise bolt on type with Ball Cage Retainer	D18		2022.13. Guide Pillars to VW, with 5° Pilot Taper D32
	202.29. Guide Pillars ECO-LINE ~DIN 9825/~ISO 9182-2 D19		2022.16.45. Guide Pillars to CNOMO, with Groove D33
	202.31. Guide Pillars ECO-LINE endwise bolt on type ~DIN 9825/~ISO 9182-2 D20		2022.29. Guide Pillars to WDX with Collar, with Screw Clamps D34
	2021.50. Demountable Pillars, conical, DIN 9825/ISO 9182-4 similar AFNOR* D22		2021.46. Demountable Pillars DIN 9825/~ISO 9182-5 with Collar and Screw Clamp Retention D35
2021.58. Demountable Pillars, conical, with Ball Cage Retainer			2021.44. Demountable Pillars, with Ball Cage Retainers
	202.53. Retaining disc with head cap screw, similar AFNOR D23		2021.43. Retaining Disc with Screw
	2021.53. Retaining disc with countersunk head screw, DIN 9825/ISO 9182-4		2025.94. Ball guide units, complete to Daimler standard D36

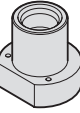
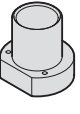
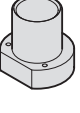
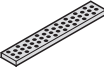
Contents

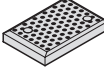
	Page		Page
	2021.29.	Guide Pillars with collar, ECO-LINE	D37
	206.41. 2062.44. 202.61. 2061.44.	Ball Guides for highest stroking speeds	D38
	2020.63. 2020.62. 202.60.	Stripper-Mounted Pillars	D39- D41
	2021.64.	Stripper-Mounted Retaining Bushes, conical pillar fit	D42
	2020.64.	Stripper-Mounted Guide Pillars, conical pillar fit	D43
	2024.94. 2024.96.	Guide units Million-Guide	D44- D47
	2031.70.	Rectangular Mounting Flanges Bronze with Non-Liquid Lubricant	D48
	2031.01. 2031.31. 2031.41.	Rectangular Mounting Flanges for Guide Pillars and Guide Bushes – without screw holes –	D49
	2031.02. 2031.34. 2031.42.	Rectangular Mounting Flanges for Guide Pillars and Guide Bushes – with screw holes –	D50
	2031.04. 2031.38. 2031.44.	Shallow Mounting Flanges, Rectangular, for Guide Pillars and Guide Bushes, – with screw holes –	D51
	2032.02. 2032.70.	Rectangular Mounting Flanges for Guide Pillars and Guide Bushes Bronze with Non-Liquid Lubricant	D52
	2051.32.	Sintered Ferrite Guide Bushes carbonitrided, for slip fit bonding DIN 9831/ISO 9448-2	D54
	Special Ball Bearing Cages – Brass		D55
	Tables: Safe Loads for FIBRO Ball Bearing Guides		D56- D57
	2061.44.	Guide Bushes for Ball Bearings, for slip fit bonding, DIN 9831/ISO 9448-3	D58
	206.49.	Guide Bushes for Ball Bearings, for slip fit bonding, similar AFNOR	D59
	206.71.	Ball Cages with securing ring groove	D60
	206.72.	Circlips	D61
	206.73.	Ball Cages with cage spacing	D62
	206.75.	Ball Cages with Circlip DIN 472 and Fastning Ring Groove	D63
	2061.47.	Guide Bushes for Ball Bearings with stroke Limitation for slip fit bonding	D63
	2081.67.	Headed Guide Bushes for Ball Bearings, with ball cage retainer	D64
	2091.67.	Flanged Guide Bushes for Ball Bearings, with ball cage retainer	D65
	2061.82.	Roller Cages with circlip groove	D66
	2061.84.	Roller Cages with mounting aid	D67- D69
	2081.81. 2081.84. 2081.85.	Headed Guide Bushes, to ISO 9448, Steel, with bronze-coated internal bore	D70- D74
	2081.31. 2081.32. 2081.33. 2081.34. 2081.35.	Headed Guide Bushes, sintered ferrite, carbonitrided, long-term lubrication, DIN 9831/ISO 9448-6	D70- D74







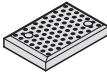
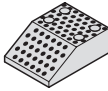
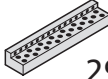
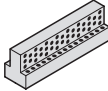
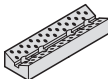
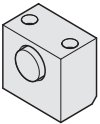





Contents

		Page		Page
	2081.91. Headed Guide Bushes, bronze plated, ECO-LINE 2081.94. 2081.95.	D75- D77		
	2081.71. Headed Guide Bushes, bronze with solid lubricant rings, ECO-LINE 2081.74. 2081.75.	D78- D80		Oilless Guide Elements D103- D228 D105
	2081.44. Headed Guide Bushes for Ball Bearings, DIN 9831/ISO 9448-7 2081.45. 2081.46. 2081.47. 2081.49.	D81- D85		D106- D117
	2091.31. Flanged Guide Bushes, sintered ferrite, carbonitrided, DIN 9831/ISO 9448-4 2091.32. 2091.34.	D86- D88	2053.70. Thrust Washers	
	2091.71. Flanged Guide Bushes, DIN 9831/ISO 9448-5 Bronze with solid lubrication rings, ECO-LINE 2091.72. 2091.74.	D89- D91	2052.70. Guide Bushes 2085.70. Guide Bushes with collar 2085.71. Guide Bushes with collar 2086.70. Guide Bushes with collar 2085.72. Guide Bushes with collar 2082.70.55. Guide Bushes with collar to VW 2082.70. Guide Bushes to DIN 9834/ISO 9448 2072.45. Screw clamps to DIN 9832 2082.71. Guide Bushes to NAAMS 2072.46. Screw Clamps 2086.71. Guide Bushes with collar to NAAMS 2072.47. Screws Clamps to NAAMS 2102.70. Guide Bushes CNOMO 2102.71. Guide Bushes CNOMO 2073.45. Securing Flanges 2072.48.45. Screw Clamps to CNOMO	
	2091.44. Flanged Guide Bushes, DIN 9831/ISO 9448-5 for Ball Bearings 2091.45. 2091.46.	D92- D94		D119- D121
	210.31. Headed Guide Bushes, carbonitrided, long-term lubrication, similar AFNOR 210.34. 210.35.	D95- D97		D122- D124
	210.44. Headed Guide Bushes for Ball Bearings similar AFNOR 210.46.	D98- D99	2961.74. Retaining Plates to VDI 3357 Bronze with Non-Liquid Lubricant 2961.79. Retaining Plates, Steel, VDI 3357 2961.81. Retaining Plates, Steel with Non-Liquid Lubricant, VDI 3357 2961.82. Retaining Plates, Steel with Non-Liquid Lubricant 2961.79.45. Retaining Plates, Steel, to CNOMO 2961.81.45. Retaining Plates, Bronze with Non-Liquid Lubricant, to CNOMO 2961.78. Retaining Plates, Bronze with Non-Liquid Lubricant 2961.75. Flat Guide Bars 2961.76. 2961.77.	
	210.45. Guide Bushes with Collar for Ball Bearings similar AFNOR, Slotted Nuts	D100		
	210.85. Guide Bushes with Collar, Bronze coated to AFNOR, Slotted Nuts	D101		D129- D131

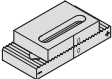
Contents

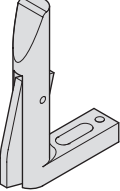
	Page		Page
 2960.72. Sliding Pads, small dimensions	D132- D157	 2960.90. Overrun Cams, Steel, to VDI 3357	D170
2960.71. Sliding Pads, Bronze, VDI 3357		2960.91. Overrun Cams, Steel, to VDI 3357	
2960.87. Sliding Pads, Steel, VDI 3357		2960.92. Overrun Cams, Bronze with Non-Liquid Lubricant, to VDI 3357	D171
2960.70. Sliding Pads, ISO 9183-1		 2962.70. Angled Guide Gibs, Bronze with Non-Liquid Lubricant	D172- D179
2960.85. Sliding Pads		2962.70.45. Angled Guide Gibs, Bronze with Non-Liquid Lubricant	
2960.86. Sliding Pads		2962.71. Angled Guide Gibs, Bronze with Non-Liquid Lubricant	
2960.76. Sliding Pads		2962.72. Angled Guide Gibs, Bronze with Non-Liquid Lubricant	
2962.78.45. Sliding Pads, Bronze with Non-Liquid Lubricant, to CNOMO		2962.73. Angled Guide Gibs, Bronze with Non-Liquid Lubricant	
2962.78. Sliding Pads		2962.81. Angled Guide Gibs, Bronze with Non-Liquid Lubricant	
2962.84.45. Sliding Pads, Steel, to CNOMO		2962.82. Angled Guide Gibs, Bronze with Non-Liquid Lubricant	
2962.85. Sliding Pads Steel with Non Liquid Lubricant		2962.83. Angled Guide Gibs, Bronze with Non-Liquid Lubricant	
2960.79. Sliding Pads to NAAMS, Bronze with Non-Liquid Lubricant		 2964.77. T-Guide Bars, Bronze with Non-Liquid Lubricant	D180
2960.80. Sliding Pads to NAAMS, Steel		2964.78. T-Guide Bars, Bronze with Non-Liquid Lubricant	
2960.74. Sliding Pads AFNOR, Bronze with Non-Liquid Lubricant		 2963.82. Sliding Blocks, Bronze with Non-Liquid Lubricant, NAAMS	D182- D193
2960.75. Sliding Pads AFNOR, Cast Iron with Non-Liquid Lubricant		2963.83. Prismatic Guides, Steel	
2960.44.45. Sliding Pads to CNOMO, Steel with oil lubricating groove		2963.84. Sliding Blocks, Bronze with Non-Liquid Lubricant, VDI 3357	
2960.54.45. Sliding Pads to CNOMO, Steel with oil lubricating groove		2963.85. Prismatic Guides, Steel	
2960.81. Sliding Pads, Bronze with Non-Liquid Lubricant, VDI 3357		2963.70. Prismatic Guides, Bronze with Non-Liquid Lubricant	
2960.88. Sliding Pads, Steel, VDI 3357		2963.71. Sliding Blocks, Steel	
2960.93. Sliding Pads, Bronze with Non-Liquid Lubricant, VDI 3357		2963.72. Prismatic Guides, Bronze with Non-Liquid Lubricant	
2962.75. Guide Bars with two Sliding Surfaces, VDI 3357	D158- D165	2963.73. Sliding Blocks, Steel	
2962.75.45. Guide Bars with two Sliding Surfaces, CNOMO		2963.81. Prismatic Guides, Steel	
2962.76. Guide Bars with three Sliding Surfaces		2963.80. Sliding Blocks, Bronze with Non-Liquid Lubricant	
2962.77. Guide Bars with two Sliding Surfaces		2965.81. Single-sided Prismatic Guides, Bronze	
2962.74. Guide Bars with four Sliding Surfaces		2965.83. Single-sided Prismatic Sliding Blocks, Steel	
2962.79. Guide Bars with one Sliding Surface		2965.80.45. Single-sided Prismatic Guides, Bronze	
2962.80. Guide Bars with three Sliding Surfaces		2965.82.45. Single-sided Prismatic Sliding Blocks, Steel, to CNOMO	
2960.73. Guide Brackets, Steel with Non-Liquid Lubricant, VDI 3387	D166	2965.80. Single-sided Prismatic Guides, Bronze	
2960.89. Guide Brackets, Bronze with Non-Liquid Lubricant, VDI 3387	D167	2965.82. Single-sided Prismatic Sliding Blocks, Steel	
2966.72. Slide centre guides, Bronze with Non-Liquid Lubricant	D168	 2451.6. Slide Stop	D194
		2451.6. .2 Stop buffer	
		Mounting Examples, Oilless Guide Elements	D196- D199

Contents

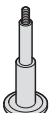
		Page			Page
	2441.11.0. Centering Units with Adjusting Washer	D200- D204		206.95. Pillar Wipers 2061.95.	D214
	2441.11. Centering Units without Adjusting Washer			244.00.2. Lifter Pins for Press Tool Strips	D215
	2441.11.3. Adjusting Washers			207.45 Screw Clamps 2072.45. 2072.46 2072.47 2071.45	D216- D217
	2441.13.45. Centering units to CNOMO			2073.45. Securing Flanges 2072.48.45. Screw Clamps, to CNOMO	D218
	2441.13.3.45. Adjusting Washers				
	2441.13. Centering Units to CNOMO				
	2441.13.3. Adjusting Washers				
	2445.10. Centering pins to VW standard 2445.11. Centering pins to Daimler standard	D206 D207		2444.12 Spacer Plates, toothed 2444.13	D219
	206.91. Concertina Shrouds 206.92.	D208- D209		2443.10. Guides 2443.12. Guides with Part Position Control and Spring 2443.13. Guides with Part Position Control to VDI	D220- D222
	206.93. Spacer Bushes			Assembly Guidelines for Guide Elements, Tolerances for Fitment	D224- D228
	206.94. Spacer Tubes				
	241.18. Helical Springs for Ball Cage Retention	D210			
	202.91. Cage Retainers 202.92.1. 202.93.	D211- D212			

FIBRO Precision Sliding Guides – Carbonitrided Sintered Ferrite Bushes

These guides employ bushes made from sintered ferrite of high purity with carbonitrided surface. Bearing surfaces are fine-ground.

The sintered ferrite has a porosity content of 18–20 % by volume, vacuum filled with special lubricant FIBROLIT LD. As additional long term lubrication it is recommended to fill up the groove in the bushing with FIBROLIT LD 280.34 – see page H 14. Even under arduous running conditions, this material can be relied upon for good protection against oil film rupture.

Under no circumstances must molybdenum disulfite be added to the lubricant.
For bearing clearance ranges – see page D 11.

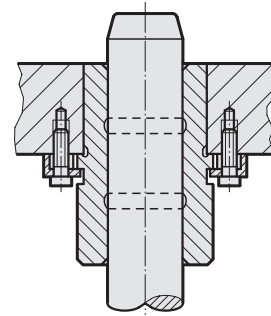

FIBRO Precision Sliding Guide, bronze-coated

consists of a steel body with bronze-coated running surface with helical oil groove and a grease nipple for lubrication.

The steel body guarantees excellent resistance to breaking, even when subject to high loading at the edges.

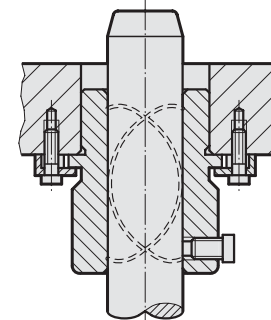

FIBRO Sliding Bearings with Non-Liquid Lubricant

The pockets containing the non-liquid lubricant occupy some 25 to 30 per cent of the bearing surface consisting of a bronze matrix.

After an initial oil lubrication on assembly, these elements are maintenance-free.

Wherever there is a demand for non-susceptibility against impact, contamination and heat, FIBRO Maintenance-Free Bearings find their ideal application.

We recommend to apply the tolerance classes H7/f6 to bush/pillar combinations using these elements.

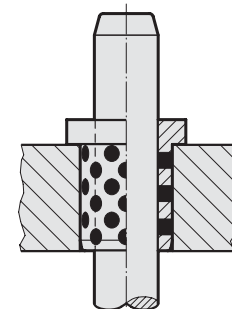

FIBRO Precision Ball Bearing Guides

Careful manufacture at narrowest tolerances, and exactly the right amount of preloading* result in a play-free guide element of exceptional performance potential. Our superfinished running surfaces further enhance the advantages of ball bearing guides. Toolmakers favour ball bearing guides because of their free movement on the bench. FIBRO ball bearing guides have brass ball cages – a material giving optimum results in stability and ball density.

Despite their unquestionable reliability at high speeds in particular, ball bearing guides with their point contact of the balls remain somewhat sensitive to shock and sustained radial loads.

To some extent, generous dimensioning of pillar diameters helps to compensate for this inherent disadvantage.

* Average preloading:

4 µm	on pillars from 8	to 12 mm diameter
7– 9 µm	on pillars from 15	to 16 mm diameter
9–11 µm	on pillars from 18	to 42 mm diameter
11–13 µm	on pillars from 50	to 80 mm diameter

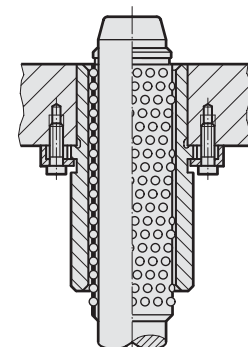

FIBRO Precision Roller Guides

In comparison to ball bearing guides, FIBRO Roller Guide Elements have considerably higher capacities for radial loads.

The much larger contact area of the rollers permits a significant reduction in preload values. This affords a longer service life of the units.

The following preload values apply to FIBRO Roller Guides:

For static loads/low velocities	or dynamic loads/high velocities
pillar diameters up to	pillar diameters up to
Ø 25 = 2,5 µm	Ø 25 = 1,5 µm
Ø 30/32 = 3 µm	Ø 30/32 = 2 µm
Ø 40–50 = 3,5 µm	Ø 40–50 = 2,5 µm
Ø 63 = 4 µm	Ø 63 = 3 µm

Use only pairing class
guide pillar red = .30
guide bush yellow = .10

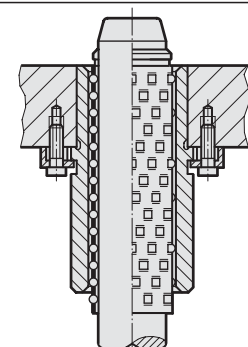

Pairing Classification

Guide Pillars with sliding sintered

Guide Pillars with Ball Bearing Bushes

Cutting clearance	Sliding guide bearing clearance	Ball bearing preloading		
small	small	large	Piece parts with small tolerances, closely specified cut edge properties and contours – also parts from thin material	Pairing 1
medium	medium	medium	Piece parts from sheet thicker than 1 mm – also preferably for progression dies	Pairing 2
large	large	small	Where demands on edges and burrs are not stringent; note that large die clearances require smaller shearing forces	Pairing 3

Selection of punch-matrix clearance is largely determined by piece part characteristics such as percentage of sheared land versus breakaway, but also by demands on burr formation. Further criteria are: properties of piece part materials, conditions of the tool as well as the condition of the eccentric press.

Colour coding by painted dots	Sliding guide				Ball bearing			
	Pillar		Bush		Pillar		Bush	
	Colour	Order No	Colour	Order No	Colour	Order No	Colour	Order No
Pairing 1	yellow	.10	yellow	.10	yellow	.10	red	.30
	green	.20	yellow	.10	yellow	.10	green	.20
					green	.20	red	.30
Pairing 2	green	.20	green	.20	yellow	.10	yellow	.10
	red	.30	yellow	.10	green	.20	green	.20
	yellow	.10	green	.20	red	.30	red	.30
Pairing 3	red	.30	red	.30	green	.20	yellow	.10
	green	.20	red	.30	red	.30	green	.20
	yellow	.10	red	.30	red	.30	yellow	.10

Selection Criteria:
die clearance – stock thickness – material

Note:

Please note that tight bearing clearances are normally unsuitable for 4-pillar die sets. In general, wherever retainer bore geometry is not absolutely perfect, pairings 2 and 3 must be chosen. The pairing classification does not signify differences in quality, rather a selection of the necessary bearing clearance in the case of guide pillars or preloading in the case of ball bearings (see also chart on page D 11).

Ordering Code (example):

Guide Pillar, tolerance range 1, yellow = 202.19.040.260.10 or green is then .20
Sliding guide, tolerance range 1, yellow = 2081.31.040.10

Pairing Classification

Guide Pillars with sliding sintered

Guide Pillars with Ball Bearing Bushes

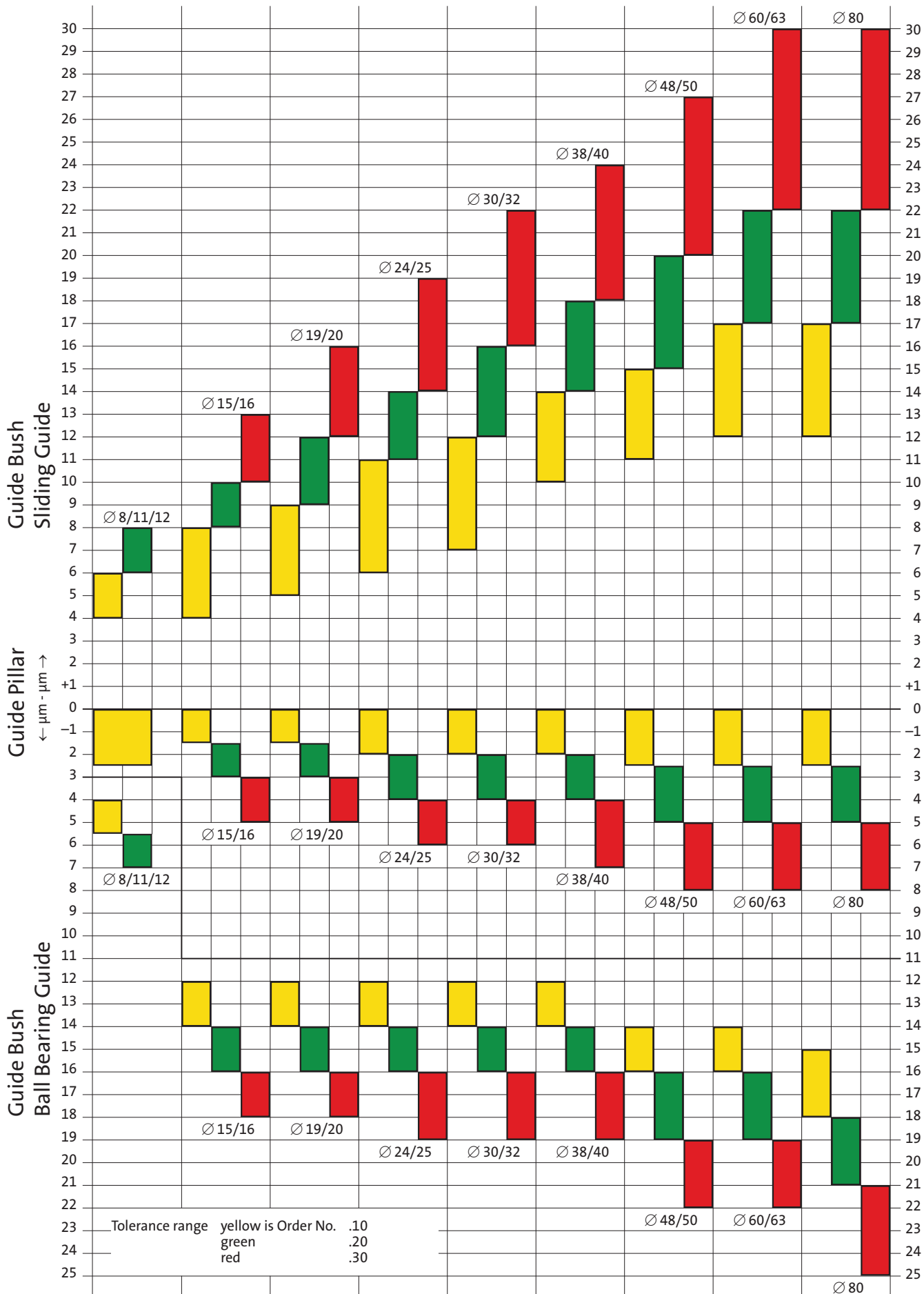

Selection matrix Guide Pillars - Guide Bushes

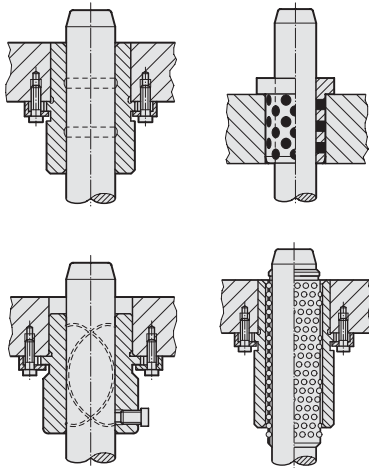

Guide Bushes			Guide Pillars															
			Tolerance range	202.17.	202.19.	202.21.	202.22.	202.23.	202.24.	2020.63.	2020.62.	2022.25.	2022.16.45.	2022.12.	2022.15.	2022.17.	2022.29.	202.31.
				.30	.20	.10	h3	.30	.20	.10	h5	-0.010 -0.025	f6	h4				
Ball bearing guide bushes	2061.44.	2081.44.	.10	● ¹	● ¹	● ¹	● ¹	● ¹	● ¹	● ¹	● ¹	● ¹	● ¹	● ¹	● ¹	● ¹	● ¹	● ¹
Mounting flanges with ball bearing guide bushes	206.49.	2081.45.		● ¹	● ¹	● ¹	● ¹	● ¹	● ¹	● ¹	● ¹	● ¹	● ¹	● ¹	● ¹	● ¹	● ¹	● ¹
	2081.47.	2081.46.		● ¹	● ¹	● ¹	● ¹	● ¹	● ¹	● ¹	● ¹	● ¹	● ¹	● ¹	● ¹	● ¹	● ¹	● ¹
	2081.67.	2081.47.	.20	● ¹	● ¹	● ¹	● ¹	● ¹	● ¹	● ¹	● ¹	● ¹	● ¹	● ¹	● ¹	● ¹	● ¹	● ¹
	2091.67.	2081.49.		● ¹	● ¹	● ¹	● ¹	● ¹	● ¹	● ¹	● ¹	● ¹	● ¹	● ¹	● ¹	● ¹	● ¹	● ¹
	2091.44.	210.44.		● ¹	● ¹	● ¹	● ¹	● ¹	● ¹	● ¹	● ¹	● ¹	● ¹	● ¹	● ¹	● ¹	● ¹	● ¹
	2091.45.	210.45.	.30	● ¹	● ¹	● ¹	● ¹	● ¹	● ¹	● ¹	● ¹	● ¹	● ¹	● ¹	● ¹	● ¹	● ¹	● ¹
	2091.46.	210.46.		● ¹	● ¹	● ¹	● ¹	● ¹	● ¹	● ¹	● ¹	● ¹	● ¹	● ¹	● ¹	● ¹	● ¹	● ¹
	2031.41.	2031.42.		● ¹	● ¹	● ¹	● ¹	● ¹	● ¹	● ¹	● ¹	● ¹	● ¹	● ¹	● ¹	● ¹	● ¹	● ¹
Guide bushes, sintered ferrite	2031.31.	2081.31.	.10	● ¹	● ¹	● ¹	● ¹	● ¹	● ¹	● ¹	● ¹	● ¹	● ¹	● ¹	● ¹	● ¹	● ¹	● ¹
Mounting flanges with guide bushes, sintered ferrite	2031.34.	2081.32.		● ¹	● ¹	● ¹	● ¹	● ¹	● ¹	● ¹	● ¹	● ¹	● ¹	● ¹	● ¹	● ¹	● ¹	● ¹
	2031.38.	2081.33.		● ¹	● ¹	● ¹	● ¹	● ¹	● ¹	● ¹	● ¹	● ¹	● ¹	● ¹	● ¹	● ¹	● ¹	● ¹
	2051.32.	2081.34.	.20	● ¹	● ¹	● ¹	● ¹	● ¹	● ¹	● ¹	● ¹	● ¹	● ¹	● ¹	● ¹	● ¹	● ¹	● ¹
	2091.31.	2081.35.		● ¹	● ¹	● ¹	● ¹	● ¹	● ¹	● ¹	● ¹	● ¹	● ¹	● ¹	● ¹	● ¹	● ¹	● ¹
	2091.32.	210.31.		● ¹	● ¹	● ¹	● ¹	● ¹	● ¹	● ¹	● ¹	● ¹	● ¹	● ¹	● ¹	● ¹	● ¹	● ¹
	2091.34.	210.34.	.30	● ¹	● ¹	● ¹	● ¹	● ¹	● ¹	● ¹	● ¹	● ¹	● ¹	● ¹	● ¹	● ¹	● ¹	● ¹
	210.35.	210.35.		● ¹	● ¹	● ¹	● ¹	● ¹	● ¹	● ¹	● ¹	● ¹	● ¹	● ¹	● ¹	● ¹	● ¹	● ¹
	2081.71.	2091.71.		● ¹	● ¹	● ¹	● ¹	● ¹	● ¹	● ¹	● ¹	● ¹	● ¹	● ¹	● ¹	● ¹	● ¹	● ¹
Guide bushes ECO-LINE bronze with solid lubrication rings	2081.74.	2091.72.	H6	●	○	○	○	○	○	○	○	○	○	○	○	○	○	○
	2081.75.	2091.74.		●	○	○	○	○	○	○	○	○	○	○	○	○	○	○
Guide bushes bronze coated	2081.81.	210.85.	IT5	●	●	○	○	○	○	○	○	○	○	○	○	○	○	○
	2081.84.			●	●	○	○	○	○	○	○	○	○	○	○	○	○	○
	2081.85.			●	●	○	○	○	○	○	○	○	○	○	○	○	○	○
Guide bushes ECO-LINE bronzeplated	2081.91.	2081.94.	H5	●	○	○	○	○	○	○	○	○	○	○	○	○	○	○
	2081.95.			●	○	○	○	○	○	○	○	○	○	○	○	○	○	○
Guide bushes with solid lubrication	2085.70.	2031.70.	H7	●	○	○	○	○	○	○	○	○	○	○	○	○	○	○
Mounting flanges with Guide bushes with solid lubrication	2085.72.	2087.71.		●	○	○	○	○	○	○	○	○	○	○	○	○	○	○
	2087.70.	2087.73.		●	○	○	○	○	○	○	○	○	○	○	○	○	○	○
	2087.72.	2082.71.		●	○	○	○	○	○	○	○	○	○	○	○	○	○	○
	2082.70.			●	○	○	○	○	○	○	○	○	○	○	○	○	○	○
Guide bushes with solid lubrication	2085.71.		E7	●	●	●	●	●	●	●	●	●	●	●	●	●	●	●
Guide bushes with solid lubrication	2086.70.	2032.70.	F7	●	●	○	○	○	○	○	○	○	○	○	○	○	○	○
	2052.70.			●	●	○	○	○	○	○	○	○	○	○	○	○	○	○
Guide bushes with solid lubrication	2102.70.	2102.71.	G7	●	●	○	○	○	○	○	○	○	○	○	○	○	○	○
Guide bushes with solid lubrication	2086.71.		C9	●	●	●	●	●	●	●	●	●	●	●	●	●	●	●

- = suitable
- ¹ = suitable (see page D10/D11)
- = conditionally suitable
- × = not suitable

The combinations should be considered as recommendations. Depending on the installation situation and type of use, a previous examination or test is mandatory, since different combinations may result in varying clearance (slide guide) or pretension (ball guides) values.

A large, empty rectangular box with rounded corners, occupying most of the page. It is intended for drawing or writing.

Guide Pillars,
small dimensions

202.19.

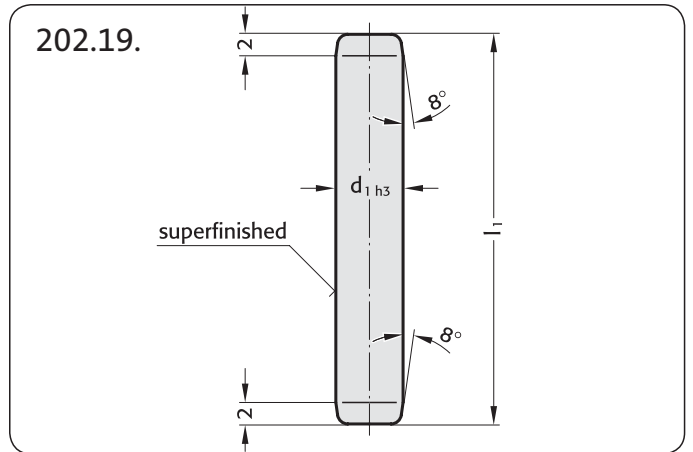
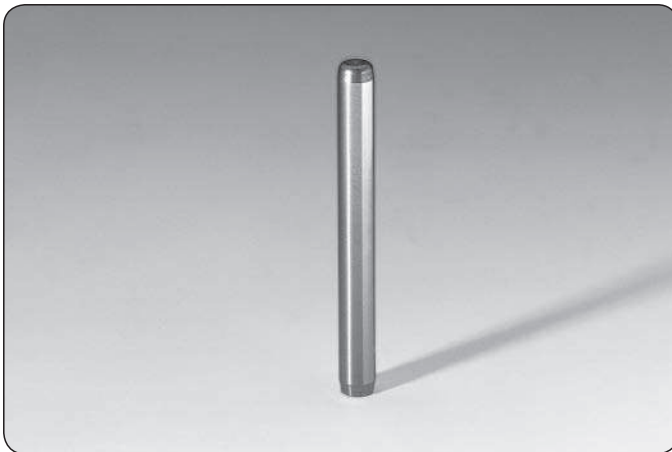

Material: alloy tool steel
Hardness: hardened to 60 + 4 HRC
Remarks: or from stainless steel on request
Hardness: hardened to 56 + 2 HRC
Execution: fine-ground and superfinished

Ordering Code (example):
 Guide Pillar = 202.19.
 d₁ = 4 mm = 004.
 l₁ = 80 mm = 080
 Order No = 202.19.004.080

202.19.

d ₁	3	4	5	6	8
30	●				
40		●	●	●	
50	●	●	●	●	●
60	●	●	●	●	●
80	●	●	●	●	●
100		●	●	●	●
125				●	●
140				●	●
160				●	●

FIBRO

206.51.
206.54

Ball Cages, small dimensions Guide Bushes, small dimensions

206.51.

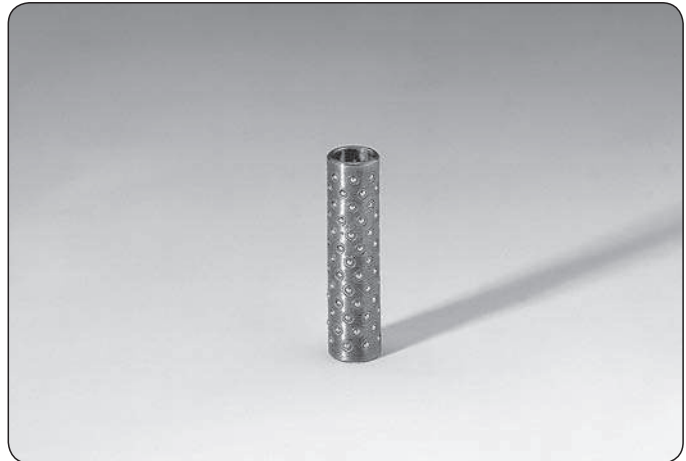
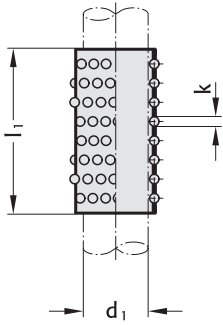

206.51.

d_1	3	4	5	6	8
k	1	1	1	1	1
l_1	total number of balls				
10	21	21	29	36	
15	35	35	49	61	61
20	49	49	69	69	69
25		64	89	89	89
30			109	109	109
40					149

Material:

Cage: Brass
Balls: hardened steel (DIN 5401)

Ordering Code (example):

Ball cage = 206.51.
 $d_1 = 3$ mm = 003.
 $l_1 = 15$ mm = 015
 Order No = 206.51.003.015

206.54.

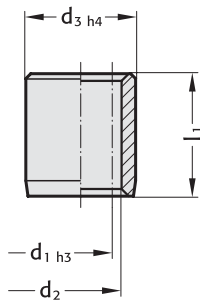

206.54.

d_1	3	4	5	6	8
d_2	5	6	7	8	10
d_3	7	8	10	11	14
l_1					
10	●	●	●		
15	●	●	●	●	●
20	●	●	●	●	●
25		●	●	●	●
30			●	●	●
35				●	●
40					●

Material:

Roller bearing steel 100 Cr 6
 Hardness: hardened to 60 + 4 HRC
 Remarks: available in stainless steel on request

Execution:

Guide Bush bores d_2
 fine-honed to IT3

Ordering Code (example):

Guide Bush = 206.54.
 $d_1 = 3$ mm = 003.
 $l_1 = 20$ mm = 020
 Order No = 206.54.003.020

**Guide Pillars
DIN 9825/ISO 9182-2**

**202.17.
202.19.**



202.17.
Guide Pillars (∅ 38–63) with Ball Cage Retainer
Dimensions of ball cage retainer: see page D211.



Mounting Examples

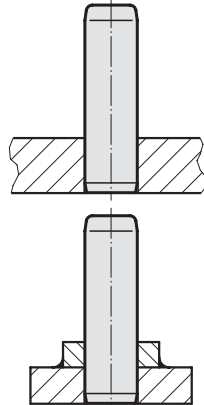

202.19.

202.17.
with Ball Cage Retainer

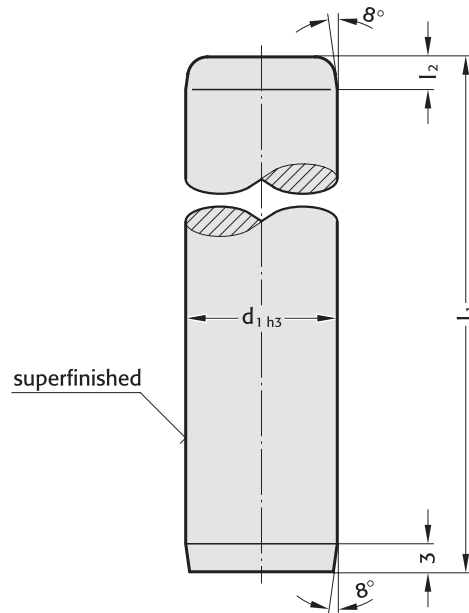

Material: Steel, surface hardened
Core strength: $\geq 900 \text{ N/mm}^2$
Surface Hardness: $60 + 3 \text{ HRC}$ (induction hardened)
Hardness Penetration: $\geq 1,8 \text{ mm}$ (diameter up to 12 mm: throughhardened)

Execution: precision ground, superfinished
Remarks: method of manufacturing entails that centre holes are not concentric with O.D.

202.19.

d_1	10	11	12	15	16	19	20	24	25	30	32	38	40	48	50	60	63	80																			
l_2	3	3	3	4	4	4	4	6	6	6	6	6	6	8	8	8	8	8																			
l_1	$d_1 < 10$ see page D 12																																				
80																																					
90																				●	●	●	●	●	●	●	●	●	●	●	●	●	●	●	●	●	●
100																				●	●	●	●	●	●	●	●	●	●	●	●	●	●	●	●	●	●
112																				●	●	●	●	●	●	●	●	●	●	●	●	●	●	●	●	●	●
125																				●	●	●	●	●	●	●	●	●	●	●	●	●	●	●	●	●	●
140																				●	●	●	●	●	●	●	●	●	●	●	●	●	●	●	●	●	●
160																					●	●	●	●	●	●	●	●	●	●	●	●	●	●	●	●	●
180																				Diameter 10–12 only available in Tolerance range yellow = .10			●	●	●	●	●	●	●	●	●	●	●	●	●	●	●
200																							●	●	●	●	●	●	●	●	●	●	●	●	●	●	●
224																							●	●	●	●	●	●	●	●	●	●	●	●	●	●	●
250																							●	●	●	●	●	●	●	●	●	●	●	●	●	●	●
280																							●	●	●	●	●	●	●	●	●	●	●	●	●	●	●
315																							●	●	●	●	●	●	●	●	●	●	●	●	●	●	●
355																							●	●	●	●	●	●	●	●	●	●	●	●	●	●	●
400																									●	●	●	●	●	●	●	●	●	●	●	●	●
450																										●	●	●	●	●	●	●	●	●	●	●	●
500																										●	●	●	●	●	●	●	●	●	●	●	●
550																											●	●	●	●	●	●	●	●	●	●	●
600																												●	●	●	●	●	●	●	●	●	●
700										●	●	●	●	●	●	●	●	●																			
800											●	●	●	●	●	●	●	●																			

Note:

Colour Code Combinations/Clearances – see pages D 10 and D 11.

Ordering Code (example):

Guide Pillar	= 202.19.	Tolerance range	yellow = .10
$d_1 = 40 \text{ mm}$	= 040.		green = .20
$l_1 = 200 \text{ mm}$	= 200.		red = .30
Tolerance range – yellow	= 10		
Order No	= 202.19.040.200.10		

Ordering Code (example):

Guide Pillar with Cage retainer	= 202.17.
$d_1 = 40 \text{ mm}$	= 040.
$l_1 = 200 \text{ mm}$	= 200.
Cage holder size 3	= 3.
Tolerance range – yellow	= 10
Order No	= 202.17.040.200.3.10

FIBRO

202.22. 202.23.
202.24.

Guide Pillars ~DIN 9825/~ISO 9182-2 with internal threads

202.22./202.23./202.24.

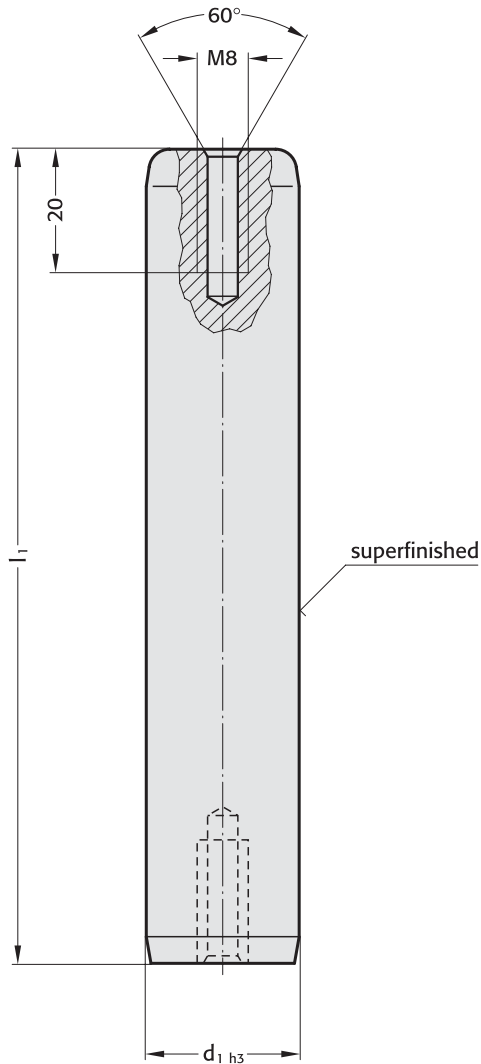

202.22.



202.23.



202.24.



Material: Steel, surface hardened
Core strength: $\cong 900 \text{ N/mm}^2$
Surface Hardness: 60 + 3 HRC (induction hardened)
Hardness Penetration: $\cong 1,8 \text{ mm}$

Execution: precision ground, superfinished

Note: Dimensions of pillar sizes from $d_1 = 15 \text{ mm}$ see catalogue page D16.
 Threads identical between the three pillar types.
 Colour Code Combinations/Clearances – see pages D10 and D11.

Tolerance range – yellow = .10
 green = .20
 red = .30

Ordering Code (example):

Pillar, threaded holes/both ends	=	202.22.
$d_1 = 30 \text{ mm}$	=	030.
$l_1 = 200 \text{ mm}$	=	200.
Tolerance range – green	=	20
Order No	=	202.22.030.200.20

Guide Pillars Endwise Bolt-On Type ~DIN 9825/~ISO 9182-2 with ball cage retainer

FIBRO

202.21.
202.55.

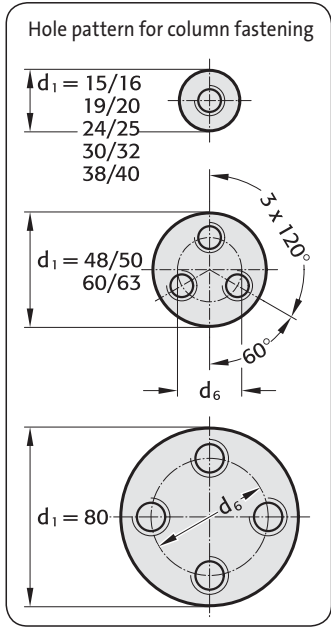

202.21.

Guide Pillars for endwise screw retention, complete with cap screws and washers.
Dimensions on page D16

202.55.

Guide Pillars (Ø 38–63) with Ball Cage Retainer.
Dimensions on page D211

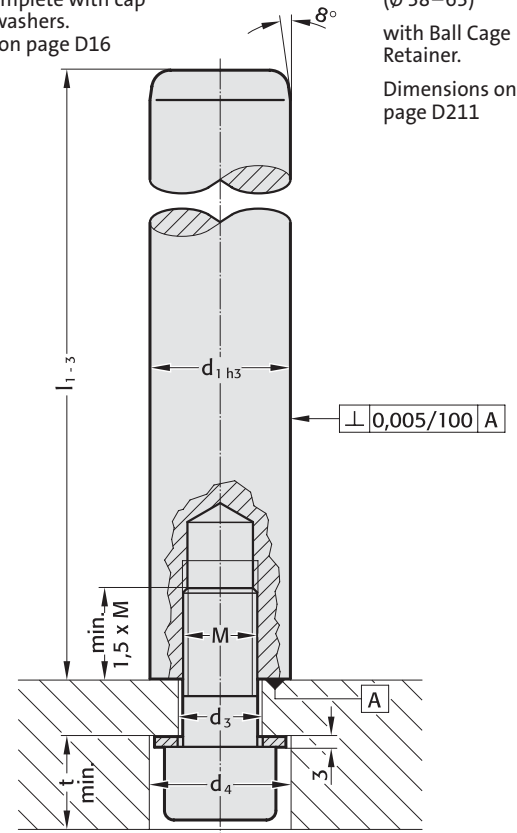

202.21./202.55. Dimensions on page D16

	15 16		19 20		24 25		30 32		38 40		48 50		60 63		80	
d ₁	15	16	19	20	24	25	30	32	38	40	48	50	60	63	80	80
d ₃	9	11	14	14	18	18	18	18	18	18	18	18	18	18	18	18
d ₄	17	20	22	22	28	28	28	28	28	28	28	28	28	28	28	28
d ₆	–	–	–	–	–	–	–	–	28	28	34	34	34	34	54	54
t	12	14	16	16	20,5	20,5	20,5	20,5	20,5	20,5	16	16	20,5	20,5	20,5	20,5
M	8	10	12	12	16	16	16	16	16	16	12	12	16	16	16	16
cap screw	M8x35	M10x40	M12x40	M12x40	M16x40	M16x40	3xM12x50	3xM12x50	3xM16x60	3xM16x60	4xM16x60	4xM16x60	4xM16x60	4xM16x60	4xM16x60	4xM16x60
Nm*	21	37	85	85	150	150	150	150	85	85	200	200	200	200	200	200

*tightening torque

Note:

Colour Code Combinations/Clearances – see pages d 10 and d 11.

Tolerance range – yellow = .10
green = .20
red = .30

Ordering Code (example):

Guide Pillar similar DIN 9825 = 202.21.

d₁ = 40 mm = 040.

l₁ = 200 mm = 200.

Tolerance range – red = 30

Order No = 202.21.040.200.30

Material:

Steel, surface hardened

Core strength:

≧ 900 N/mm²

Surface Hardness:

60+3 HRC (induction hardened)

Hardness Penetration:

≧ 1,8 mm

Execution:

fine precision ground
End face square within
0,005 mm in 100 mm

Remarks:

Method of manufacturing entails that
centre holes are not concentric with O. D.

The practical application of these pillars demands a certain amount of re-thinking in regard of tool design. Deflection under radially imposed load is shown in the diagram to the right.

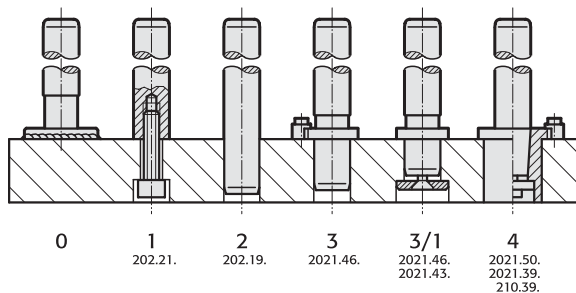

Mounting Instructions:

Coat head and threads of screws with molybdenum disulfite.
Tighten and undo screw twice before final tightening with torque wrench. Tightening torque is shown in the table above.

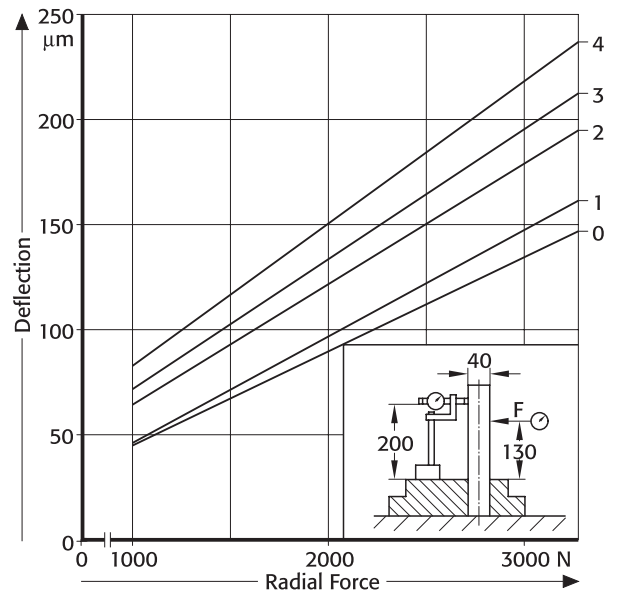

202.29.

202.29.

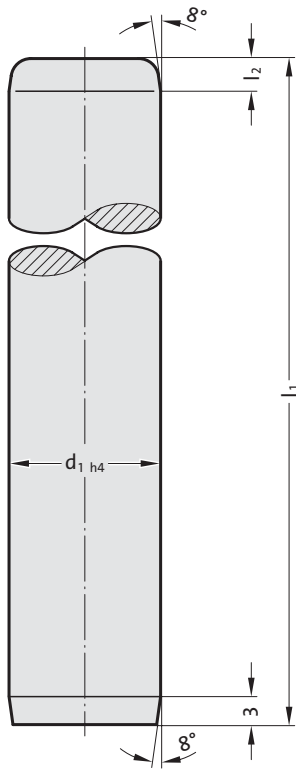

Material:

Steel, surface hardened
 Surface Hardness:
 60 + 4 HRC (induction hardened)
 Hardness Penetration:
 1,5+1 mm

Note:

Guide Pillars only recommended for use with sliding guides.

Mounting Examples

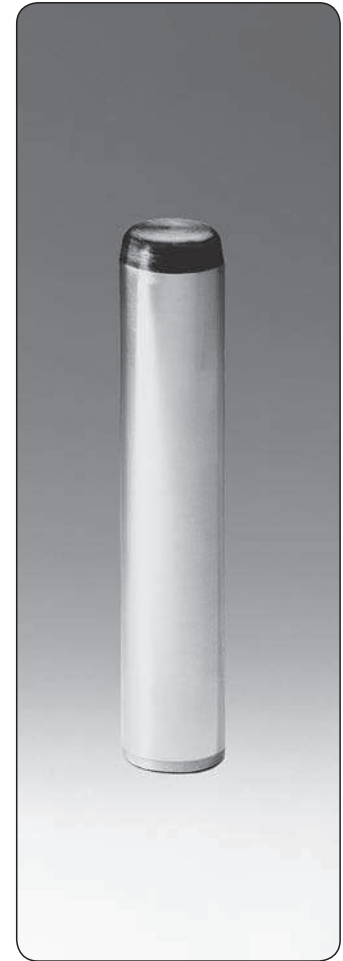
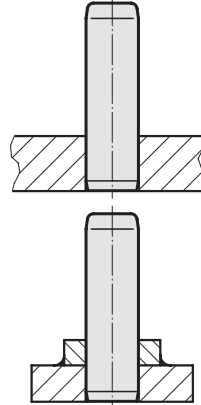

202.29.

d ₁	15 16	19 20	24 25	30 32	38 40	48 50	60 63	80
l ₂	4	4	6	6	6	8	8	8
l ₁								
90	●							
100	●							
112	●	●	●					
125	●	●	●	●				
140	●	●	●	●				
160	●	●	●	●	●			
180	●	●	●	●	●	●		
200	●	●	●	●	●	●		
224	●	●	●	●	●	●		
250	●	●	●	●	●	●	●	
280	●	●	●	●	●	●	●	●
315	●	●	●	●	●	●	●	●
355	●	●	●	●	●	●	●	●
400		●	●	●	●	●	●	●
450			●	●	●	●	●	●
500			●	●	●	●	●	●
550				●	●	●	●	●
600				●	●	●	●	●
700				●	●	●	●	●
800				●	●	●	●	●

Ordering Code (example):

Guide Pillar = 202.29.
 d₁ = 32 mm = 032.
 l₁ = 180 mm = 180
 Order No = 202.29.032.180

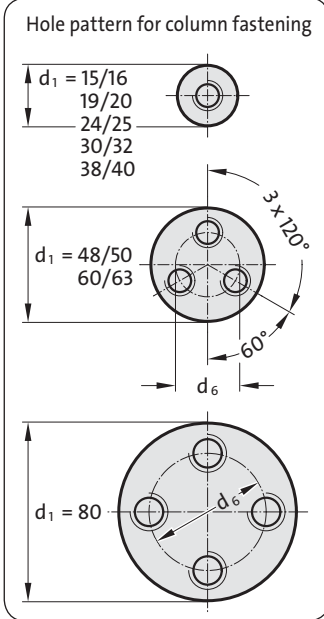

202.31.

Guide Pillars for endwise screw retention, complete with cap screws and washers.

Dimensions on page D19

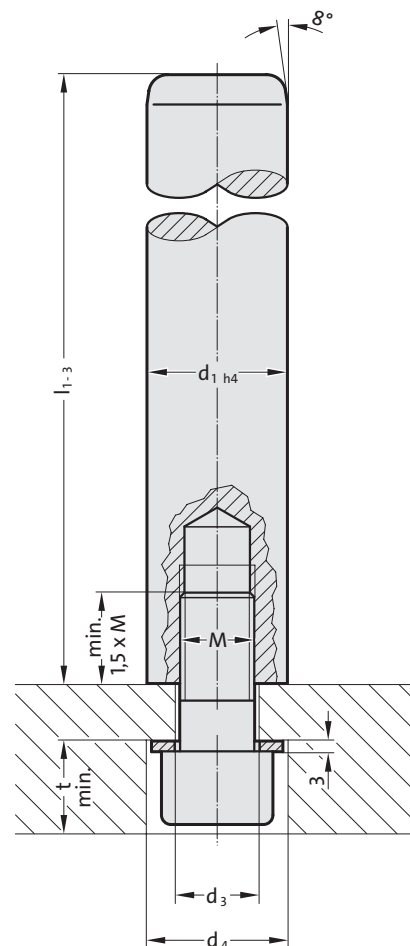

202.31. Dimensions on page D19

						30 32							
d_1	15	16	19	20	24	25	38	40	48	50	60	63	80
d_3	9		11		14		18		14		18		18
d_4	17		20		22		28		22		28		28
d_6	-		-		-		-		28		34		54
t	12		14		16		20,5		16		20,5		20,5
M	8		10		12		16		12		16		16
cap screw	M8x35		M10x40		M12x40		M16x40		3xM12x50		3xM16x60		4xM16x60
Nm*	21		37		85		150		85		200		200

* tightening torque

Ordering Code (example):

Guide Pillar bolt-on type	=	202.31.
$d_1 = 32$ mm	=	032.
$l_1 = 180$ mm	=	180
Order No	=	202.31.032.180

Material: Steel, surface hardened
 Surface Hardness: 60+4 HRC (induction hardened)
 Hardness Penetration: 1,5+1 mm

Note:
 Guide Pillars only recommended for use with sliding guides.

A large, empty rectangular box with rounded corners, occupying most of the page. It is intended for drawing or writing.

Demountable Pillars, conical DIN 9825/ISO 9182-4 AFNOR* with ball cage retainer

FIBRO
2021.50.
2021.58.



2021.58.
Demountable Pillar (Ø 38–63)
with Ball Cage Retainer
Dimensions of ball cage retainer
202.91.: see page D211.



2021.50. **2021.58.**
with Ball Cage Retainer

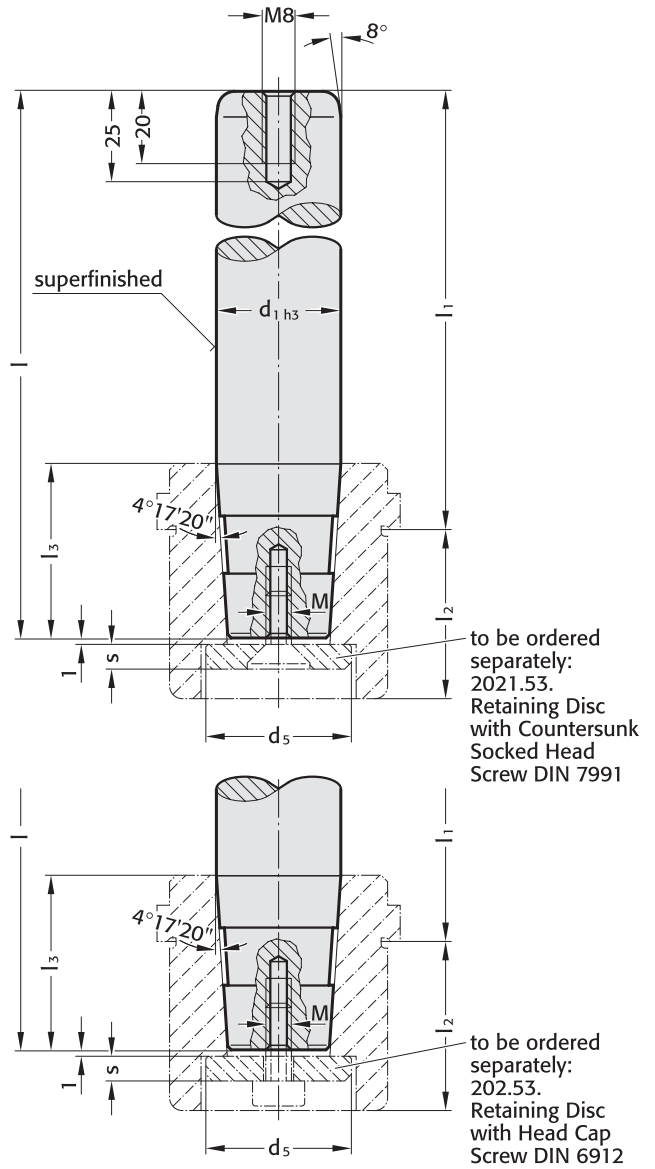

These pillars are recommended where die sharpening etc. demands frequent demounting and re-fitting.

Execution: precision ground, superfinished

Note: manufacturing methods entail that centre holes are not concentric with O. D.

Hardened liner Bushes with matching internal taper for Demountable Pillars 2021.50. with Retaining Disc and Head Cap Screw 202.53. – see page D25.

Hardened liner Bushes with matching internal taper for Demountable Pillars 2021.50. with Retaining Disc and Countersunk Socket Head Screw 2021.53. – see page D24.

Colour Code Combinations/Clearances – see pages D10 and D11.

Material: Steel, surface hardened
Core strength: $\geq 900 \text{ N/mm}^2$
Surface Hardness: 60+3 HRC (induction hardened) Tolerance range yellow = .10
green = .20
red = .30
Penetration: $\geq 1,8 \text{ mm}$

2021.50.		DIN 9825/ISO 9182-4 / AFNOR*																							
d_1	16*	19	20	20*	24	25	25*	30	32	32*	38	40	40*	48	50	50*	60	63	63*						
M	M6×16*	M6×16	M6×16*	M8×20	M8×20	M8×20*	M8×20	M8×20*	M8×20	M8×20*	M8×20	M8×20*	M10×20	M10×20*	M10×25*	M12×30	M12×30	M12×30*	M12×30*						
l_2	30*	30	o. 37	38*	37	o. 47	38*	o. 48*	37	o. 47	48*	o. 61*	47	o. 60	48*	o. 61*	47	o. 60	61*	o. 78*	60	o. 77	78*	o. 98*	
l_3	28*	38	38*	38*	35	o. 45*	48	48*	o. 61*	48	48*	o. 61*	58	58*	o. 78*	69	69	77*	o. 97*						
l_1																									
	82*	100*																							
	95*	113*																							
	100	126	126*	123	123	123*/	–*																		
	112	130*	138	138*	135	135*/	–*	145	145*/	–*															
	125	143*	151	151*	148	148	/158*	158	158*/	–*	158	158*/	–*												
	140	166	166*	163	163*/	–*	173	173*/	186*	173	173*/	–*	180	180*/	–*										
	160	186	186*	183	183	/193*	193	193*/	206*	193	193*/	206*	200	200*/	–*	211									
	180	206	206*	203	203*/	213*	213	213*/	226*	213	213*/	226*	220	220*/	–*	231	237*/	–*							
	200	226	226*	223	223*/	233	233	233*/	–*	233	233*/	–*	240	240*/	260*	251	257*/	–*							
	224			247	247*/	–*	257	257*/	270*	257	257*/	270*	264	264*/	–*	275	*/	–*							
	250			273	273*/	–*	283	283*/	–*	283	283*/	296*	290	290*/	310*	301	307*/	327							
	280	Ordering Code (example):							313	313*		313	313*/	–*	320	320*/	340*	331	337*/	–*					
	315	Demountable Pillar, conical = 2021.50.										348	348*/	–*	355	355*/	375*	366	372*/	392*					
	355	$d_1 = 32 \text{ mm}$				=	032.							395	395*/	–*	406	*/	432*						
	400*	$l_1 = 200 \text{ mm}$				=	200.																		
		$l_3 = 48 \text{ mm}$				=	048.																		
		Tolerance range – yellow										=	10												
		Order No										=	2021.50.032.200.048.10												

FIBRO

2021.53.
202.53.

Retaining Discs

2021.53.

Retaining Disc with Countersunk
Socket Head Screw DIN 9825/ISO 9182-4

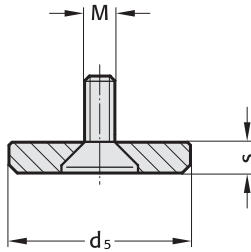

202.53.

Retaining disc with Head cap Screw AFNOR*

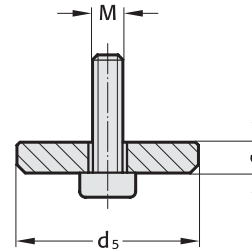

2021.53.

Retaining Disc with Countersunk
Socket Head Screw DIN 9825/ISO 9182-4

Pillar-Ø

d ₁	19	20	24	25	30	32	38	40	48	50	60	63
d _s	22	25	32	32	40	40	50	50	63	63		
s	3	3	3	3	5	5	5	5	6	6		
M	M6×16	M8×20	M8×20	M8×20	M8×20	M10×20	M12×30					

202.53.

Retaining disc with Head cap Screw AFNOR*

Pillar-Ø

d ₁	16	20	25	32	40	50	63
d _s	18	22	25	32	40	50	63
s	3	3	4	4	4	5	6
M	M6×16	M6×16	M8×20	M8×20	M8×20	M10×25	M12×30

Ordering Code (example):

Retaining Disc with Countersunk Socket Head Screw
DIN 9825/ISO 9182-4 = 2021.53.
Pillar-Ø d₁ = 20 mm = 020
Order No = 2021.53.020

Ordering Code (example):

Retaining Disc with Head Cap Screw
AFNOR = 202.53.
Pillar-Ø d₁ = 16 mm = 016
Order No = 202.53.016

Mounting Example:

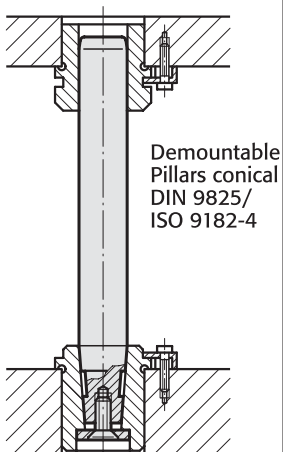

Mounting Example:

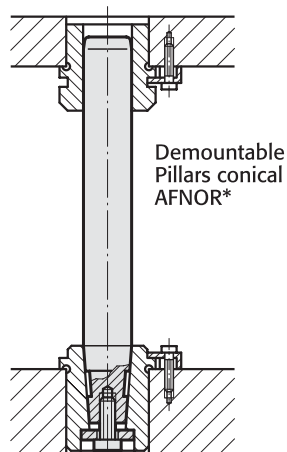

Note:

Not delivered with the demountable Pillar 2021.50., has to be ordered separately:

- 202.53. Retaining Disc with Head Cap Screw DIN 6912 resp.
- 2021.53. Retaining Disc with Countersunk Socked Head Screw DIN 7991

Liner Bushes DIN 9825/ISO 9182-4
for demountable Guide Pillars 2021.50.

2021.39.



Mounting Example:

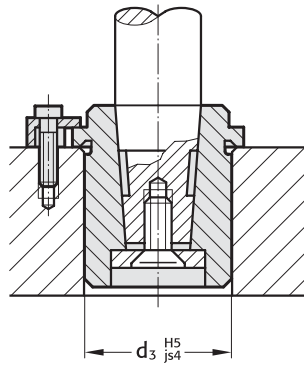

2021.39.

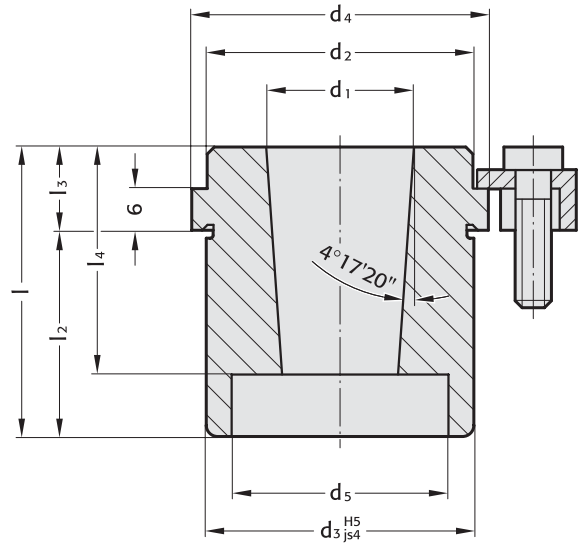

207.45

screw clamps
order No for
replacement parts



207.45

Four screw clamps
for $\varnothing d_1 = 38$
and over
M6 \times 20
similar DIN 6912
head $\varnothing 13$

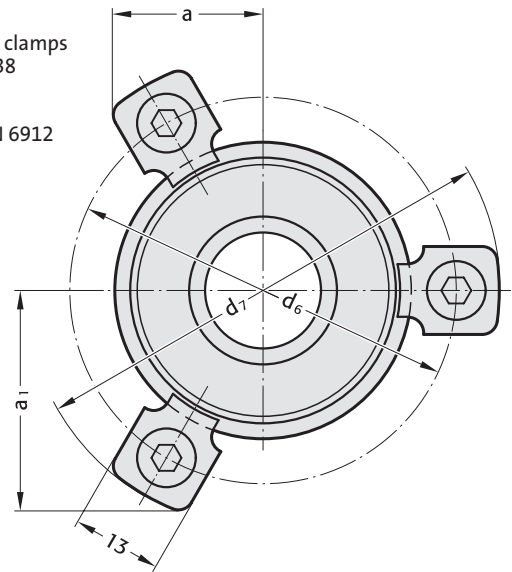

Material:

16 MnCr5
casehardened 58 ± 2 HRC
penetration: $\geq 0,8 - 1,0$ mm

Execution:

Retaining bore, outside diameter and shoulder precision ground.
Supplied with screw clamps and cap screws similar DIN 6912, head $\varnothing 13$.

Note:

Outside diameter d_3 same as that of guide bushes 2081. and 2091.;
see pages D64-D94.

2021.39.

d_1	19	20	24	25	30	32	38	40	48	50	60	63
d_2	32		40		48		58		70		85	
d_3	32		40		48		58		70		85	
d_4	40		48		56		66		80		95	
d_5	23		26		33		41		51		64	
d_6	53		60		67		77		91		106	
d_7	65,7		72,7		79,7		89,7		103,7		118,7	
a	20,9		22,65		24,4		35,3		40,2		45,5	
a_1	30,3		33,4		36,4		35,3		40,2		45,5	
l	42 o. 49		49 o. 59		52 o. 62		62 o. 75		65 o. 78		78 o. 95	
l_2	30 o. 37		37 o. 47		37 o. 47		47 o. 60		47 o. 60		60 o. 77	
l_3	12		12		15		15		18		18	
l_4	39		36		49		49		59		70	

Ordering Code (example):

Liner Bush DIN 9825 = 2021.39.
 $d_1 = 40$ mm = 040.
 $l_2 = 47$ mm = 047
 Order No = 2021.39.040.047

FIBRO

similar AFNOR
210.39.

Liner Bushes for Demountable Guide Pillars 2021.50.

210.39.

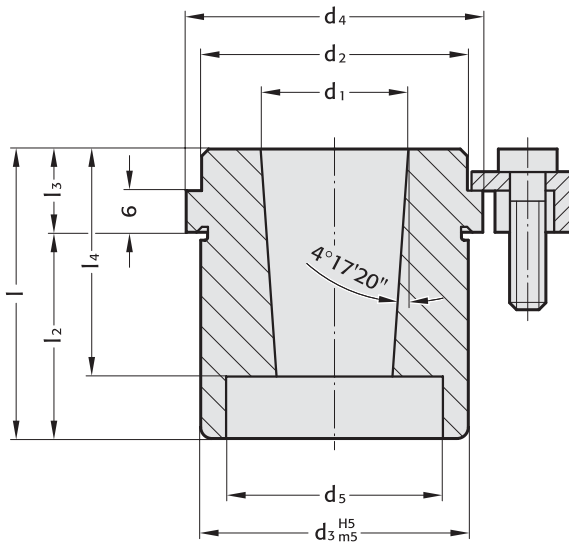

207.45

four screw clamps
ab $\varnothing d_1 = 40$
M6 \times 20
and over
similar DIN 6912
head $\varnothing 13$

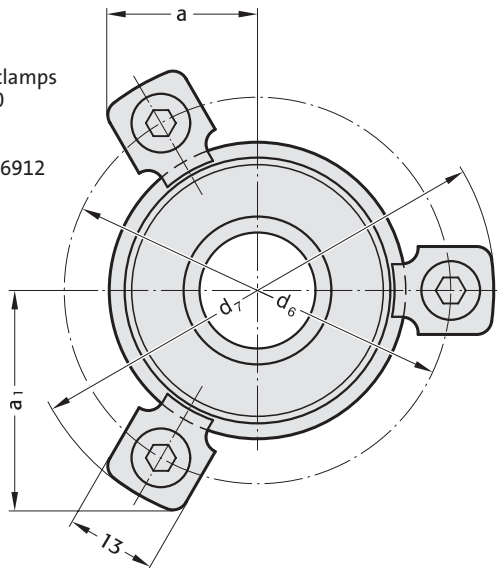

Mounting Example:

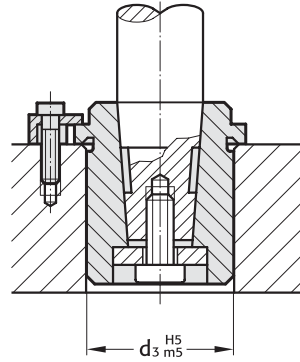

207.45

screw clamps
Order No for
replacement parts

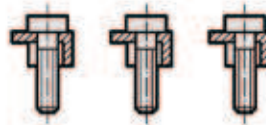

210.39.

d_1	16	20	25	32	40	50	63
d_2	29	32	41	51	65	84	100
d_3	28	32	40	50	63	80	90
d_4	32	36	45	56	70	90	110
d_5	19	23	26	33	41	51	64
d_6	45	49	57	67	81	101	121
d_7	57,7	61,7	69,7	79,7	93,7	113,7	133,7
a	18,9	19,9	21,9	24,4	36	43	50,1
a_1	26,9	28,6	32,1	36,4	36	43	50,1
l	40	50	50/60	63/76	63/76	79/96	98/118
l_2	30	38	38/48	48/61	48/61	61/78	78/98
l_3	10	12	12	15	15	18	20
l_4	30	40	37/47	50/63	50/63	63/80	79/99

Ordering Code (example):

Liner Bush, similar AFNOR	=	210.39.
$d_1 = 40$ mm	=	040.
$l_2 = 48$ mm	=	048
Order No	=	210.39.040.048

Material:

16 MnCr5
casehardened 58 ± 2 HRC
penetration $\geq 0,8 - 1,0$ mm

Execution:

Retaining bore, outside diameter and shoulder precision ground.
Supplied with screw clamps and cap screws similar DIN 6912,
head $\varnothing 13$.

Guide Pillars ~AFNOR with Retaining Ring Groove Clamping Flange and Retaining Ring

FIBRO

2022.25.
2073.46.



2022.25.

Guide Pillar only

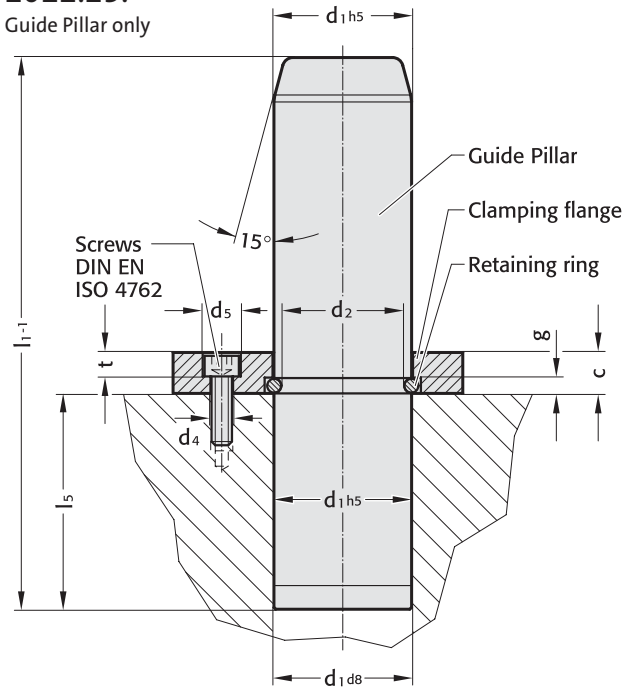

Material:

Steel, surface hardened

Surface hardness: 60 + 4 HRC

Hardness penetration depth: 1,5 + 1 mm

Execution:

Diameter precision ground.

Note:

Matching guide bushes

2102.70. AFNOR – see page D117.

Fit for receiving bore: M6.

Guide pillar is recommended to be used only with Guide Elements with Non-Liquid Lubricant.

Fixing:

Clamping flange with retaining ring screws not included 2073.46. [] []

Retaining ring 2073.46. [] [] .2

2073.46.

Clamping flange
with retaining ring

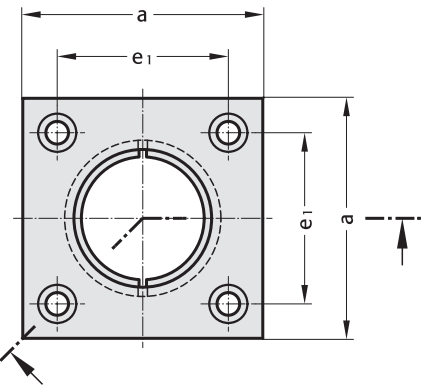

Ordering Code:

Guide Pillar AFNOR without Clamping Flange	= 2022.25.
d ₁ = 40 mm	= 040.
l ₁ = 250 mm	= 250
Order No	= 2022.25.040.250

2022.25.

	25	32	40	50	63	80	100
d ₁	25	32	40	50	63	80	100
d ₂	22,3	27,8	35,8	45,8	56,8	73,8	93,8
d ₄	M6	M6	M6	M8	M10	M12	M12
d ₅	11	11	11	15	18	20	20
a	45	56	70	80	100	110	140
c	10	10	12	14	18	20	20
g	2,7	4,2	4,2	4,2	6,2	6,2	6,2
e ₁	31	36	50	55	70	80	100
t	7	7	7	9	11	13	13
l ₅	25	32	63	80	100	125	160
l ₁ 100	●						
125	●	●					
140	●	●					
160	●	●					
180	●	●	●				
200	●	●	●	●			
220	●	●	●	●	●		
250		●	●	●	●	●	
280			●	●	●	●	
315			●	●	●	●	●
355				●	●	●	●
400				●	●	●	●
450					●	●	●
500					●	●	●

FIBRO

2022.12.
2061.48.

Guide Pillars for Large Tools with Pilot Taper and Snap Ring Groove to Daimler Standard Snap Rings

2022.12.

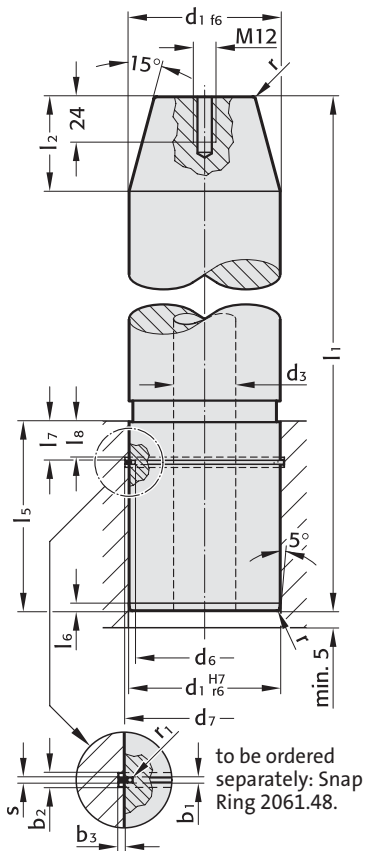

1 x Lifting thread M12
centred only by $\varnothing d_1 = 80$

2 x Lifting thread M8 from $\varnothing d_1 = 100$

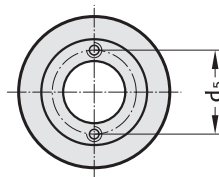

2022.12.

d_1	80	100	125	160
d_3	-	50	65	95
d_5	-	62	82	119
d_6	71,4	89,9	114,9	148,9
d_7	83,2	103,8	128,8	164,3
r	3	3	4	4
r_1	1,05	1,3	1,3	1,3
l_2	50	50	50	50
l_5	100	125	140	180
l_6	4	4	5	5
l_7	21	31	31	31
l_8	20	30	30	30
b_1	2,1	2,6	2,6	2,6
b_2	4,2	5,2	5,2	5,2
b_3	2,8	3,4	3,4	4
s	2,0	2,5	2,5	2,5

Snap ring, outside \varnothing loose	82,6	103,3	128,6	164,3
Snap ring 2061.48.	080	100	125	160

l_1				
280	●			
315	●	●		
355	●	●	●	
400	●	●	●	
450	●	●	●	●
500			●	●
560				●

Ordering Code (example):

Guide Pillar with Groove	=	2022.12.
$d_1 = 80$ mm	=	080.
$l_1 = 315$ mm	=	315
Order No	=	2022.12.080.315

Material:

Steel, surface hardened
Surface hardness: 60 + 4 HRC
Hardness penetration depth: 1,5 + 1 mm

Execution: precision ground

- $\varnothing 80$ without central hole with 1 lifting thread M12 centred
- from $\varnothing 100$ with central hole (through) and with 2 lifting threads M8

Note:

Fit for receiving bore H7
Guide pillar is recommended to be used only with Guide Elements with Non-Liquid Lubricant.

Matching guide bushes:
Page D114, D115 and D117.

Ordering Code (example):

Snap Ring	=	2061.48.
$d_1 = 80$ mm	=	080
Order No	=	2061.48.080

Guide Pillars for Large Tools
with Pilot Taper VDI 3356

2022.15.

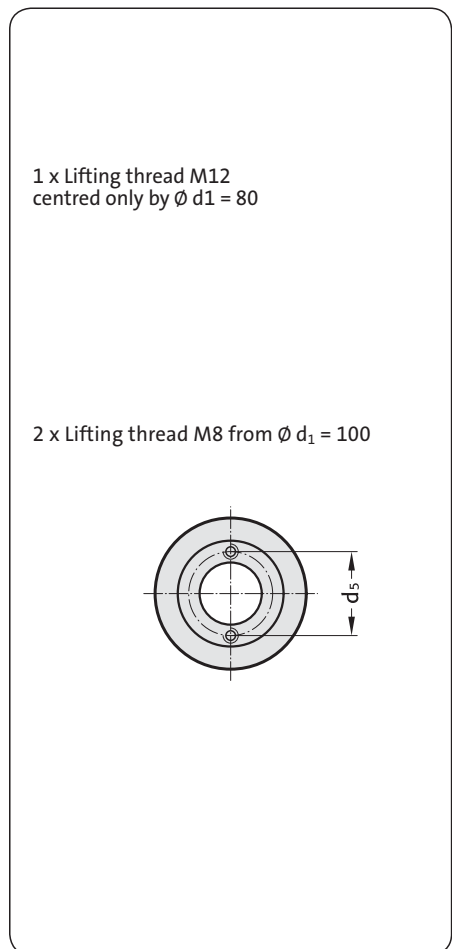
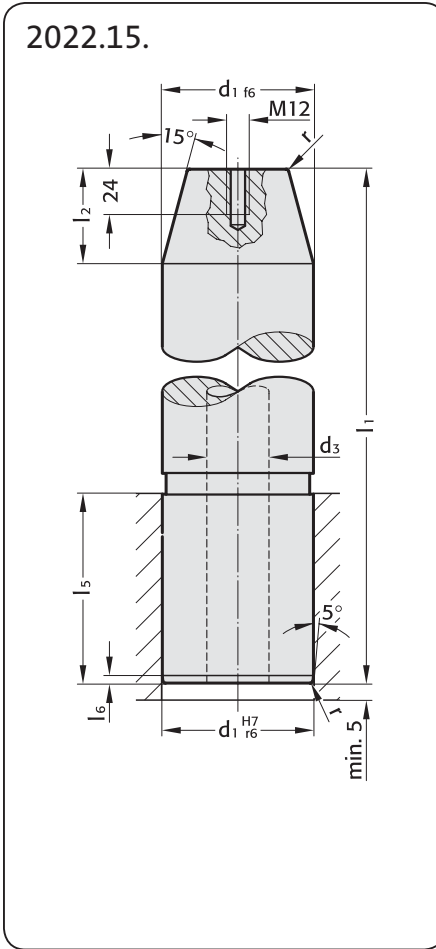

Material:

Steel, surface hardened
Surface hardness: 60 + 4 HRC
Hardness penetration
depth: 1,5 + 1 mm

Execution: precision ground

$\varnothing 80$ without central hole
with 1 lifting thread M12
centred
from $\varnothing 100$ with central hole (through) and
with 2 lifting threads M8

Note:

Fit for receiving bore H7
Guide pillar is recommended to be used
only with Guide Elements with Non-Liquid
Lubricant.
Matching guide bushes:
Page D114, D115 and D117

Ordering Code (example):

Guide Pillar = 2022.15.
 $d_1 = 80$ mm = 080.
 $l_1 = 315$ mm = 315
Order No = 2022.15.080.315

2022.15.

d_1	80	100	125	160
d_3	-	50	65	95
d_5	-	62	82	119
r	3	3	4	4
l_2	50	50	50	50
l_5	100	125	140	180
l_6	4	4	5	5
l_1				
280	●			
315	●	●		
355	●	●	●	
400	●	●	●	
450	●	●	●	●
500			●	●
560				●

FIBRO

2022.17.
2022.40.1.

Guide Pillars for Large Tools with groove to VW Locating plates to VW

2022.17.

1 x Lifting thread M12
centred only by $\varnothing d_1 = 80$

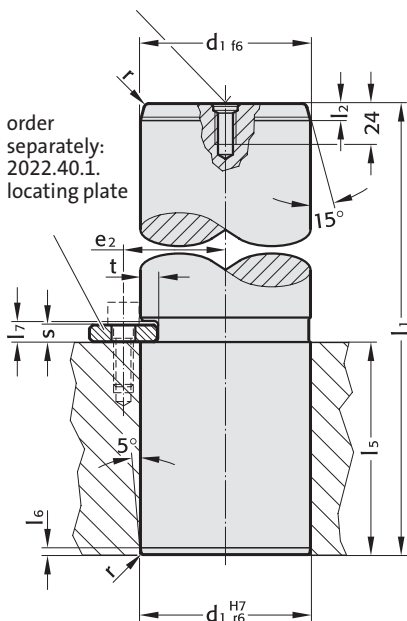

2022.40.1. Locating plate

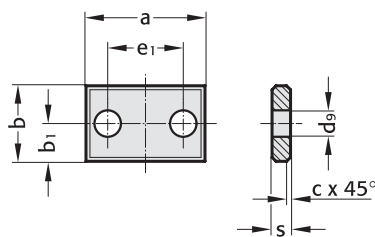

Note:

Screws not included!

Fixing:

Use socket cap screws
DIN EN ISO 4762

M 8x20
M10x30
M12x30.

Ordering Code (example):

Locating plate	=	2022.40.1.
$d_1 = 32$ mm	=	02
Order No	=	2022.40.1.02



2022.17.

d_1	25	32	40	50	63	80
l_2	8	8	8	10	10	10
l_5	40	45	56	70	80	100
l_6	4	4	4	4	4	4
l_7	7	7	10	10	12	12
r	2	2	2	2,5	2,5	3
a	40	40	48	48	60	60
s	5	5	8	8	10	10
c	1	1	2	2	2	2
b	20	20	25	25	34	34
e_1	20	20	24	24	30	30
t	3	3	4	5	6,5	8
e_2	20,5	24	29,5	33,5	43	50
d_9	9	9	11	11	14	14

Order No 2022.40.1. for locating plate
2022.40.1. 02 02 04 04 06 06

l_1						
125	●	●				
140	●	●	●			
160	●	●	●	●		
180	●	●	●	●	●	
200	●	●	●	●	●	
224	●	●	●	●	●	●
250		●	●	●	●	●
280			●	●	●	●
315				●	●	●
355				●	●	●
400					●	●
450						●
500						●

Material:

Steel, surface hardened
Surface hardness: 60 + 4 HRC
Hardness penetration
depth: 1,5 + 1 mm

Execution: precision ground

by $\varnothing d_1 = 80$ with 1 lifting thread
M12

Note:

Fit for receiving bore: H7.

Guide pillar is recommended to be used
only with Guide Elements with Non-Liquid
Lubricant.

Matching guide bushes:
Page D114, D115 and D117.

Ordering Code (example):

Guide Pillar	=	2022.17.
$d_1 = 80$ mm	=	080.
$l_1 = 315$	=	315
Order No	=	2022.17.080.315

2022.19.

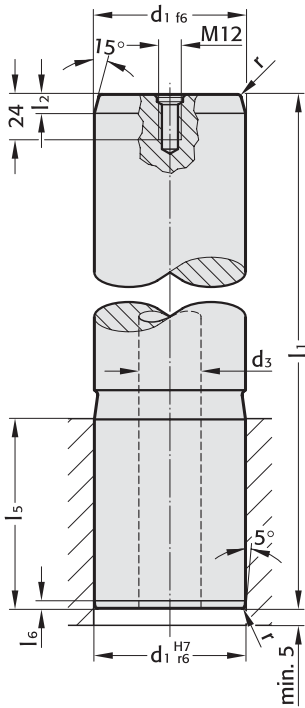

1 x Lifting thread M12 centred only
by $\varnothing d_1 = 80$

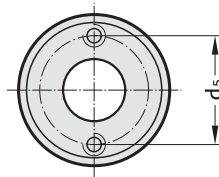

Execution: precision ground

up to $\varnothing d_1 = 80$ without central hole
by $\varnothing d_1 = 80$ with 1 lifting thread M12
from $\varnothing d_1 = 100$ with central hole
(through) and with
2 lifting threads M12



2022.19.

d_1	25	32	40	50	63	80	100	125	160
d_3	-	-	-	-	-	-	50	65	95
d_5	-	-	-	-	-	-	72	90	132
r	2	2	2	2,5	2,5	3	3	4	4
l_2	8	8	8	10	10	10	10	12	12
l_5	40	45	56	70	80	100	125	140	180
l_6	4	4	4	4	4	4	4	5	5
l_1									
125	●	●							
140	●	●	●						
160	●	●	●	●					
180	●	●	●	●	●				
200	●	●	●	●	●	●			
224	●	●	●	●	●	●	●		
250		●	●	●	●	●	●	●	
280			●	●	●	●	●	●	●
315				●	●	●	●	●	●
355				●	●	●	●	●	●
400					●	●	●	●	●
450						●	●	●	●
500						●	●	●	●
560									●

Material:

Steel, surface hardened
Surface hardness: 60 + 4 HRC
Hardness penetration
depth: 1,5 + 1 mm

Execution:

Fit for receiving bore: H7.
Guide pillar is recommended to be used
only with Guide Elements with Non-Liquid
Lubricant.

Matching guide bushes:
Page D114, D115 and D117.

Ordering Code (example):

Guide Pillar	= 2022.19.
$d_1 = 40$ mm	= 040.
$l_1 = 200$ mm	= 200
Order No	= 2022.19.040.200

Guide Pillar
with 5° Pilot Taper to VW Standard

2022.13.

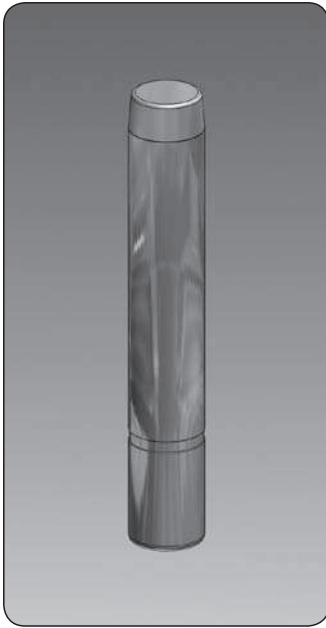

Mounting Example:

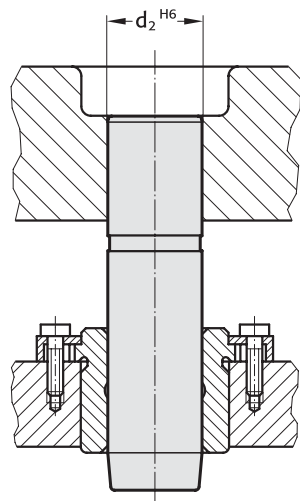

2022.13.

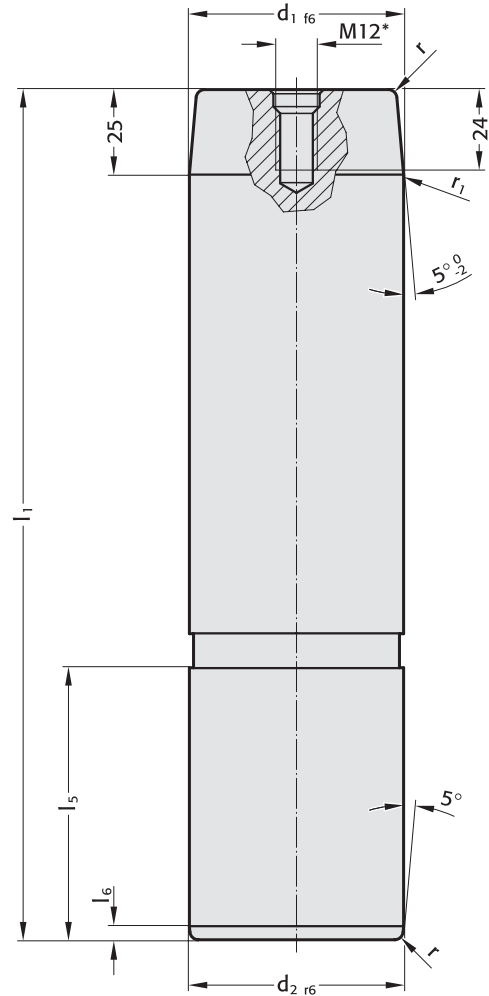

Material:

Steel, surface hardened
Surface hardness: 60 + 4 HRC
Hardness penetration depth: 1.5 + 1 mm

Execution:

precision ground
*by $\varnothing d_1 = 80$ with 1 centered lifting thread M12

Note:

Fit for receiving bore H6
Guide pillar is recommended to be used only with Guide Elements with Non-Liquid Lubricant.
Matching guide bushes:
Page D114, D115 and D117.

Application:

floating support in upper half of trimming tools.

Ordering Code (example):

Guide Pillar = 2022.13.
 $d_1 = 40$ mm = 040.
 $l_1 = 200$ mm = 200
 Order No = 2022.13.040.200

2022.13.

	40	50	63	80
d_1	40	50	63	80
d_2	40	50	63	80
l_5	56	70	80	100
l_6	4	4	4	4
r	2	2,5	2,5	3
r_1	3	5	6	8
l_1				
140	●			
160	●	●		
180	●	●	●	
200	●	●	●	
224	●	●	●	●
250	●	●	●	●
280	●	●	●	●
315		●	●	●
355		●	●	●
400			●	●

**Guide Pillars with Collar to WDX
Screw Clamps**

**2022.29.
2072.46**



Mounting Example

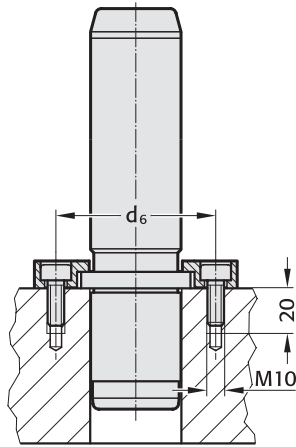

2022.29.

without Screw Clamps

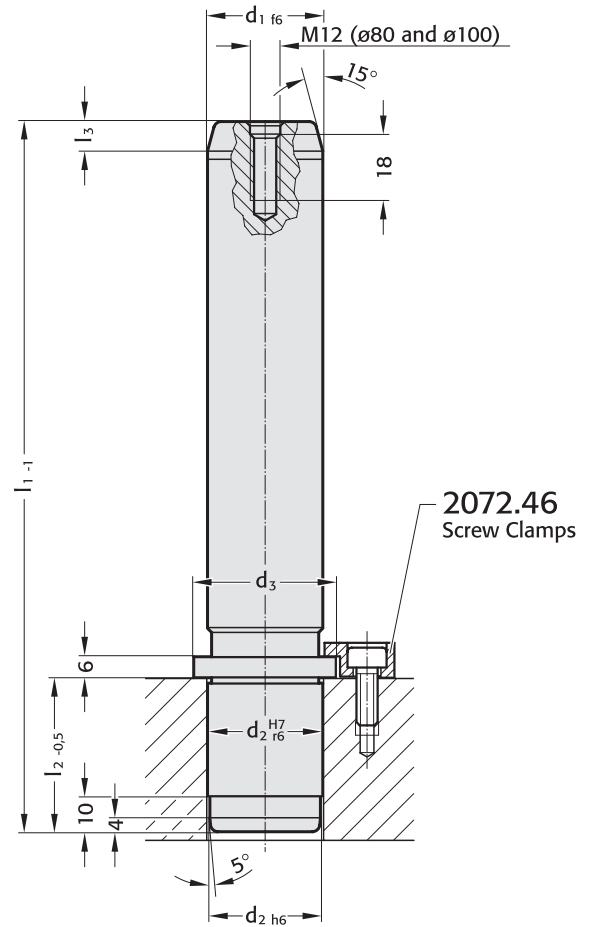

Material:

Steel, surface hardened
Surface hardness: 60 + 4 HRC
Hardness penetration depth: 1,5 + 1 mm

Execution: precision ground

Remark: method of manufacture entails that centre holes are not concentric with O. D.

Guide pillar is recommended to be used only with Guide Elements with Non-Liquid Lubricant

Fit for receiving bore: H7.

Fixing: (to be ordered separately)

Screw Clamps with Screws 2072.46 (M10 x 20 DIN EN ISO 4762), see page D216

up to Ø 50 2 screw clamps
from Ø 63 3 screw clamps

Ordering Code (example):

Guide Pillar = 2022.29.
d₁ = 32 mm = 032.
l₁ = 140 mm = 140
Order No = 2022.29.032.140

2022.29.

d ₁	25	32	40	50	63	80	100
d ₂	25	32	40	50	63	80	100
d ₃	32	40	50	60	80	90	110
d ₆	68	75	83	93	106	123	143
l ₂	40	42	56	70	80	100	125
l ₃	6	8	8	10	10	10	10
l ₁							
125	●						
140	●	●					
160	●	●	●	●			
180	●	●	●	●			
200	●	●	●	●	●		
224	●	●	●	●	●	●	
250		●	●	●	●	●	
280			●	●	●	●	●
315				●	●	●	●
355					●	●	●
400					●	●	●
500						●	●

FIBRO

2021.44. 2021.46.
2021.43.

Demountable Pillars DIN 9825/~ISO 9182-5 with Collar and Screw Clamp Retention Disc with Screw for Central Retention

2021.46.
with Screw Clamps

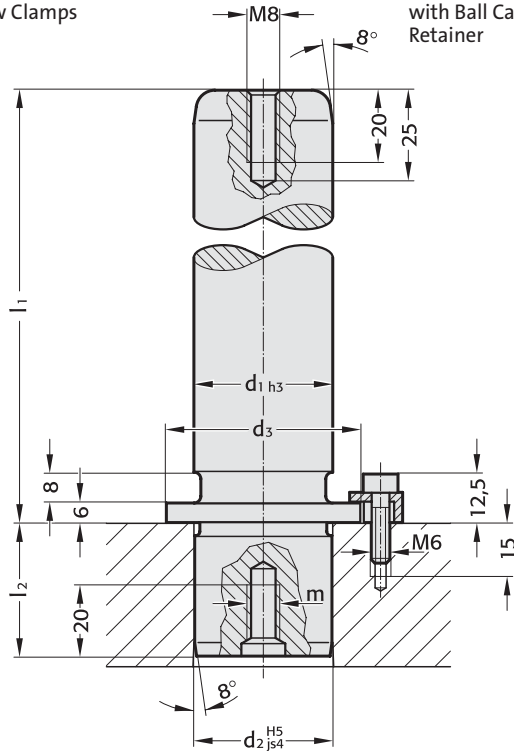

2021.44.
with Ball Cage Retainer

207.45

Screw Clamps,
incl. Screws

Order-No for
replacement parts

for $\varnothing d_1 = 38$ and over:
4 screw clamps

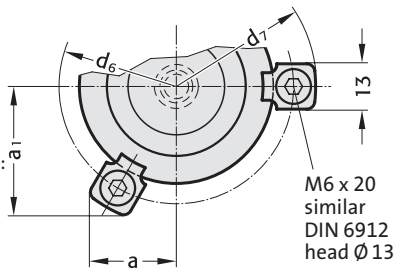

Ordering Code (example):

Demountable Pillar	=	2021.46.
$d_1 = 32$ mm	=	032.
$l_1 = 180$ mm	=	180
Tolerance range red	=	.30
Order No	=	2021.46.032.180.30

Mounting Example

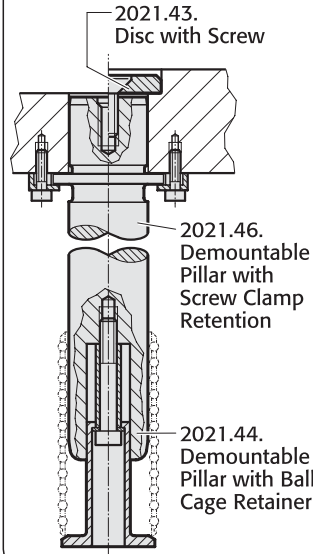

2021.43.

Disc with Screw

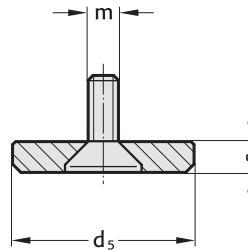

Ordering Code (example):

Disc with Screw	=	2021.43.
$d_1 = 32$ mm	=	032
Order No	=	2021.43.032



2021.44.

Demountable Pillar ($\varnothing 38-63$)
with Ball Cage Retainer

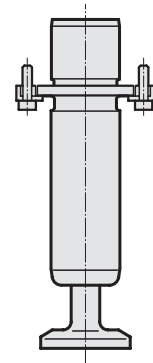

Dimensions of ball cage
retainer:
See 202.91., page D211.

2021.46./2021.44.

Material: Steel, surface hardened

Core strength: ≥ 900 N/mm²

Surface Hardness: 60 + 3 HRC (induction hardened)

Hardness Penetration: $\geq 1,8$ mm

Execution: fine precision ground

Note: method of manufacture entails that centre
holes are not concentric with O. D.

Demountable pillars with collar are suited to applications
where die sharpening requires dismantling and re-fitting.

Tolerance range – yellow = .10
green = .20
red = .30

Note:
Colour Code Combinations/Clearances - see pages D10 and D11.

2021.46./2021.44./2021.43.

d_1	15 16	19 20	24 25	30 32	38 40	48 50	60 63	80
d_2	15 16	19 20	24 25	30 32	38 40	48 50	60 63	80
d_3	22	25	32	40	50	63	80	95
d_5	22	25	32	40	50	60	70	93
d_6	33	36	43	51	61	74	91	106
d_7	45,7	48,7	55,7	63,7	73,7	86,7	103,7	118,7
a	15,9	16,6	18,4	20,4	29,2	33,8	39,8	46,2
a_1	21,7	23	26	29,5	29,2	33,8	39,8	46,2
m	M8	M8	M8	M8	M8	M8	M8	M12
s	6	6	6	6	6	6	6	12
l_2	20	23	30	37	37	47	47	60
l_1	100	●	●	●				
112	●	●	●	●	●			
125	●	●	●	●	●	●		
140	●	●	●	●	●	●	●	
160	●	●	●	●	●	●	●	●
180	●	●	●	●	●	●	●	●
200	●	●	●	●	●	●	●	●
224			●	●	●	●	●	●
250			●	●	●	●	●	●
280				●	●	●	●	●
315				●	●	●	●	●
355					●	●	●	●
400						●	●	●

2021.29.

Guide Pillars with Collar

2021.29.

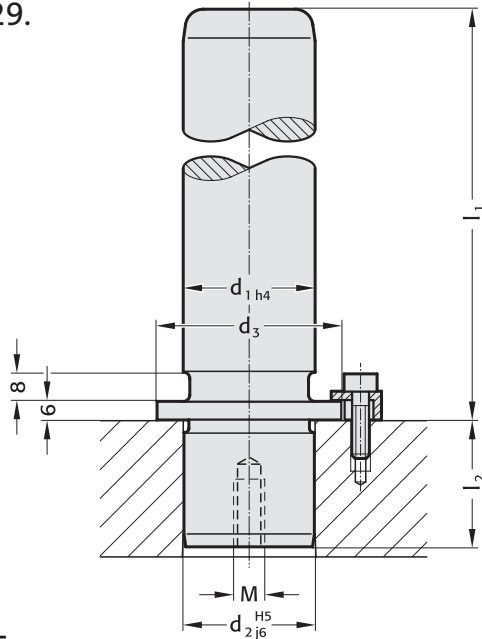

207.45

Screw Clamps,
incl. Screws
Order-No for
replacement parts

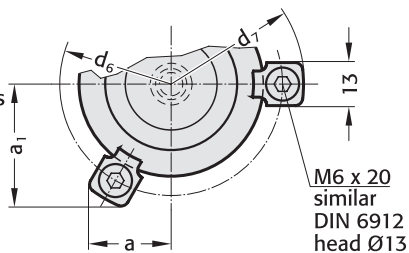

2021.29.

Material:

Steel, surface hardened
Surface hardness: 60 + 4 HRC
Hardness penetration
depth: 1,5 + 1 mm

Note:

Guide Pillar only recommended for use with sliding guides

Ordering Code (example):

Guide Pillar with Collar	=	2021.29.
d ₁ = 32 mm	=	032.
l ₁ = 180 mm	=	180
Order No	=	2021.29.032.180

2021.29. / 2021.43.

d ₁	15	16	19	20	24	25	30	32	38	40	48	50	60	63	80
d ₂	15	16	19	20	24	25	30	32	38	40	48	50	60	63	80
d ₃	22	25	32	40	50	63	80	95							
d ₅	22	25	32	40	50	60	70	93							
d ₆	33	36	43	51	61	74	91	106							
d ₇	45,7	48,7	55,7	63,7	73,7	86,7	103,7	118,7							
d ₈	24	27	34	42	52	62	72	95							
a	15,9	16,6	18,4	20,4	29,2	33,8	39,8	46,2							
a ₁	21,7	23	26	29,5	29,2	33,8	39,8	46,2							
M	M8	M8	M8	M8	M8	M8	M8	M12							
s	6	6	6	6	6	6	6	12							
l ₃	20,5	23,5	30,5	37,5	37,5	47,5	47,5	60,5							
t ₅	6,5	6,5	6,5	6,5	6,5	6,5	6,5	12,5							
l ₂	20	23	30	37	37	47	47	60							

l ₁	100	●	●	●											
	112	●	●	●	●										
	125	●	●	●	●	●									
	140	●	●	●	●	●	●								
	160	●	●	●	●	●	●	●							
	180	●	●	●	●	●	●	●	●						
	200	●	●	●	●	●	●	●	●	●					
	224			●	●	●	●	●	●	●	●				
	250			●	●	●	●	●	●	●	●	●			
	280				●	●	●	●	●	●	●	●	●		
	315					●	●	●	●	●	●	●	●	●	
	355						●	●	●	●	●	●	●	●	●
	400							●	●	●	●	●	●	●	●

2021.29.

**Assembly of
Guide
Elements:**

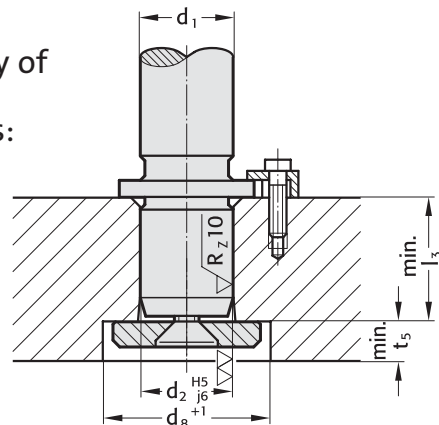

2021.43.

**Retaining Disc with
Countersunk Socket
Head Screw**

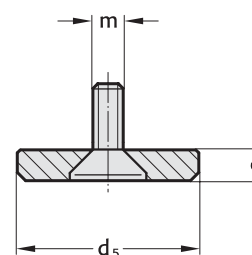

Ordering Code (example):

Disc with screw	=	2021.43.
d ₁ = 32 mm	=	032
Order No	=	2021.43.032

Ball Guides for highest stroking speeds

206.41. 2061.44./2062.44.
202.61.



206.41.

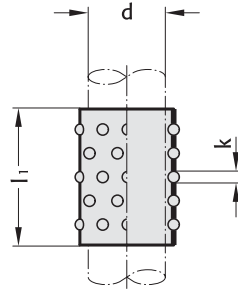

206.41.

Order No	d	l1	k
206.41.012.020.021	12	21	2
206.41.012.020.042	12	42	2
206.41.012.025.021	12	21	2,5
206.41.012.025.042	12	42	2,5
206.41.015.030.045	15	45	3
206.41.015.030.056	15	56	3
206.41.015.030.063	15	63	3
206.41.015.030.071	15	71	3



2062.44.012.
2061.44.015.

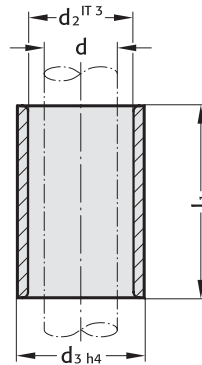

2062.44.012.

Order No	d	d2	d3	l1	for Ball Ø
2062.44.012.016.032	12	16	20	32	2
2062.44.012.017.032		17			2,5

Tolerance range xx
yellow = .10
green = .20

2061.44.015.

Order No	d	d2	d3	l1	for Ball Ø
2061.44.015.023.xx	15	21	28	23	3
2061.44.015.030.xx				30	
2061.44.015.037.xx				37	
2061.44.015.047.xx				47	
2061.44.015.060.xx				60	



202.61.

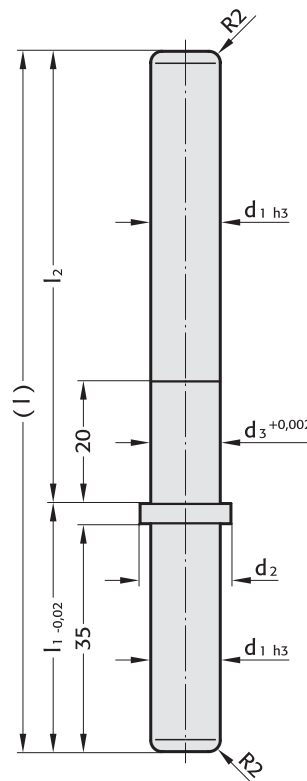

202.61

Order No	d1	d2	d3	l	l1	l2
202.61.012.041.074	12	15,9	12,02	115	41	74
202.61.015.044.080	15	23,5	15,02	124	44	80

Material:

- Cage: polyacetal tubing
- Balls: Rolling bearing steel 100 Cr6 Quality Class 1, DIN 5401
- Guide bush: tool steel, hardened to 62±2 HRC
- Guide pillar: Steel, surface hardened
- hardness penetration 1±0,2 mm

Discription:

Owing to its much lower inertia, the plastic ball cage of particular advantage in die sets operating at stroking speed of 1000 SPM and more.

The phenomenon of ball-drag at the reversal point of cage travel, set up by the cage inertia, no longer occurs. The negative influence of this drag is eliminated – and so are the wear symptoms associated with it.

On small modular die sets the combination plastic ball cage/collared guide pillar 202.61. has indeed been successful for several years.

Cages with ball sizes 2 mm, 2,5 and 3 mm are supplied with matching guide bushes.

**Demountable Guide Pillars,
with centre fixing**

2020.63.

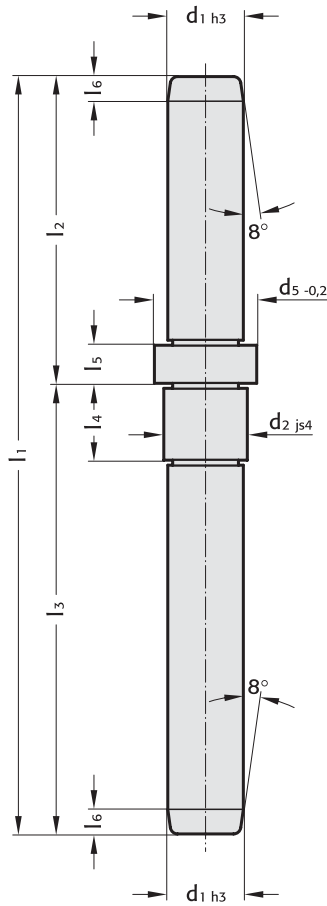

Mounting Example:

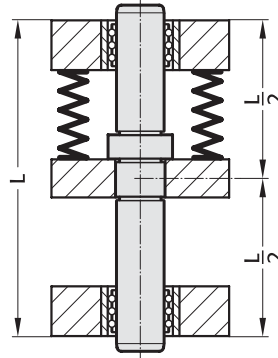

Description:

For press fit into register bore N5.

The transverse load resistance of tool guides is greatly influenced by the position of the guide pillar fixing.

For a tool with a spring-mounted die guide plate and pillar fixing at the top or bottom of the tool, the deflection and pillar bending values do not differ when the load is applied at the side since the distance (L) from the point of application of the force is the same.

Significantly better pillar bending values can be achieved by fixing the guide pillars in the die guide plate, i.e. in the centre of the pillar.

Since the distance ($\frac{L}{2}$) between the point of application of the force and the fixing surface is thus halved, the load-bearing capacity is increased by eight times.

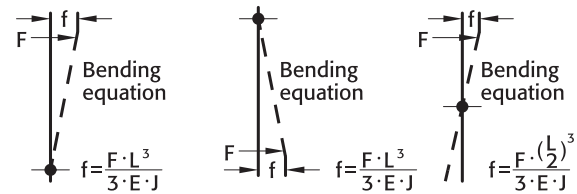

2020.63.

d_1	12	16
d_2	13	18
d_5	15,9	21,9
l_1	116	158
l_2	42	64
l_3	74	94
l_4	12,5	16
l_5	5	8
l_6	3	5

Ordering Code (example):

Demountable Guide Pillars	=	2020.63.
$d_1 = 12$ mm	=	012.
$l_2 = 42$ mm	=	042.
$l_3 = 74$ mm	=	074
Order No	=	2020.63.012.042.074

Material:

Steel, surface hardened

surface hardness: 62+2 HRC case hardened

hardness penetration: $1 \pm 0,2$ mm

Stripper-Mounted Pillars

2020.62.



Mounting Example

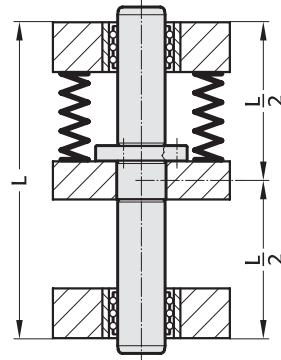

2020.62.

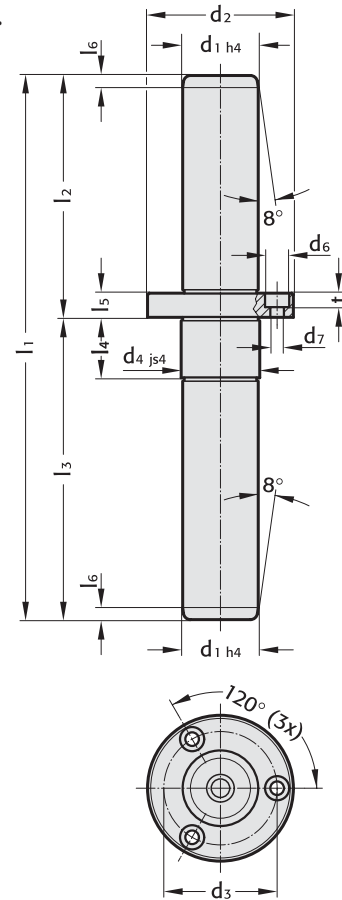

Description:

The transverse load resistance of tool guides is greatly influenced by the position of the guide pillar fixing.

For a tool with a spring-mounted die guide plate and pillar fixing at the top or bottom of the tool, the deflection and pillar bending values do not differ when the load is applied at the side since the distance (L) from the point of application of the force is the same.

Significantly better pillar bending values can be achieved by fixing the guide pillars in the die guide plate, i.e. in the centre of the pillar.

Since the distance ($\frac{L}{2}$) between the point of application of the force and the fixing surface is thus halved, the load-bearing capacity is increased by eight times.

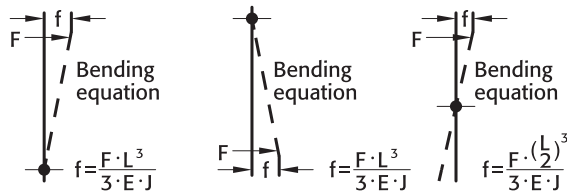

Material: Steel, heat treated
 Core strength: $\geq 900 \text{ N/mm}^2$
 Surface Hardness: 60 + 3 HRC (induction hardened)
 Hardness Penetration: $\geq 2,0 + 1,6 \text{ mm}$

Execution: precision ground

Note: Use hexagon socket head cap screws
 DIN EN ISO 4762 12.9
 Colour Code Combinations/Clearances – see pages D10 and D11.

Diameter 12 only available in Tolerance range yellow = .10

Ordering Code (example):

Stripper-Mounted Pillar		Tolerance range
with centre fixing	= 2020.62.	yellow = .10
d ₁ = 12 mm	= 012.	green = .20
l ₂ = 50 mm	= 050.	red = .30
l ₃ = 60 mm	= 060.	
Tolerance range – yellow	= 10	
Order No	= 2020.62.012.050.060.10	

2020.62.

d ₁	d ₂	d ₃	d ₄	d ₆	d ₇	t	l ₁	l ₂	l ₃	l ₄	l ₅	l ₆
12	28	20	13	6	3,4	3,4	90	40	60			
							100	50	70			
							110	60	80			
							120	70	90			
							130	80	100			
							140	90	110			
16	38	28	18	8	4,5	4,6	140	60	80	16	8	4
							150	70	90			
							160	80	100			
							170	90	110			
							180	100	120			
							190	110	130			
19	42	32	22	8	4,5	4,6	160	70	90	20	8	4
							170	80	100			
							180	90	110			
							190	100	120			
							200	110	130			
							210	120	140			
25	48	38	26	8	4,5	4,6	180	80	100	22	8	6
							190	90	110			
							200	100	120			
							210	110	130			
							220	120	140			
							230	130	150			
32	60	48	34	10	5,5	5,7	180	80	100	25	10	7
							190	90	110			
							200	100	120			
							210	110	130			
							220	120	140			
							230	130	150			
							240	140	160			
40	70	56	42	11	6,6	6,8	200	90	110	27	12	7
							210	100	120			
							220	110	130			
							230	120	140			
							240	130	150			
							250	140	160			
							260	150	170			

202.60.
Stripper-Mounted Pillars
with ring nut

Always use shouldered
face as bearing surface!

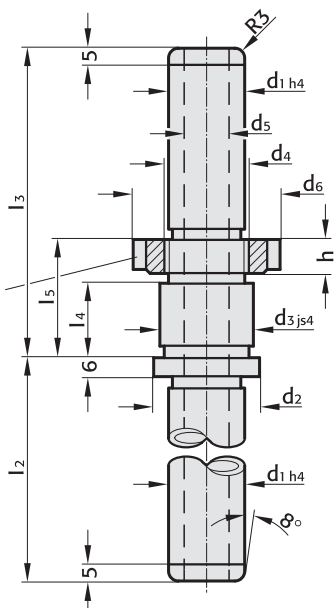

Mounting Example

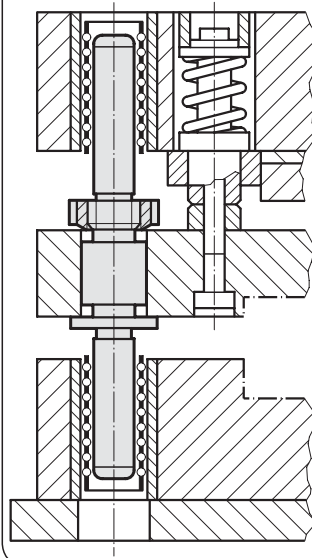

Description:

The transverse load resistance of tool guides is greatly influenced by the position of the guide pillar fixing.

For a tool with a spring-mounted die guide plate and pillar fixing at the top or bottom of the tool, the deflection and pillar bending values do not differ when the load is applied at the side since the distance (L) from the point of application of the force is the same.

Significantly better pillar bending values can be achieved by fixing the guide pillars in the die guide plate, i.e. in the centre of the pillar.

Since the distance ($\frac{L}{2}$) between the point of application of the force and the fixing surface is thus halved, the load-bearing capacity is increased by eight times.

In order to keep moving mass to a minimum and thereby minimize detrimental forces of inertia, FIBRO Stripper-Mounted Pillars are made with a hollow core. Rigidity of the die set – of paramount importance – remains unaffected by the hollow design.

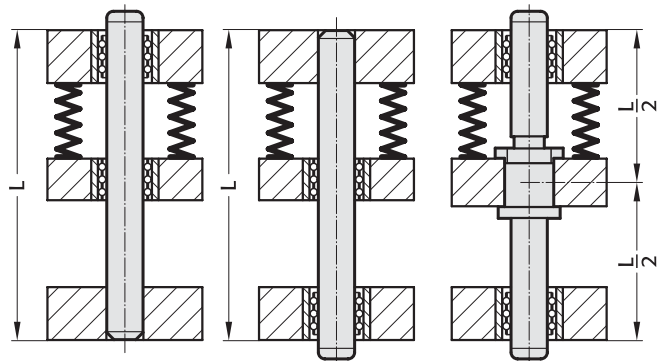

Bending equation
 $f = \frac{F \cdot L^3}{3 \cdot E \cdot J}$

Bending equation
 $f = \frac{F \cdot L^3}{3 \cdot E \cdot J}$

Bending equation
 $f = \frac{F \cdot (\frac{L}{2})^3}{3 \cdot E \cdot J}$

202.60.

d ₁	19	25	32	40
d ₂	32	38	46	56
d ₃	25	30	36	46
d ₄	M22 × 1,5	M28 × 1,5	M35 × 1,5	M45 × 1,5
d ₅	8	12	20	28
d ₆	40	50	55	68
h	9	10	11	12
l ₂	80	80	100	100
l ₃	120	120	140	140
l ₄	29	29	34	34
l ₅	45	45	50	50

Shorter lengths l₂ and l₃ available on request

Ordering Code (example):

Stripper-Mounted Pillar with Collar and ring nut retention	= 202.60.
d ₁ = 25 mm	= 025.
l ₂ = 80 mm	= 080.
l ₃ = 120 mm	= 120.
Tolerance range – green	= 20
Order No	= 202.60.025.080.120.20

Material:

Steel, surface hardened
Core strength: $\geq 900 \text{ N/mm}^2$
Surface Hardness: 60+3 HRC (induction hardened)
Hardness Penetration: $\geq 1,8 \text{ mm}$

Execution:

precision ground

Note:

Colour Code Combinations/Clearances – see pages D10 and D11.

Tolerance range
yellow = .10
green = .20
red = .30

Ordering Code (example):

ring nut only to DIN 1804-h = 202.60. 0 2 15
d₁

Stripper-Mounted Retaining Bushes,
conical pillar fit

2021.64.



Mounting Example:

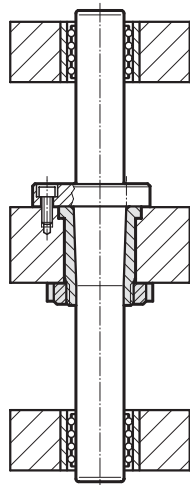

2021.64.

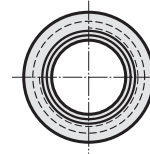
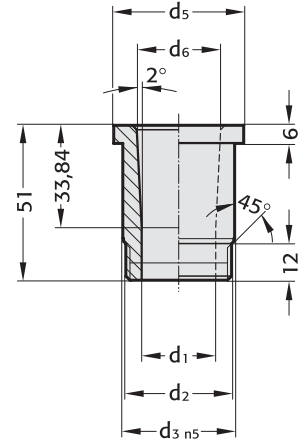

2073.48.

DIN 1804

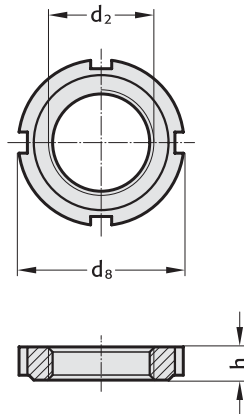

Ordering Code (example):

Ring Nut = 2073.48.
 $d_2 = M40 \times 1,5 = 040.15$
 Order No = 2073.48.040.15

Material: Retaining bushes 16 MnCr5

Surface hardness: Case hardened 60 ± 2 HRC

Hardness Penetration: $\geq 0,8 - 1$ mm

Execution: Thread not hardened

Note: Guide pillar 2020.64.

2021.64.

d_1	25,5	32,5
d_2	M35 × 1,5	M40 × 1,5
d_3	37	44
d_5	43	50
d_6	27,86	34,86
d_8	55	62
h	11	12

Available upon request!

Ordering Code (example):

Retaining Bush, conical = 2021.64.
 $d_1 = 32$ mm = 032
 Order No = 2021.64.032

**Stripper Mounted Guide Pillars
conical, with centre fixing**

2020.64.

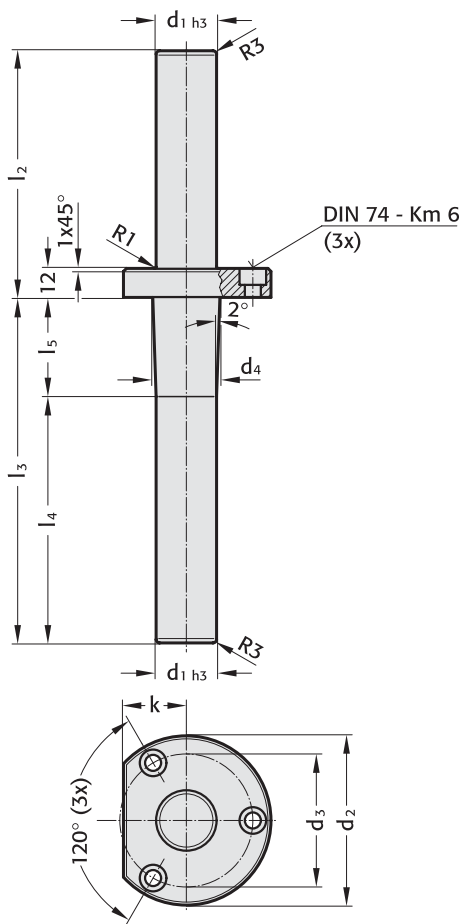

Mounting Example:

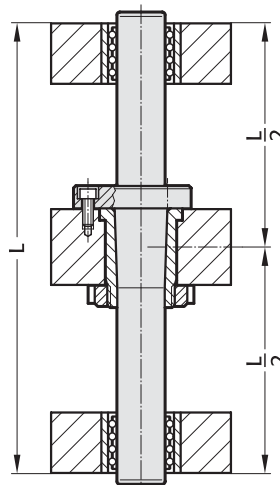

Description:

The transverse load resistance of tool guides is greatly influenced by the position of the guide pillar fixing.

For a tool with a spring-mounted die guide plate and pillar fixing at the top or bottom of the tool, the deflection and pillar bending values do not differ when the load is applied at the side since the distance (L) from the point of application of the force is the same.

Significantly better pillar bending values can be achieved by fixing the guide pillars in the die guide plate, i.e. in the centre of the pillar.

Since the distance ($\frac{L}{2}$) between the point of application of the force and the fixing surface is thus halved, the load-bearing capacity is increased by eight times.

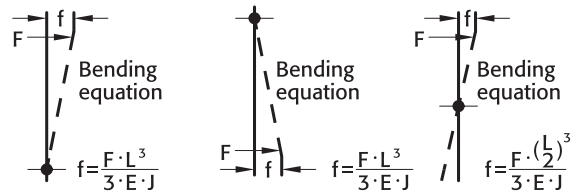

2020.64.

d ₁	d ₂	d ₃	d ₄	k	l ₂	l ₃	l ₄	l ₅
25	70	55	27,86	26	102	143	102	41
					122	143	102	41
32	76	62	34,86	30	102	143	102	41
					122	143	102	41
					122	153	112	41
					137	153	112	41
					142	153	112	41
					162	153	112	41

Available upon request!

Ordering Code (example):

Guide Pillar, conical with centre fixing	=	2020.64.
d ₁ = 25 mm	=	025.
l ₂ = 102 mm	=	102.
l ₃ = 143 mm	=	143.
Tolerance range – yellow	=	10
Order No	=	2020.64.025.102.143.10

Material:

Steel
hardened to 62±2 HRC

Execution:

Precision ground

Note:

Retaining Bush 2021.64.

Use screws conforming to DIN EN ISO 4762 12.9

Tolerance range yellow = .10
 green = .20

2024.94.



2024.94.

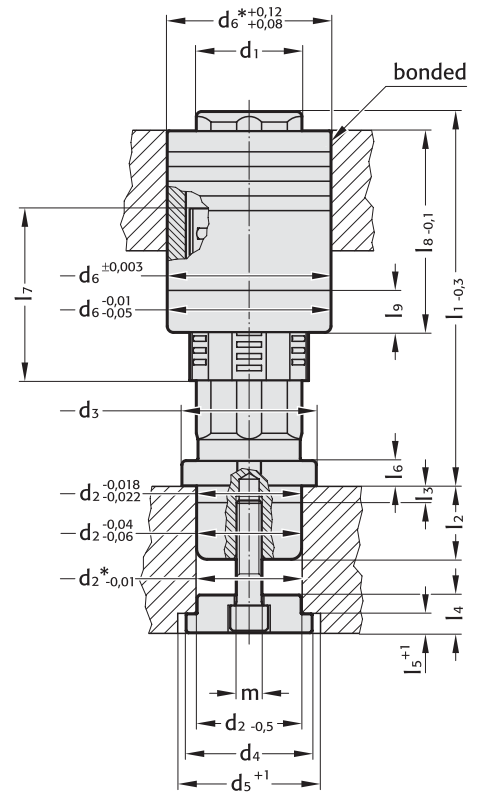

*mounting bore

Cross section of guide unit

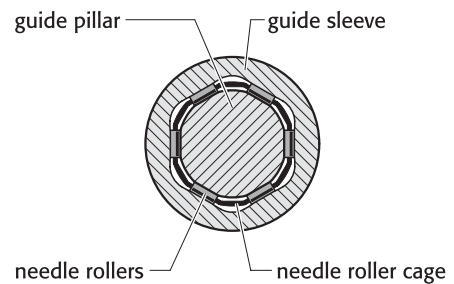

- Ø 16 4 Running surfaces
- Ø 12, Ø 20 - Ø 60 6 Running surfaces
- Ø 80 8 Running surfaces

The secret of the high rigidity, robustness and guide accuracy of FIBRO Million Guide guide units is the large surface area of the needle rollers.

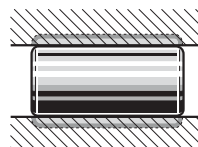

FIBRO

2024.94.

Million Guide - Guide Units

Description:

FIBRO Million Guide guide units are used wherever rigidity, robustness and a precision guide function is required. For stroke speeds up to 50 m/min and temperatures up to 80 °C.

Version:

Guide unit 2024.94 consisting of paired guide pillar and guide sleeve, needle roller cage and disk for fixing the guide column. The fixing screw is ordered separately (see C40, C41) as the screw required depends on the thickness of the base plate.

Materials:

Needle roller cage: plastic
 Needle rollers: steel, hardened
 Guide sleeve: tool steel alloy, hardened, 60±2 HRC
 Guide pillar: tool steel alloy, hardened, 60±2 HRC
 Disk: Steel

Note:

Guide units must be installed in accordance with the Instructions.

2024.94.

d ₁	12	16	20	25	30	32	40	50	60	80
d ₂	12	16	20	25	30	32	40	50	60	80
d ₃	18	24	29	35	40	42	54	64	74	98
d ₄	16	22	26	32	38	40	50	60	72	105
d ₅	18	24	28	34	38	40	50	60	72	105
d ₆	23	30	37	44	50	54	68	78	95	120
m	M5x8	M6x10	M8x20	M8x20	M10x25	M10x25	M12x30	M12x30	M14x30	M16x30
l ₂	12	16	20	25	30	30	35	35	42	45
l ₃	6	6	8	8	8	8	8	8	15	15
l ₄	7	10	13	13	16	16	18	18	20	26
l ₅	3	4	5	5	7	7	9	9	12	13
l ₆	5	6	8	8	9	9	10	12	15	15
l ₇	29,8	30	52	62	68	68	78	82	116	132
l ₈	40	40	60	70	78	78	92	96	120	145
l ₉	-	-	20	20	20	20	20	20	20	25
l ₁ 50	●									
60	●									
70	●									
80	●	●	●							
90	●	●	●							
100	●	●	●	●	●	●				
110	●	●	●	●	●	●				
120	●	●	●	●	●	●	●			
130		●	●	●	●	●	●			
140				●	●	●	●			
150				●	●	●	●	●	●	
160				●	●	●	●	●	●	●
170					●	●	●	●	●	●
180					●	●	●	●	●	●
190					●	●	●	●	●	●
200					●	●	●	●	●	●
210							●	●	●	●
220							●	●	●	●
230								●	●	●
240								●	●	●
250								●	●	●
260										●
270										●
280										●

Ordering Code (example):

Guide unit
 Million Guide = 2024.94.
 d₁ = 20 mm = 020.
 l₁ = 120 mm = 120
 Order No = 2024.94.020.120

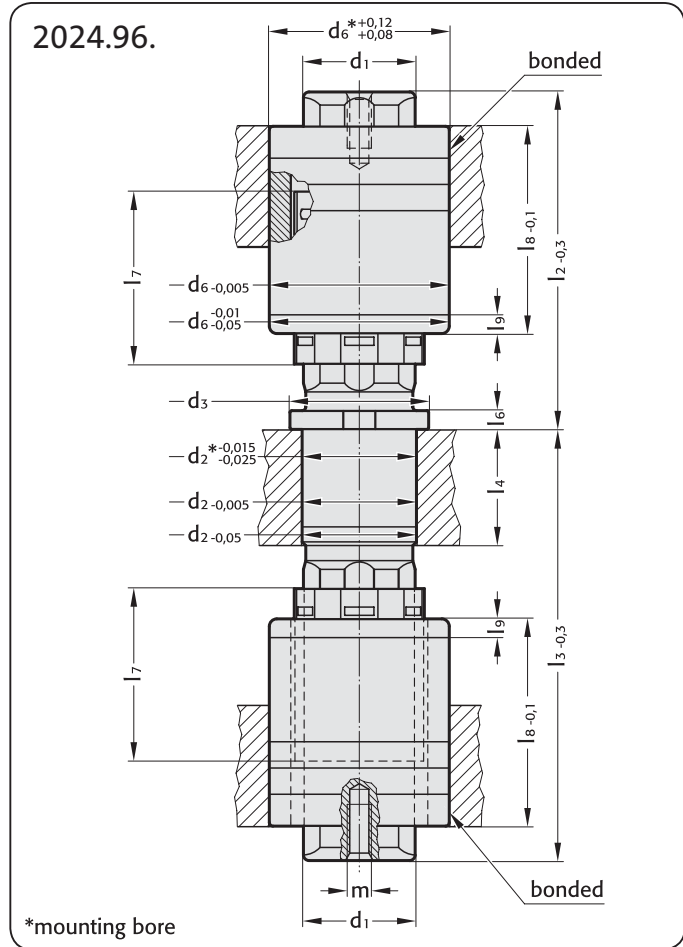

Cross section of guide unit

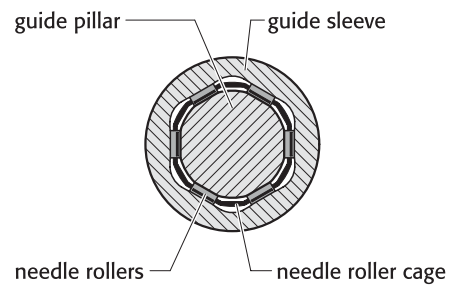

- Ø 16 4 Running surfaces
- Ø 12, Ø 20 - Ø 30 6 Running surfaces

The secret of the high rigidity, robustness and guide accuracy of FIBRO Million Guide guide units is the large surface area of the needle rollers.

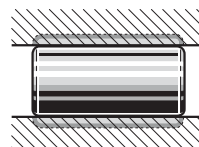

FIBRO

2024.96.

Million Guide - Guide Units

Description:

FIBRO Million Guide guide units are used wherever rigidity, robustness and a precision guide function is required. For stroke speeds up to 50 m/min and temperatures up to 80 °C.

Version:

Guide unit consisting of a paired guide pillar & guide sleeves and needle roller cages.

Materials:

Needle roller cage: plastic
 Needle rollers: steel, hardened
 Guide sleeve: tool steel alloy, hardened, 60±2 HRC
 Guide pillar: tool steel alloy, hardened, 60±2 HRC
 Disk: Steel

Note:

Guide units must be installed in accordance with the Instructions.

2024.96.

d ₁	12	16	20	25	30
d ₂	12,5	16,5	20,5	25,5	30,5
d ₃	19	23	27	32	37
d ₆	22	28	34	40	48
m	M5x8	M6x10	M8x20	M8x20	M8x20
l ₄	12	16	20	25	30
l ₆	4	5	5	5	5
l ₇	29,8	30	46	56	68
l ₈	30	40	50	60	70
l ₉	–	–	20	20	20
	l ₂	l ₂	l ₂	l ₂	l ₂
l ₃ 50	40/50/60				
60	40/50/60				
70	40/50/60				
80	40/50/60/70				
90	50/60/70/80				
100	50/60/70/80				
110	60/70/80/90				
	60/70/80				
	60/70/80/90				
	70/80/90				

Ordering Code (example):

Million Guide – guide unit
 with centre fixing = 2024.96.

d₁ = 20 mm = 020.

l₃ = 80 mm = 080.

l₂ = 70 mm = 070

Order No = 2024.96.020.080.070

Rectangular Mounting Flanges
Bronze with Non-Liquid Lubricant

2031.70.



2031.70.

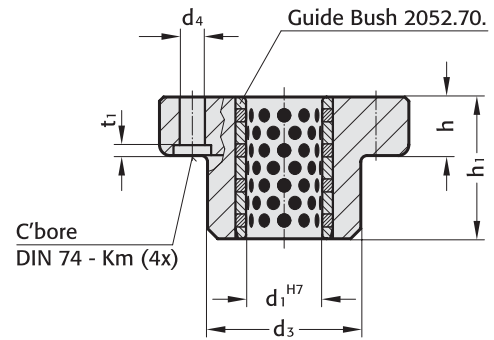

Mounting examples:

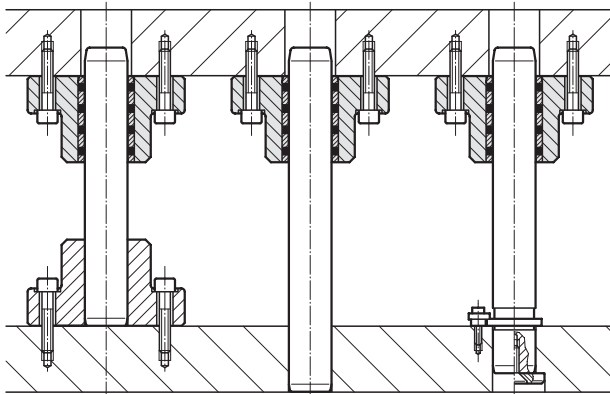

Guide pillars
* 202.19. * 202.19.
 * 2022.19. * 2022.19.
 * 2022.25. * 2022.25.
 * 2021.46. * 2021.46.
 2021.43. 2021.43.

* Guide pillars, to order separately, see pages D16, D26, D31, and D35.

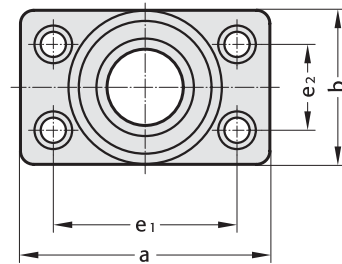

Material:

Mounting flange – special cast iron
Guide bush 2052.70.
Bronze, with non-liquid lubricant.

Execution:

Face and top machined.

2031.70.

d ₁	19	20	24	25	30	32	38	40	50	63	80
d ₃	45	45	50	50	65	65	80	80	96	110	130
d ₄	9	9	9	9	11	11	14	14	18	18	22
a	85	85	90	90	115	115	130	130	160	180	215
b	45	45	50	50	65	65	80	80	96	110	130
e ₁	64	64	68	68	83	83	95	95	118	132	160
e ₂	24	24	28	28	34	34	45	45	55	62	75
h	18	18	22	22	25	25	30	30	35	35	40
h ₁	37	37	47	47	60	60	77	77	95	120	120
t ₁	3	3	3	3	3	3	3	3	4	4	10

Ordering Code (example):

Mounting Flange, Guide Bush
with Non-Liquid Lubricant 2052.70. = 2031.70.

d₁ = 40 mm = 040

Order No = 2031.70.040

FIBRO

2031.01./31./41.
206.71.

Rectangular Mounting Flanges – without screw holes – Ball Cages

2031.31.

Mounting Flange with Sintered Ferrite Guide Bush, carbonitrided

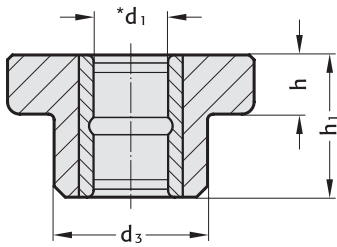

2031.41.

Mounting Flange with Ball Bearing Guide Bush

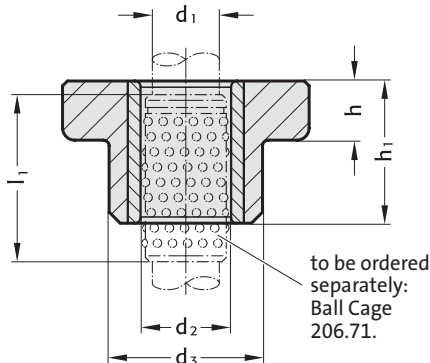

2031.01.

Mounting Flange for Guide Pillars

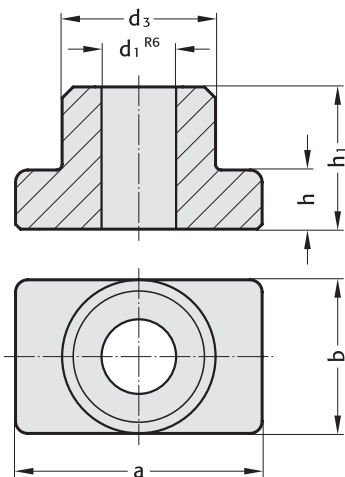

*Colour Code Combinations/Clearances – see pages D10 and D11.



Mounting Examples:

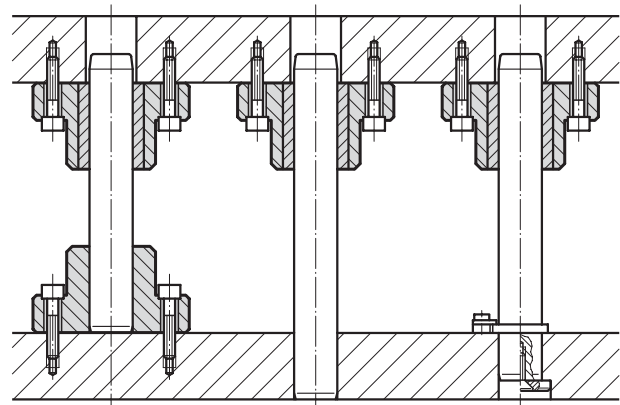

Guide Pillars
*202.19.

*202.19.

*2021.46.
*2021.43.

*Guide Pillars, to order separate, see pages D16 and D35.

2031.01./2031.31./2031.41.

d ₁	15	16	19	20	24	25	30	32	38	40	48	50	60	63	80
d ₂	21	22	25	26	30	31	38	40	46	48	56	58	68	71	–
d ₃	35	45	50	50	65	65	80	80	96	96	110	110	130	130	–
a	70	85	90	90	115	115	130	130	160	160	180	180	215	215	–
b	35	45	50	50	65	65	80	80	96	96	110	110	130	130	–
h	18	18	22	22	25	25	30	30	35	35	35	35	40	40	–
h ₁	30	37	47	47	60	60	77	77	95	95	120	120	120	120	–
l*	45	45	56	56	71	71	95	95	120	120	140	140	–	–	–
l ₁ *	44	44	56	56	70	70	95	95	120	120	140	140	–	–	–

Tolerance range – yellow = .10

green = .20

l* = Nominal ordering length

l₁* = Manufacturing length = Preferred lengths of Ball Cages

red = .30

Ordering Code (example):

Mounting Flange with sintered ferrite guide bush	= 2031.31.	Ball Cage	= 206.71.	Mounting flange for Guide Pillars	= 2031.01.
d ₁ = 32 mm	= 032.	d ₁ = 32 mm	= 032.	d ₁ = 40 mm	= 040
Tolerance range – red	= 30	l = 71 mm	= 071		
Order No	= 2031.31.032.30	Order No	= 206.71.032.071	Order No	= 2031.01.040

Material:

Special cast iron

Execution:

Mounting Flanges for Guide Bushes:
Face and top machined.
Bores honed.

Mounting Flanges for Guide Pillars:
Face and top machined.
Hole fine bored to d₁^{R6} fit.

Note:

Check squareness of pillars after press-fitting.

Notes on Sliding-/Ball Bearing Guides – see page D9.

Rectangular Mounting Flanges Ball Cages

2031.02./34./42.
206.71.



2031.34.

Mounting Flange with Sintered Ferrite Guide Bush, carbonitrided

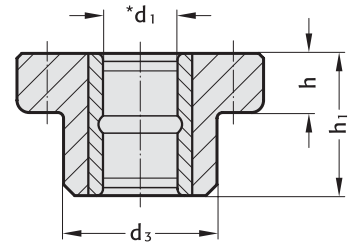

2031.42.

Mounting Flange for Ball Bearing Guide

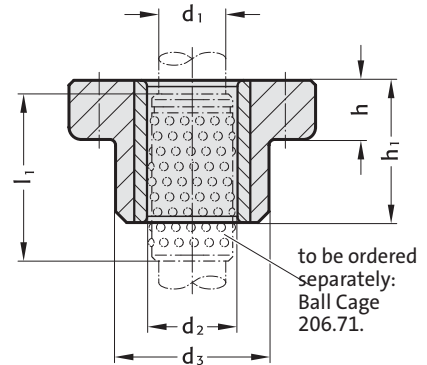

Mounting Examples:

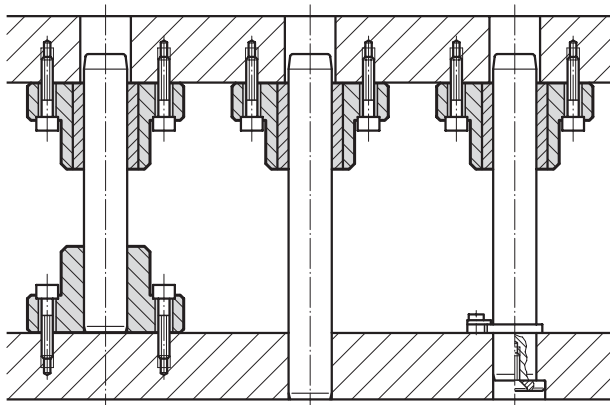

Guide Pillars *202.19. *202.19. *2021.46. 2021.43.

*Guide Pillars, to order separate, see pages D16 and D35.

2031.02.

Mounting Flange for Guide Pillars

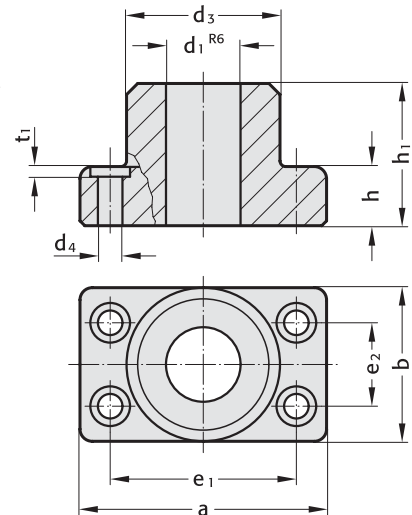

*Colour Code Combinations/Clearances – see pages D10 and D11.

Material:

Special cast iron

Execution:

Mounting Flanges for Guide Bushes:
Face and top machined.
Bores honed.

Mounting Flanges for Guide Pillars:
Face and top machined.
Hole fine bored to d_1^{R6} – fit.

Note:

Check squareness of pillars after press-fitting.

Notes on Sliding-/Ball Bearing Guides – see page D9.

2031.02./2031.34./2031.42.

d_1	15	16	19	20	24	25	30	32	38	40	48	50	60	63	80
d_2	21	22	25	26	30	31	38	40	46	48	56	58	68	71	–
d_3	35	–	45	–	50	–	65	–	80	–	96	–	110	–	130
d_4	6,6	–	9	–	9	–	11	–	14	–	18	–	18	–	22
t_1	3	–	3	–	3	–	3	–	3	–	4	–	4	–	10
a	70	–	85	–	90	–	115	–	130	–	160	–	180	–	215
b	35	–	45	–	50	–	65	–	80	–	96	–	110	–	130
e_1	53	–	64	–	68	–	83	–	95	–	118	–	132	–	160
e_2	19	–	24	–	28	–	34	–	45	–	55	–	62	–	75
h	18	–	18	–	22	–	25	–	30	–	35	–	35	–	40
h_1	30	–	37	–	47	–	60	–	77	–	95	–	120	–	120
l^*	45	–	45	–	56	–	71	–	95	–	120	–	140	–	–
l_1^*	44	–	44	–	56	–	70	–	95	–	120	–	140	–	–

Tolerance range – yellow = .10
green = .20
red = .30

l^* = Nominal ordering length

l_1^* = Manufacturing length = Preferred lengths of Ball Cages

Ordering code (example):

Mounting Flange for Ball Bearing Guide	= 2031.42.	Ball Cage	= 206.71.	Mounting flange for Guide Pillars	= 2031.02.
$d_1 = 40$ mm	= 040.	$d_1 = 40$ mm	= 040.	$d_1 = 40$ mm	= 040
Tolerance range – green	= 20	$l = 95$ mm	= 095		
Order No	= 2031.42.040.20	Order No	= 206.71.040.095	Order No	= 2031.02.040

FIBRO

2031.04./38./44.
206.71.

Shallow Mounting Flanges – Rectangular – Ball Cages

2031.38.

Mounting Flange
with Sintered
Ferrite Guide Bush,
carbonitrided

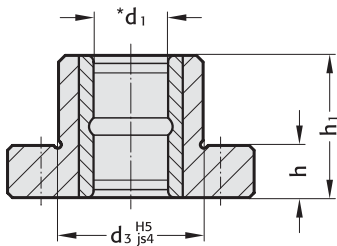

2031.44.

Mounting
Flange for
Ball Bearing
Guide

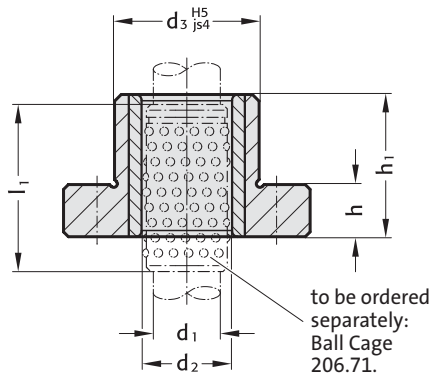

2031.04.

Mounting
Flange for
Guide Pillars

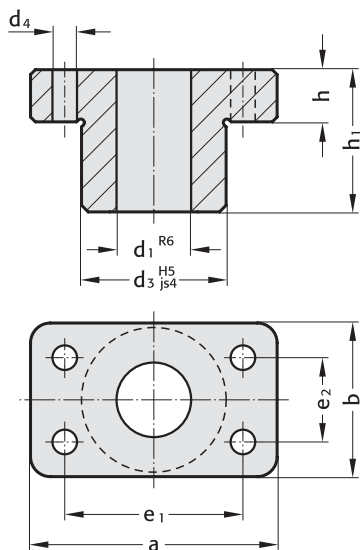

*Colour Code Combinations/Clearances – see pages D10 and D11.



Mounting Examples:

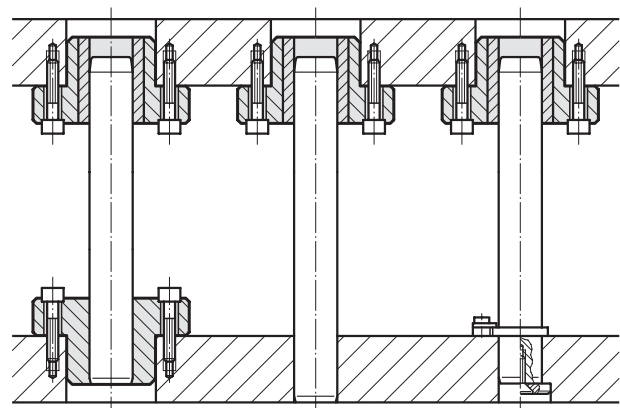

Guide Pillars
*202.19.

*202.19.

*2021.46.
2021.43.

*Guide Pillars, to order separate, see pages D16 and D35.

2031.04./2031.38./2031.44.

d ₁	15	16	19	20	24	25	30	32	38	40	48	50	60	63	80
d ₂	–	–	25	26	30	31	38	40	46	48	56	58	–	–	–
d ₃	32	–	42	–	47	–	62	–	77	–	93	–	107	–	127
d ₄	7	–	9	–	9	–	11	–	14	–	18	–	18	–	22
a	70	–	85	–	90	–	115	–	130	–	160	–	180	–	215
b	35	–	45	–	50	–	65	–	80	–	96	–	110	–	130
e ₁	53	–	64	–	68	–	83	–	95	–	118	–	132	–	160
e ₂	19	–	24	–	28	–	34	–	45	–	55	–	62	–	75
h	16	–	16	–	20	–	23	–	28	–	33	–	33	–	38
h ₁	30	–	37	–	47	–	60	–	77	–	95	–	120	–	120
l*	–	–	45	–	56	–	71	–	95	–	120	–	–	–	–
l ₁ *	–	–	44	–	56	–	70	–	95	–	120	–	–	–	–

Tolerance range – yellow = .10

green = .20

red = .30

l* = Nominal ordering length

l₁* = Manufacturing length = Preferred lengths of Ball Cages

Ordering Code (example):

Mounting Flange for Ball Bearing Guide	= 2031.44.	Ball Cage	= 206.71.	Mounting flange for Guide Pillars	= 2031.04.
d ₁ = 40 mm	= 040.	d ₁ = 40 mm	= 040.	d ₁ = 40 mm	= 040
Tolerance range – yellow	= 10	l = 95 mm	= 095		
Order No	= 2031.44.040.10	Order No	= 206.71.040.095	Order No	= 2031.04.040

Material:

Special cast iron

Execution:

Both faces machined to dims. h;
O. D. d₃ turned.

Mounting Flange for Guide Bushes:
Bores honed.

Mounting Flanges for Guide Pillars:
Hole fine bored to d₁^{R6} – fit.

Note:

Check squareness of pillars
after press-fitting.

Notes on Sliding-/Ball Bearing Guides –
see page D9.

**Rectangular Mounting Flanges
Bronze with Non-Liquid Lubricant**

**2032.70.
2032.02.**

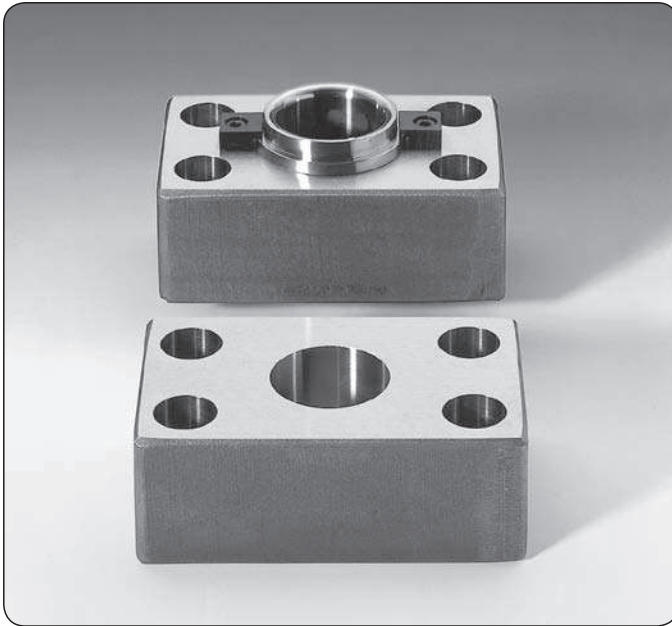

2032.70.

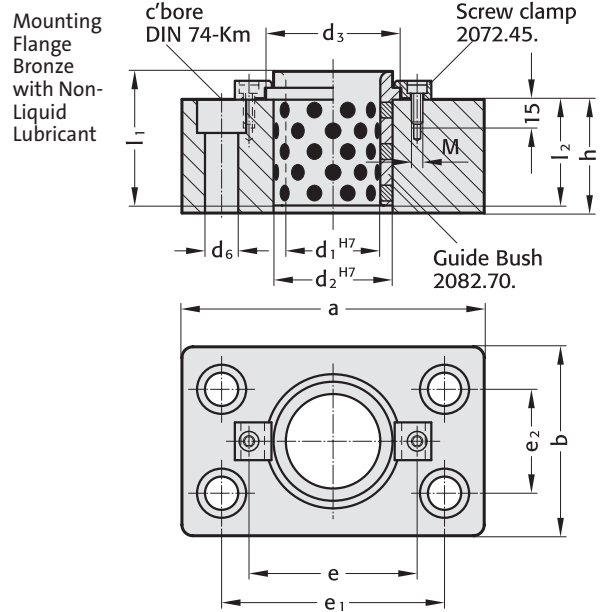

Mounting Examples:

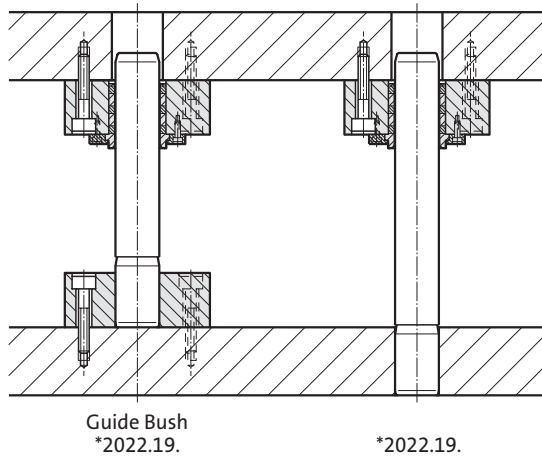

*Guide Pillars, to order separate, see page D31.

2032.02.

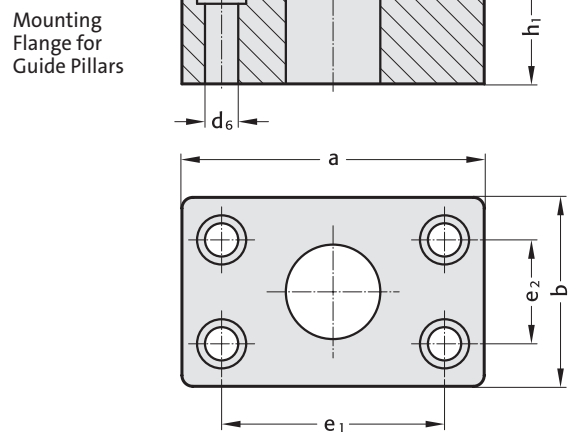

2032.02./2032.70

d ₁	50	63	80	100	125	160
d ₂	63	80	100	125	160	200
d ₃	71	90	112	140	180	220
d ₆	17,5	17,5	21,5	21,5	25,5	25,5
a	160	180	215	230	270	315
b	100	125	145	170	205	250
e	89	123	143	168	203	243
e ₁	118	132	160	168	203	243
e ₂	55	62	75	110	142	170
h	60	70	90	110	140	180
h ₁	70	80	100	125	140	180
l ₁	71	80	100	125	160	200
l ₂	56	63	80	106	132	170
M	M6 x 16	M10 x 16	M10 x 16	M10 x 16	M10 x 16	M10 x 16

Ordering Code (example):

Mounting Flange, Bronze with Non-Liquid Lubricant = 2032.70.
 d₁ = 50 mm = 050
 Order No = 2032.70.050

Material:

St 37.

Execution:

Mounting Flange Bronze with Non-Liquid Lubricant: Face and top machined.
 Guide Bush 2082.70. Bronze with Non-Liquid Lubricant, oilless lubricating.

Mounting Flange for Guide Pillars: Face and top machined.
 Hole fine bored to d₁^{H7} – fit.

Note:

Check squareness of pillars after press-fitting.

A large, empty rectangular box with rounded corners, occupying most of the page. It is intended for drawing or writing.

Guide Bushes DIN 9831/ISO 9448-2
Sintered Ferrite, carbonitrided,
long-term lubrication

FIBRO

2051.32.



2051.32.

for slip-fit
bonding

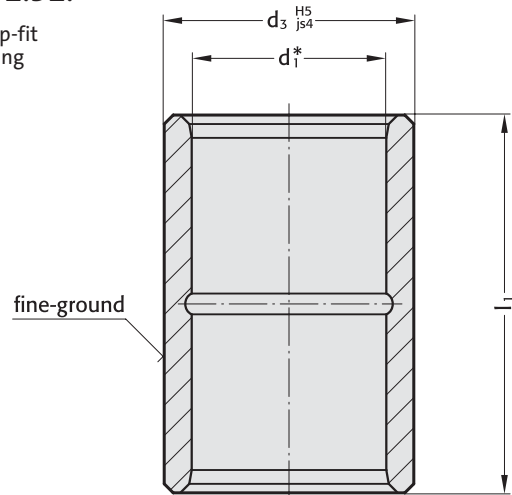

* Colour Code Combinations/Clearances – see pages D10 and D11.

Material:

Sintered ferrite of high purity, carbonitrided

Execution:

Bearing surfaces and outside diameter fine-ground.

Slip-Fit Bonding:

The position of the bearing is given by push fit holes tolerance H5. The adhesive (order no. 281.648) provides optimum push retention whilst offering the following advantages:

- high accuracy and stiffness
- no problems to find position when changing bushings

We do not recommend to press fit for the same reasons mentioned above.

Note:

Notes on Sliding- and Ball Bearings Guides: see page D9.

Pillars see pages D14, D16, D17, D18, D22 and D35.

Tolerance range – yellow = .10
green = .20
red = .30

Ordering Code (example):

Guide Bush DIN 9831/ISO 9448-2	=	2051.32.
d ₃ = 40 mm	=	040.
l ₁ = 60 mm	=	060.
Tolerance range – red	=	30
Order No	=	2051.32.040.060.30

2051.32.

d ₃	8	11	12	15	16	19	20	24	25	30	32	38	40	48	50	60	63	80
d ₃	13,7	22		28		32		40		48		58		70		85		95,7
l ₁	15	●																
23		●		●		●		●										
30		●		●		●		●		●		●						
37		●		●		●		●		●		●		●				
47				●		●		●		●		●		●				
60		∅8–∅12 not available in Tolerance range red = .30		●		●		●		●		●		●		●		●
77						●		●		●		●		●		●		●
95										●		●		●		●		
110																		●
120														●		●		●

Special Ball Bearing Cages – Brass Made to Customers' Specifications

For use in special machine tools, general purpose machines, jigs and fixtures etc. brass ball cages are made to customers' specifications – without limitations to length and ball pattern.



Loading Diagram for Ball Bearing Guides

Bearing Life versus Loading:

Values shown are based on the Impact Factor of $f_s = 1$ which is applicable to normal conditions in respect of die set and press, with a maximum bearing temperature of 100 °C.

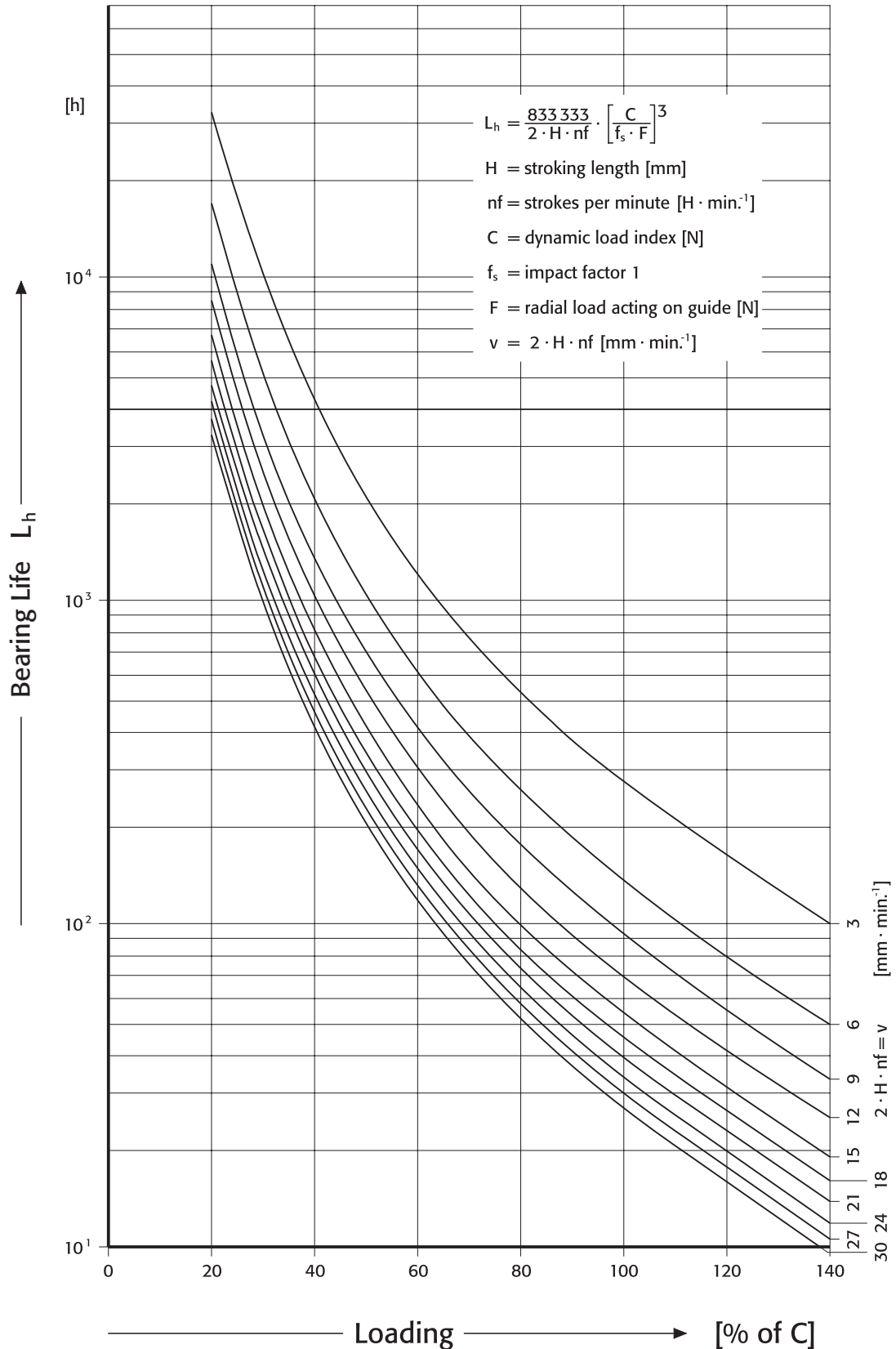

Safe Loads for FIBRO Ball Bearing Guides

Tables of Dynamic Load Indexes

Definition:

The dynamic load index C constitutes a constant loading that will allow the respective sizes of ball bearing guides to reach + 105 m without any discernible bearing damage. The load index is shown in N and results from tests executed with batches of sufficient size, subjected to linear travel oscillations and radially imposed loads of constant magnitude and unchanging direction.

Pillar $\varnothing d_1$	Cage length l_1	Dynamic Load Index C for whole cage (N)	Pillar $\varnothing d_1$	Cage length l_1	Dynamic Load Index C for whole cage (N)
8	40	450	38	45	7500
10	40	1630		50	8200
	56	2210		56	8900
11	40	1660		63	10300
	56	2250		80	12100
12	40	1680		95	13900
	56	2280		105	15000
15	45	3300		120	16700
	56	4050		140	18700
	63	4550		160	20700
	71	4950		180	22600
16	24	1910		200	24400
	28	2230		240	28000
	45	3350	40	45	7500
	56	4100		50	8200
	63	4600		56	9000
	71	5000		63	10300
19	31	3050		80	12200
	45	4050		95	14000
	56	4950		105	15100
	71	6100		120	16700
	80	6600		140	18800
	95	7600		160	20800
20	24	2320		180	22700
	28	2700		200	24600
	31	3100		240	28000
	45	4100	48	50	9400
	56	5000		63	11700
	71	6100		80	13800
	80	6600		95	15900
	95	7600		105	17100
24	31	3150		120	19000
	40	3850		140	21400
	45	4200		160	23600
	56	5100		180	26000
	71	6300		200	28000
	80	6800		240	32000
	95	7800	50	50	9400
	120	9300		63	11700
25	31	3200		80	13900
	40	3900		95	15900
	45	4200		105	17200
	56	5200		120	19100
	71	6300		140	21400
	80	6900		160	23700
	95	7900		180	26000
	120	9300		200	28000
30	40	5700		240	32000
	45	6400	60	95	17700
	50	7000		105	19200
	56	7600		120	21300
	71	9300		140	23900
	75	9800		160	26500
	80	10400		180	29000
	95	11900		200	31000
	105	12800		240	35500
	120	14200	63	95	17800
	140	16000		105	19300
	160	17700		120	21300
32	40	5800		140	24000
	45	6400		160	26500
	50	7100		180	29000
	56	7700		200	31500
	71	9400		240	35500
	75	9900	80	120	41000
	80	10500		140	46500
	95	12000		160	52000
	105	12900		180	57000
	120	14300		200	62000
	140	16100		240	70000
	160	17800			

Ball Bearing Guide Bushes DIN 9831/ISO 9448-3 Ball Cages

FIBRO
2061.44.
206.71.



2061.44.

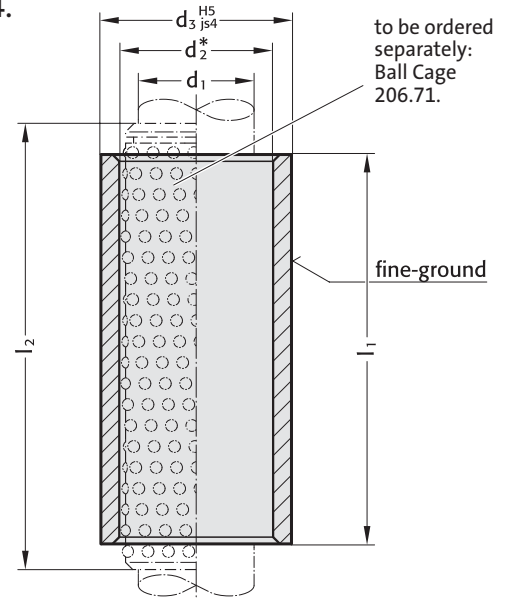

Material:

Bush: tool steel, Hardness: 62 ± 2HRC
Cage: brass
Balls: hardened steel (DIN 5401)

Execution:

Bearing surfaces honed.
Outside diameter fine-ground.

Slip-Fit Bonding:

The position of the bearing is given by push fit holes tolerance H5. The adhesive (order no. 281.648) provides optimum push retention whilst offering the following advantages:

- high accuracy and stiffness
- no problems to find position when changing bushings

We do not recommend to press fit for the same reasons mentioned above.

Note:

Notes on sliding- and rolling type guides see page D9.
Pillars see pages D14, D16, D17, D18, D22 and D35.

* Preloading see Colour Code Combinations – pages D10 and D11.

* Ball cages Ø8 supplied without fastening ring groove and assembly aid!

Note: cage travel = one half of stroke length

l* = Nominal ordering length

l2* = Manufacturing length = Preferred lengths of Ball Cages

Ordering Code (example):

Ball Cage	=	206.71.
d ₁ = 30 mm	=	030.
l ₂ = 120 mm	=	120
Order No	=	206.71.030.120

Tolerance range – yellow = .10
green = .20
red = .30

Ordering Code (example):

Guide Bush	=	2061.44.
d ₁ = 30 mm	=	030.
l ₁ = 95 mm	=	095.
Tolerance range – yellow	=	10
Order No	=	2061.44.030.095.10

2061.44.

d ₁	8*	10	11	12	15	16	19	20	24	25	30	32	38	40	48	50	60	63	80					
d ₂	11	14	15	16	21	22	25	26	30	31	38	40	46	48	56	58	68	71	92					
d ₃	18	22	22	22	28	28	32	32	40	40	48	48	58	58	70	70	85	85	105					
l ₁	l*	l ₂ *																						
23	40	39	●	●	●																			
23	45	44				●	●	●	●	●	●													
30	40	39	●	●	●	●																		
30	45	44				●	●	●	●	●	●													
30	45	45										●	●	●	●									
37	40	39	●	●	●																			
37	45	44				●	●	●	●	●	●													
37	50	50	Diameter 8–12 not available in Tolerance range red = .30									●	●	●	●	●	●							
47	56	55										●	●											
47	56	56										●	●	●	●	●	●	●						
47	63	55																●	●	●	●			
60	71	70										●	●											
60	71	72				●	●	●	●	●	●													
60	80	80										●	●	●	●									
60	95	95																●	●					
77	95	95										●	●	●	●	●	●	●	●	●	●			
77	95	96				●	●	●	●	●	●	●	●	●	●	●	●	●	●	●				
95	120	120										●	●	●	●	●	●	●	●	●				
120	140	140										●	●	●	●	●	●	●	●	●	●			

FIBRO

206.49.
206.71.

Ball Bearing Guide Bushes similar to AFNOR Ball Cages

206.49.

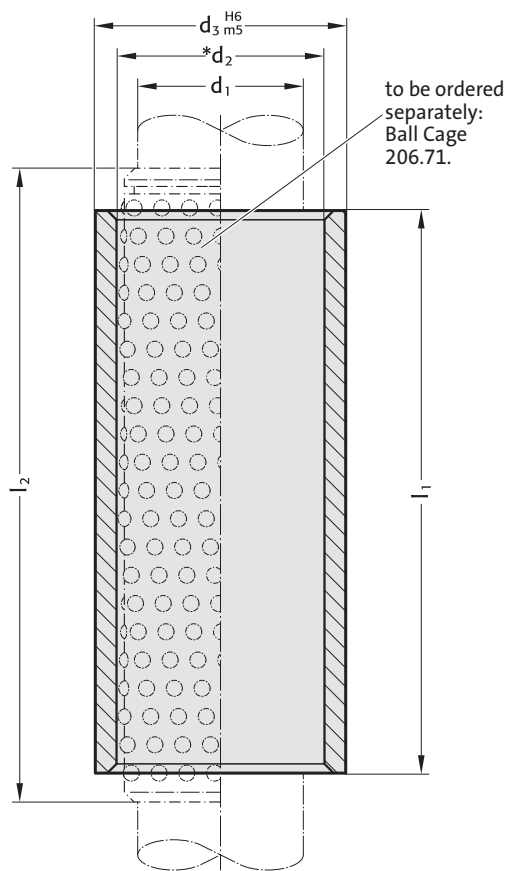

* Preloading see Colour Code Combinations – pages D 10 and D 11.

Tolerance range – yellow = .10
green = .20
red = .30

Ordering Code (example):

Guide Bush	=	206.49.
$d_1 = 32$ mm	=	032.
$l_1 = 90$ mm	=	090.
Tolerance range green	=	20
Order No	=	206.49.032.090.20

Mounting Examples

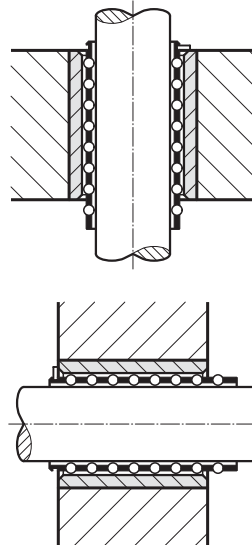

Material:

Bush: tool steel, Hardness: 62 ± 2 HRC
Cage: brass
Balls: hardened steel (DIN 5401)

Execution:

Bearing surfaces honed.
Outside diameter fine-ground.

Note:

Notes on sliding- and rolling type guides see page D9.
Pillars see pages D16, D17, D18, D22 and D35.

Slip-Fit Bonding:

The position of the bearing is given by push fit holes tolerance H5. The adhesive (order no. 281.648) provides optimum push retention whilst offering the following advantages:

- high accuracy and stiffness
- no problems to find position when changing bushings

We do not recommend to press fit for the same reasons mentioned above.

206.49./206.71.

d_1		16	20	25	32	40	50	
d_2		22	26	31	40	48	58	
d_{3m5}		28	32	40	50	63	80	
l_1	l^*	l_2^*						
35	45	44	●	●				
40	45	44	●	●	●			
45	56	55				●		
50	56	56	●	●	●			
55	63	65					●	
60	71	70				●		
60	71	72	●	●	●			
70	80	80		●	●	●		
80	95	95				●	●	●
80	95	96		●	●			
90	95	96			●			
90	105	105				●	●	●
100	120	120				●	●	●
120	140	140					●	●

Ordering Code (example):

Ball Cage	=	206.71.
$d_1 = 32$ mm	=	032.
$l_2 = 105$ mm	=	105
Order No	=	206.71.032.105

Note: cage travel = one half of stroke length

l^* = Nominal ordering length

l_2^* = Manufacturing length = Preferred lengths of Ball Cages

**Ball Cages with Circlip Groove
Circlips**

**206.71.
206.72.**

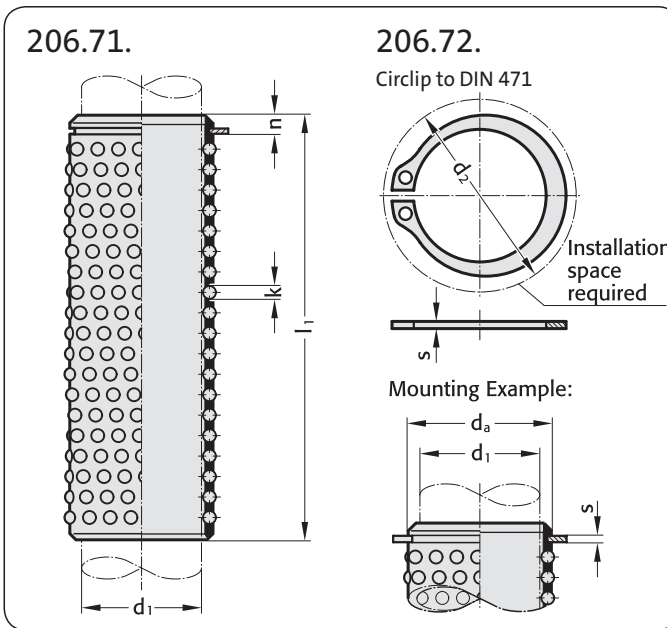

Material:
Cage: Brass
Balls: hardened steel (DIN 5401)

Execution:
FIBRO Ball Cages are made from brass. They are distinguished by their stability and dense ball pattern. This makes them the preferred choice in tools and machines of high precision demands and elevated stroking speeds. Ball guides operate free from play because of their accurate preloading.

Each ball cage has a groove for circlip to DIN 471.

206.72.

Order No	010	011	012	015	016	018	019	020	024	025	030	032	038	040	042	048	050	052	060	063	080
d ₁	10	11	12	15	16	18	19	20	24	25	30	32	38	40	42	48	50	52	60	63	80
d _a × s	13×1	14×1	15×1	20×1,2	21×1,2	23×1,2	24×1,2	25×1,2	29×1,5	30×1,5	37×1,75	39×1,75	45×1,75	47×1,75	48×1,75	55×2	57×2	58×2	67×2,5	70×2,5	90×3
d ₂	20,2	21,4	22,6	28,4	29,6	32	33,2	34,2	39,1	40,5	49	51,4	59,1	60,8	62,5	70,2	72,6	73,6	83,1	87	108,5

206.71.

d ₁	8*	10	11	12	15	16	19	20	24	25	30	32	38	40	48	50	60	63	80		
k	1,5	2	2	2	3	3	3	3	3	3	4	4	4	4	4	4	4	4	6		
n	-	2,2	2,2	2,2	2,9	2,9	2,9	2,9	3,2	3,95	3,95	3,95	4,25	4,75	6,15						
l*	l ₁ *	total number of balls																			
24	24						64		80												
28	28						80		100												
31	32							120	120		120										
40	39	80	176	176	176																
40	40										160	120									
45	44					144	144	180	180	180											
45	45											140	168								
50	50											160	192	224							
56	55											180	216								
56	56					192	192	240	240	240											
56	57	272	272	272																	
63	64					224	224														
63	65													264	308						
71	70											240									
71	72				256	256	320	320	320												
80	80						360	360	360		280	336	392								
95	95										340	408	476	544							
95	96						440	440	440												
105	105											380	456	532	608						
120	119																				540
120	120										560	440	528	616	704						
140	140											520	624	728	832	648					
160	160											600	720	840	960						
160	161																				756
180	180													816	952	1088					
180	182																				864
200	200													912	1064	1216					
200	203																				972
240	238																				1152
240	240														1104	1288	1472				

Note: cage travel = one half of stroke length * Ball cages Ø8 supplied without circlip groove !
l* = Nominal ordering length l₁* = Manufacturing length

FIBRO

206.73.

Ball Cages with Assembly Aid

Material:

Cage: Brass
 Balls: hardened steel
 (DIN 5401)

206.73.

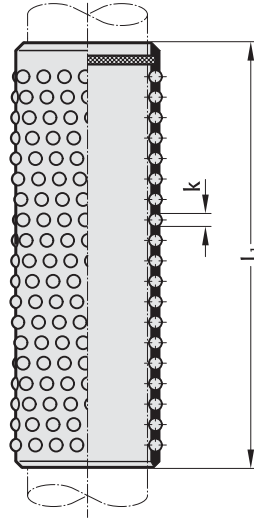

Execution:

FIBRO Ball Cages are made from brass. They are distinguished by their stability and dense ball pattern. This makes them the preferred choice in tools and machines of high precision demands and elevated stroking speeds. Ball guides operate free from play because of their accurate preloading.

Note:

Ball cages 206.73. with cage spacing.

These cages are held at the correct height for engaging the top die. These cages are equipped with a suitably positioned brake ring insert – ensuring equal cage spacing especially on die sets with multiple pillars. No assistant is needed for their assembly.

206.73.

d_1	10	11	12	15	16	19	20	24	25	30	32	38	40	48	50	60	63	80	
k	2	2	2	3	3	3	3	3	3	4	4	4	4	4	4	4	4	6	
l^*	l_1^*	total number of balls																	
24	24						64												80
28	28						80												100
31	32																		120
40	39	176	176	176															120
40	40																		160
45	44																		120
45	45						144	144	180	180	180								180
50	50																		140
56	55																		168
56	56																		192
56	57	272	272	272															224
63	64																		180
63	65																		216
71	70																		180
71	72																		240
80	80																		240
95	95																		240
95	96																		240
105	105																		240
120	119																		240
120	120																		240
140	140																		240
160	160																		240
160	161																		240
180	180																		240
180	182																		240
200	200																		240
200	203																		240
240	238																		240
240	240																		240

Ordering Code (example):

Ball Cage with Assembly Aid = 206.73.
 $d_1 = 32$ mm = 032.
 $l_1 = 80$ mm = 080
 Order No = 206.73.032.080

Note: cage travel = one half of stroke length

l^* = Nominal ordering length

l_1^* = Manufacturing length

FIBRO

2061.47.
206.71.

Ball Bearing Guide Bushes with stroke Limitation Ball Cages

2061.47.

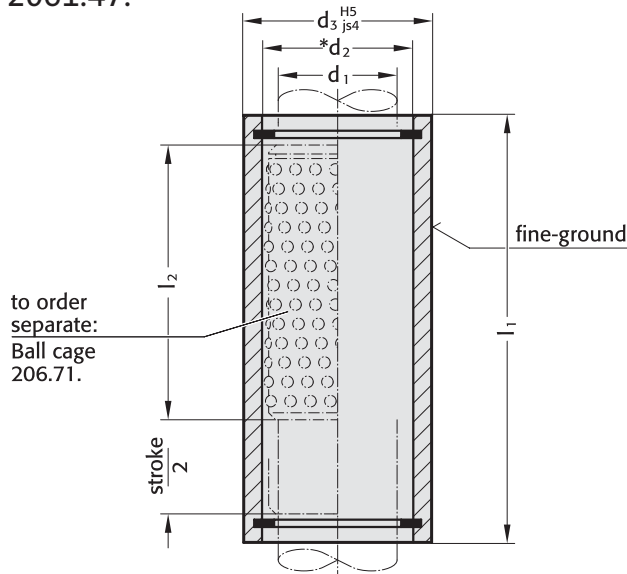

* Preloading see Colour Code Combinations – pages D10 and D11.

Ordering Code (example):

Ball cage	=	206.71.
$d_1 = 40$ mm	=	040.
$l = 63$ mm	=	063
Order No	=	206.71.040.063

Tolerance range – yellow = .10
green = .20
red = .30

Ordering Code (example):

Guide Bush	=	2061.47.
$d_1 = 40$ mm	=	040.
$l_1 = 120$ mm	=	120.
Tolerance range – red	=	30
Order No	=	2061.47.040.120.30



Material:

Bush: tool steel, Hardness: 62±2HRC
Cage: Brass
Balls: hardened steel (DIN 5401)

Slip-Fit Bonding:

The position of the bearing is given by push fit holes tolerance H5. The adhesive order no. 281.648 provides optimum push retention whilst offering the following advantages:

- high accuracy and stiffness
- no problems to find position when changing bushings

We do not recommend to press fir for the same reasons mentioned above.

Note:

Notes on sliding- and rolling type guides see page D9.
Pillars see pages D16, D17, D18, D22 and D35.

2061.47.

	d_1	15	16	19	20	24	25	30	32	38	40	48	50	60	63
	d_2	21	22	25	26	30	31	38	40	46	48	56	58	68	71
	d_3	28	28	32	32	40	40	48	48	58	58	70	70	85	85
l_2^*	l^*	Stroke max.	l_1												
44	45	18	60	●	●										
44	45	52	77		●	●									
44	45	49					●	●							
56	56	27				●	●								
50	50	74	95					●	●						
70	71	32						●	●						
65	63	98	120							●	●				
80	80	64								●	●				
105	105	14								●	●				
80	80	62										●	●		
95	95	32												●	●

Note: cage travel = one half of stroke length

l^* = Nominal ordering length

l_2^* = Manufacturing length = Preferred lengths of Ball Cages

Headed Guide Bushes for Ball Bearings

2081.67.



2081.67.

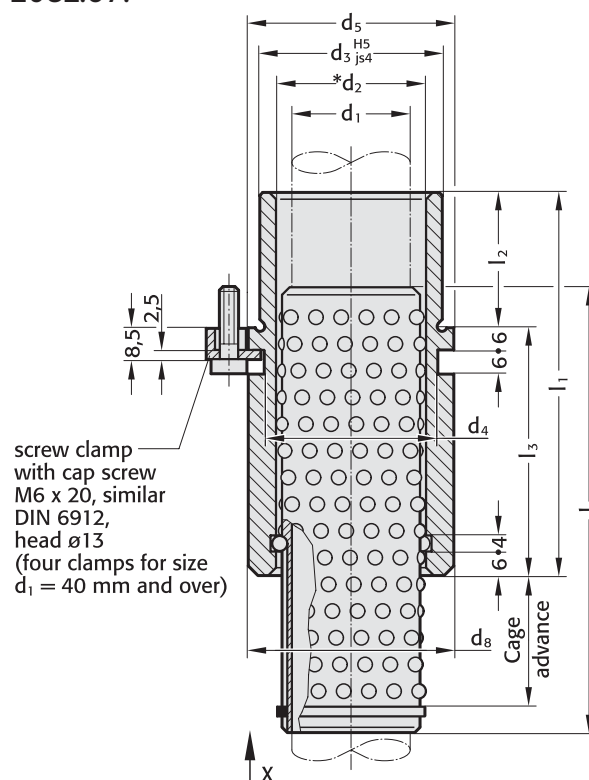

screw clamp with cap screw M6 x 20, similar DIN 6912, head ø13 (four clamps for size d₁ = 40 mm and over)

207.45

Order No. for repeat order

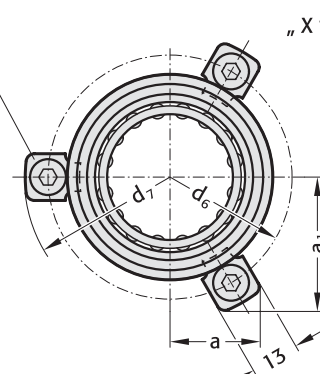

* Preloading see Colour Code Combinations – pages D10 and D11.

Note:

Ball cage position – please specify the required cage advance with order.

FIBRO Ball Cage Retainers ensure optimum starting position of ball cages on inverted die sets – even if pillars retract from guide bushes. The application determines the cage advance. Note that cage travel is half the stroke length.

In this context it is of importance to note the minimum constructional length.

The cage advance should be chosen so that during normal operation of the tool, optimum position is achieved.

Material:

Bush: tool steel Cage: Brass
Hardness: 62±2 HRC Balls: hardened steel (DIN 5401)

2081.67.

d ₁	19 20	24 25	30 32	38 40	48 50	60 63
d ₂	25 26	30 31	38 40	46 48	56 58	68 71
d ₃	32	40	48	58	70	85
d ₄	32	40	48	58	70	85
d ₅	40	48	56	66	80	95
d ₆	52	60	67	77	91	106
d ₇	64,7	72,7	79,7	89,7	103,7	118,7
d ₈	39	46	53	63	77	92
a	20,7	22,65	24,4	35,3	40,2	45,5
a ₁	30	33,4	36,4	35,3	40,2	45,5
l ₁	59	79	93	108	127	150
l ₂	23	23	30	37	47	60
l ₃	36	56	63	71	80	90
l	72	96	120	140	140	160

Price and delivery on request!

Ordering Code (example):

Headed Guide Bush	=	2081.67.	
d ₁ = 50 mm	=	050.	Tolerance range – yellow = .10
cage advance 50 mm	=	050.	green = .20
Tolerance range – green	=	20	red = .30
Order No	=	2081.67.050.050.20	

Flanged Guide Bushes for Ball Bearings with Ball Cage Retainer

2091.67.

2091.67.

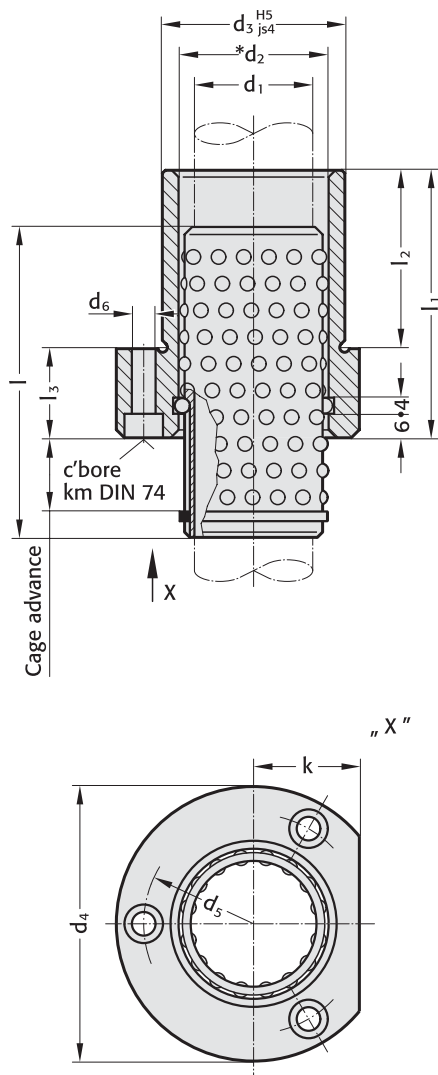

* Preloading see Colour Code Combinations – pages D 10 and D 11.



Note:

Ball cage position – please specify the required cage advance with order.

FIBRO Ball Cage Retainers ensure optimum starting position of ball cages on inverted die sets – even if pillars retract from guide bushes. The application determines the cage advance. Note that cage travel is half the stroke length.

In this context it is of importance to note the minimum constructional length.

The cage advance should be chosen so that during normal operation of the tool, optimum position is achieved.

Material:

Bush: tool steel, Hardness: 62±2HRC

Cage: Brass

Balls: hardened steel (DIN 5401)

2091.67.

d ₁	19 20	24 25	30 32	38 40	48 50	60 63	80
d ₂	25 26	30 31	38 40	46 48	56 58	68 71	92
d ₃	32	40	48	58	70	85	105
d ₄	50	63	72	85	104	120	148
d ₅	40	50	58	70	86	100	125
d ₆	4,5	5,5	5,5	6,6	9	9	11
Counterbore	Km 4	Km 5	Km 5	Km 6	Km 8	Km 8	Km 10
k	18	23	28	33	38	46	56
l ₁	52	62	72	77	102	102	125
l ₂	37	37	47	47	60	60	75
l ₃	15	25	25	30	42	42	50
l	72	72	80	95	105	120	140

Price and delivery on request!

Ordering Code (example):

Flanged Guide Bush with Ball Cage Retainer = 2091.67.

d₁ = 50 mm = 050. Tolerance range – yellow = .10

cage advance 50 mm = 050. green = .20

Tolerance range – green = 20 red = .30

Order No = 2091.67.050.050.20

Roller cages with Circlip Groove Circlips Roller Cages with Mounting Aid

FIBRO

2061.82. 206.72.
2061.84.



2061.82.

Roller Cage
with circlip
Groove

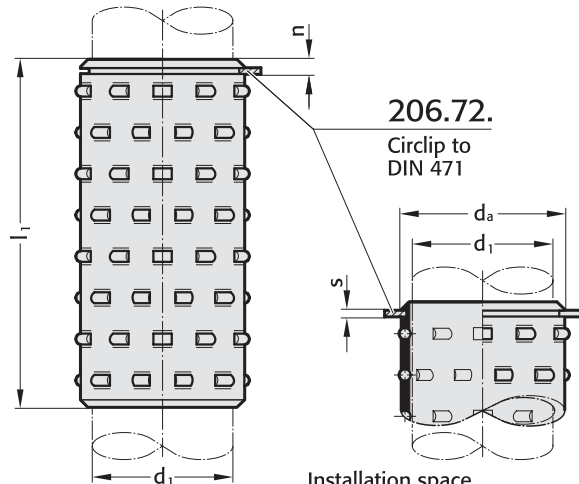

206.72.

Circlip to
DIN 471

Installation space
required

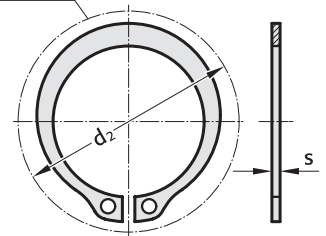
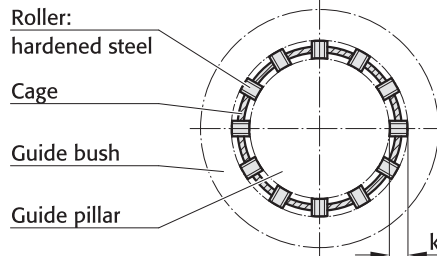

206.72.

Circlip to
DIN 471

2061.84.

Roller Cage
with Mounting
Aid

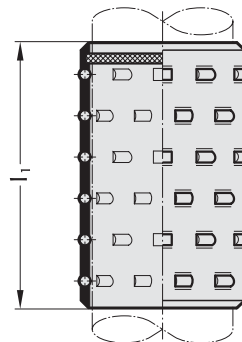

Description:

Roller cages make linear contact with the guide bush and the guide pillar.

This results in a load carrying capacity for each individual roller which is many times that of a ball of the same diameter.

Roller bearings feature a FIBRO specific seal, similar to the ball bearings.

The profile rollers are arranged in a spiral layout axially, so that every roller has its own path.

The cages are grooved to accept a DIN 471 circlip.

Note:

FIBRO-Roller Cage 2061.84. with Mounting Aid. This roller cage version can be inserted to the correct position without extra assistance. The cage has a braking ring insert in the holder. It is particularly advantageous in the case of die sets with multiple pillars.

Material:

Roller Cage: brass

Rollers: hardened steel,
100 Cr6, DIN 5402

Note:

Notes on sliding and rolling type guides see page D9.

Important:

For roller cages use only pairing class
guide pillar red = .30
Guide sleeve yellow = .10

Ordering Code (example):

Roller Cage with Circlip Groove	=	2061.82.
$d_1 = 25$ mm	=	025.
$l_1 = 85$ mm	=	085
Order No	=	2061.82.025.085

2061.82./2061.84.

	19	20	24	25	30	32	38	40	48	50	63
d_1	19	20	24	25	30	32	38	40	48	50	63
k	3	3	3	3	4	4	4	4	4	4	4
Number of rollers/peripheral row	8	10	12	14	14	18	18	22	22	22	22
n	2,9	3,2	3,95	3,95	3,95	3,95	4,25	4,25	4,75	4,75	4,75
l_1	total number of rollers										
45	32	40	48	48	—	—	—	—	—	—	—
55	40	50	60	60	70	—	—	—	—	—	—
65	48	60	72	72	84	108	—	—	—	—	—
75	56	70	84	84	98	126	154	—	—	—	—
85	64	80	96	96	112	144	176	—	—	—	—
95	72	90	108	108	126	162	198	—	—	—	—
105	80	100	120	120	140	180	220	—	—	—	—
115	—	110	132	132	154	198	242	—	—	—	—
125	—	120	144	144	168	216	264	—	—	—	—
135	—	—	156	156	182	234	286	—	—	—	—
145	—	—	168	168	196	252	308	—	—	—	—
155	—	—	180	180	210	270	330	—	—	—	—
165	—	—	192	192	224	288	352	—	—	—	—
175	—	—	—	—	238	306	374	—	—	—	—
185	—	—	—	—	252	324	396	—	—	—	—
205	—	—	—	—	—	280	360	440	—	—	—

206.72.

	19	20	24	25	30	32	38	40	48	50	63	
d_1	19	20	24	25	30	32	38	40	48	50	63	
$d_a \times s$	24x1,2	25x1,2	29x1,5	30x1,5	37x1,75	39x1,75	45x1,75	47x1,75	55x2	57x2	70x2,5	
Order No	206.72.	019	020	024	025	030	032	038	040	048	050	063
d_2	33,2	34,2	39,1	40,5	49	51,4	59,1	60,8	70,2	72,6	87	

FIBRO

2081.81.

**Headed Guide Bushes
to ISO 9448, Steel,
with bronze coated internal bore**

2081.81.

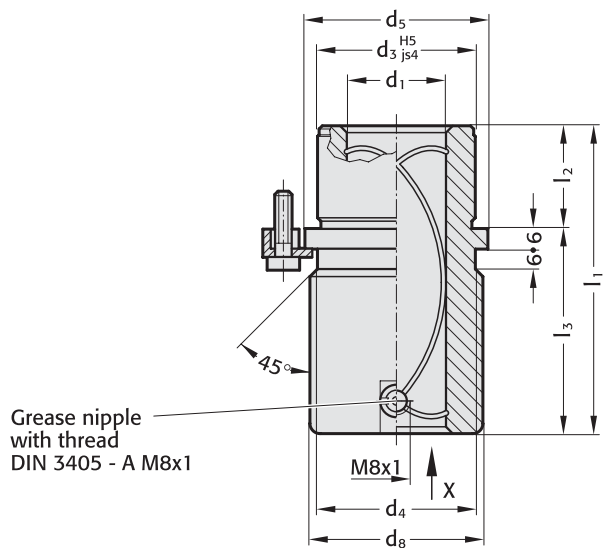

Grease nipple with thread
DIN 3405 - A M8x1

207.45

Order No. for replacement parts
Screw clamp with cap screws
M6 x 20 similar
DIN 6912, head ø13,
(four clamps for size
ød₁ = 38 mm and over)

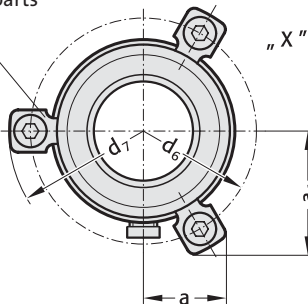

Mounting Examples

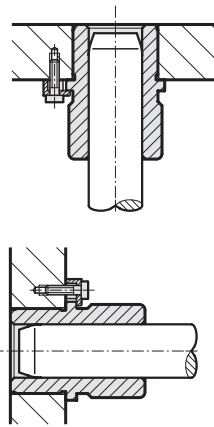

Note:

Headed Guide Bushes are to be held in H5-retainer bores. Three screw clamps are provided for fixing; sizes d₁ = 38 mm and over have four.

Guide pairing:

We recommend the use of guide pillars from pairing class .20/.30

These guide bushes are supplied complete with clamps and low-head socket cap screws similar DIN 6912, head Ø 13.

Material:

Ø d₃ and d₈ 1.0503
induction hardened to 500+100 HV 10.

Execution:

Bronze coated internal bore.
Diameter d₃ and collar face precision ground.

2081.81.

d ₁	19 20	24 25	30 32	38 40	48 50	60 63	80
tol.	+0,012	+0,012	+0,015	+0,015	+0,015	+0,018	+0,018
	+0,003	+0,003	+0,004	+0,004	+0,004	+0,005	+0,005
d ₃	32	40	48	58	70	85	105
d ₄	32	40	48	58	70	85	105
d ₅	40	48	56	66	80	95	118
d ₆	52	60	67	77	91	106	129
d ₇	64,7	72,7	79,7	89,7	103,7	118,7	141,7
d ₈	39	46	53	63	77	92	115
a	20,7	22,65	24,4	35,3	40,2	45,5	54,5
a ₁	30	33,4	36,4	35,3	40,2	45,5	54,5
l ₁	59	79	93	108	127	150	150
l ₂	23	23	30	37	47	60	60
l ₃	36	56	63	71	80	90	90

Ordering code (example):

Headed guide bush = 2081.81.
d₁ = 40 mm = 040
Order No = 2081.81.040

Headed Guide Bushes to ISO 9448, Steel, with bronze coated internal bore

FIBRO

2081.84.

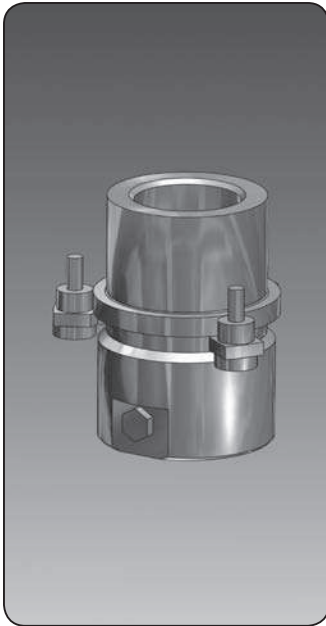

Mounting Examples

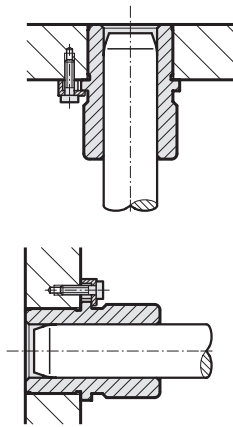

2081.84.

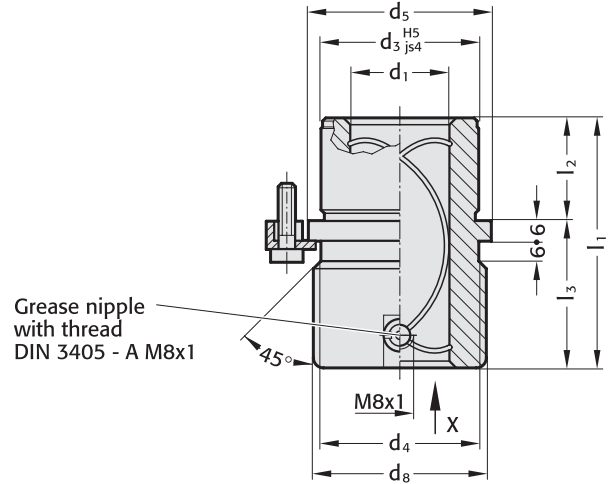

Note:

Headed Guide Bushes are to be held in H5-retainer bores. Three screw clamps are provided for fixing; sizes $d_1 = 38$ mm and over have four.

Guide pairing:

We recommend the use of guide pillars from pairing class .20/.30

These guide bushes are supplied complete with clamps and low-head socket cap screws similar DIN 6912, head $\varnothing 13$.

Material: 1.0503
 $\varnothing d_3$ and d_8 induction hardened to 500+100 HV 10.

Execution: Bronze coated internal bore.
Diameter d_3 and collar face precision ground.

207.45

Order No. for replacement parts

Screw clamp with cap screws M6 x 20 similar DIN 6912, head $\varnothing 13$, (four clamps for size $\varnothing d_1 = 38$ mm and over)

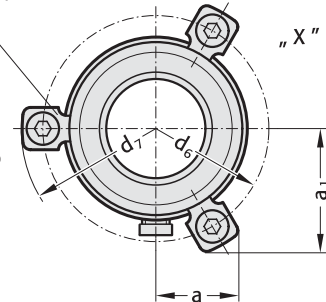

2081.84.

d_1	19 20	24 25	30 32	38 40	48 50	60 63	80
tol.	+0,012 +0,003	+0,012 +0,003	+0,015 +0,004	+0,015 +0,004	+0,015 +0,004	+0,018 +0,005	+0,018 +0,005
d_3	32	40	48	58	70	85	105
d_4	32	40	48	58	70	85	105
d_5	40	48	56	66	80	95	118
d_6	52	60	67	77	91	106	129
d_7	64,7	72,7	79,7	89,7	103,7	118,7	141,7
d_8	39	46	53	63	77	92	115
a	20,7	22,65	24,4	35,3	40,2	45,5	54,5
a_1	30	33,4	36,4	35,3	40,2	45,5	54,5
l_1	43	59	75	82	97	116	120
l_2	23	23	30	37	47	60	60
l_3	20	36	45	45	50	56	60

Ordering code (example):

Headed guide bush = 2081.84.

$d_1 = 40$ mm = 040

Order No = 2081.84.040

FIBRO

**Headed Guide Bushes
to ISO 9448,
Steel, with bronze coated internal bore**

2081.85.

2081.85.

Grease nipple
with thread
DIN 3405 - A M8x1

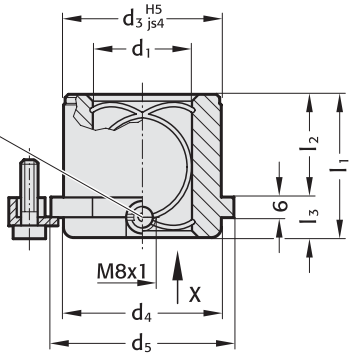

207.45

Order No. for replacement parts

Screw clamp
with cap screws
M6 x 20 similar
DIN 6912,
head Ø13,
(four clamps for size
Ød₁ = 38 mm and over)

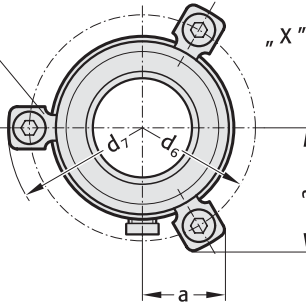

Mounting Examples

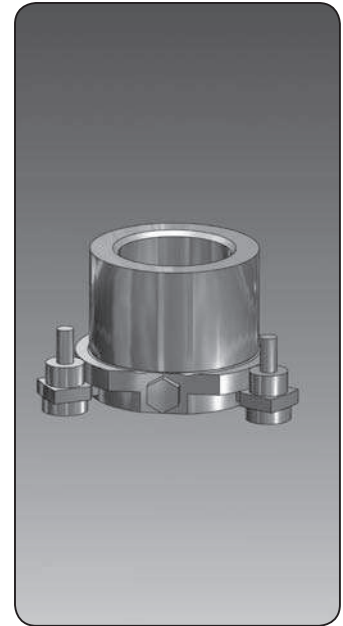
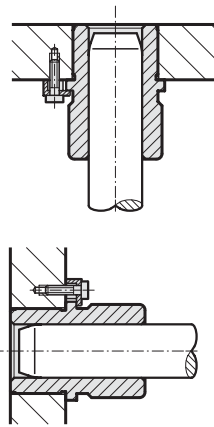

Note:

Headed Guide Bushes are to be held in H5-retainer bores. Three screw clamps are provided for fixing; sizes d₁ = 38 mm and over have four.

Guide pairing:

We recommend the use of guide pillars from pairing class .20/.30

These guide bushes are supplied complete with clamps and low-head socket cap screws similar DIN 6912, head Ø 13.

Material: 1.0503
Ø d₃ and d₈ induction hardened to 500+100 HV 10.

Execution: Bronze coated internal bore.
Diameter d₃ and collar face precision ground.

2081.85.

d ₁	19 20	24 25	30 32	38 40	48 50	60 63	80
tol.	+0,012	+0,012	+0,015	+0,015	+0,015	+0,018	+0,018
	+0,003	+0,003	+0,004	+0,004	+0,004	+0,005	+0,005
d ₃	32	40	48	58	70	85	105
d ₄	32	40	48	58	70	85	105
d ₅	40	48	56	66	80	95	118
d ₆	52	60	67	77	91	106	129
d ₇	64,7	72,7	79,7	89,7	103,7	118,7	141,7
d ₈	39	46	53	63	77	92	115
a	20,7	22,65	24,4	35,3	40,2	45,5	54,5
a ₁	30	33,4	36,4	35,3	40,2	45,5	54,5
l ₁	35	35	42	52	65	80	80
l ₂	23	23	30	37	47	60	60
l ₃	12	12	12	15	18	20	20

Ordering code (example):

Headed guide bush = 2081.85.
d₁ = 40 mm = 040
Order No = 2081.85.040

Headed Guide Bushes to DIN 9831/ISO 9448-6, sintered ferrite, carbonitrided, long-term lubrication

FIBRO

2081.31.



Mounting examples

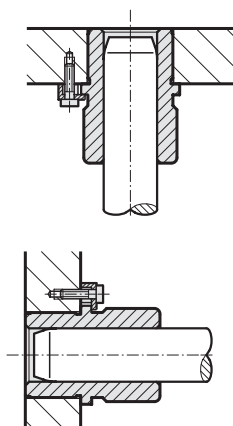

2081.31.

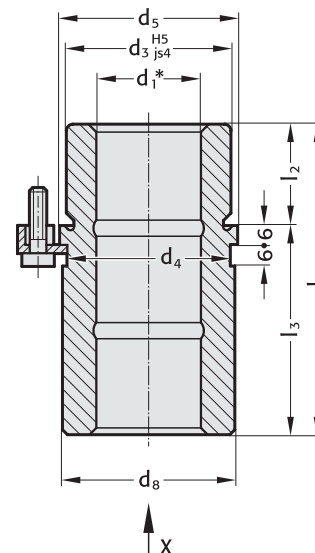

Note:

Headed Guide Bushes are to be held in H5-retainer bores. Three screw clamps are provided for fixing; sizes $d_1 = 38$ mm and over have four.

FIBRO headed guide bushes of sintered ferrite carbonitrided are fully interchangeable with the corresponding sizes of the FIBRO headed ball bearing guide bushes.

Notes on Sliding- and Ball Bearing Guides: page D9.

Guide Pillars: see pages D16, D17, D18, D22 and D35.

These guide bushes are supplied complete with clamps and low-head socket cap screws similar DIN 6912, head $\varnothing 13$.

Material:

Sintered ferrite of high purity, carbonitrided

Execution:

Bore, diameter d_3 and collar face precision ground.

207.45

Order No for replacement parts

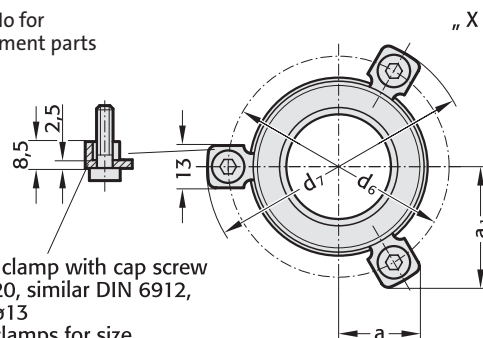

Screw clamp with cap screw
M6 x 20, similar DIN 6912,
head $\varnothing 13$
(four clamps for size
 $d_1 = 38$ mm and over)

* Colour Code Combinations/Clearances – see pages D10 and D11.

2081.31.

d_1	19 20	24 25	30 32	38 40	48 50	60 63
d_3	32	40	48	58	70	85
d_4	32	40	48	58	70	85
d_5	40	48	56	66	80	95
d_6	52	60	67	77	91	106
d_7	64,7	72,7	79,7	89,7	103,7	118,7
d_8	39	46	53	63	77	92
a	20,7	22,65	24,4	35,3	40,2	45,5
a_1	30	33,4	36,4	35,3	40,2	45,5
l_1	59	79	93	108	127	150
l_2	23	23	30	37	47	60
l_3	36	56	63	71	80	90

Ordering Code (example):

Headed Guide Bush = 2081.31. Tolerance range – yellow = .10
 $d_1 = 40$ mm = 040. green = .20
 Tolerance range – yellow = 10 red = .30
 Order No = 2081.31.040.10

FIBRO

2081.32.

Headed Guide Bushes
to DIN 9831/ISO 9448-6, sintered ferrite,
carbonitrided, long-term lubrication

2081.32.

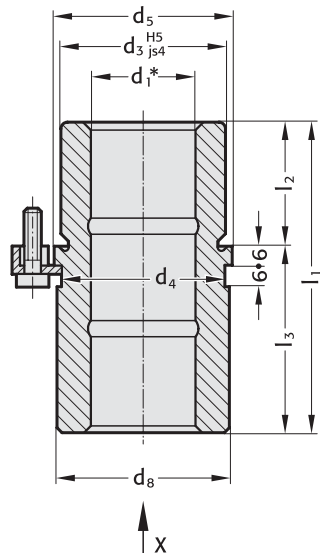

207.45

Order No for replacement parts

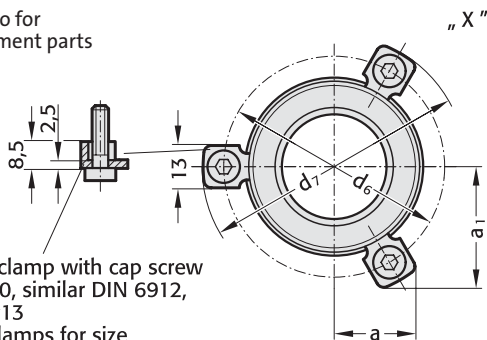

Screw clamp with cap screw
M6 x 20, similar DIN 6912,
head Ø13
(four clamps for size
d₁ = 38mm and over)

* Colour Code Combinations/Clearances – see pages D 10 and D 11.

Mounting examples

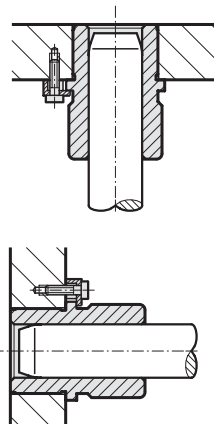

Note:

Headed Guide Bushes are to be held in H5-retainer bores. Three screw clamps are provided for fixing; sizes d₁ = 38 mm and over have four.

FIBRO headed guide bushes of sintered ferrite carbonitrided are fully interchangeable with the corresponding sizes of the FIBRO headed ball bearing guide bushes.

Notes on Sliding- and Ball Bearing Guides: page D9.

Guide Pillars: see pages D16, D17, D18, D22 and D35.

These guide bushes are supplied complete with clamps and low-head socket cap screws similar DIN 6912, head Ø 13.

Material:

Sintered ferrite of high purity, carbonitrided

Execution:

Bore, diameter d₃ and collar face precision ground.

2081.32.

d ₁	24 25	30 32	38 40	48 50
d ₃	40	48	58	70
d ₄	40	48	58	70
d ₅	48	56	66	80
d ₆	60	67	77	91
d ₇	72,7	79,7	89,7	103,7
d ₈	46	53	63	77
a	22,65	24,4	35,3	40,2
a ₁	33,4	36,4	35,3	40,2
l ₁	80	93	110	131
l ₂	30	37	47	60
l ₃	50	56	63	71

Ordering Code (example):

Headed Guide Bush	= 2081.32.	Tolerance range – yellow	= .10
d ₁ = 30 mm	= 030.	green	= .20
Tolerance range – green	= 20	red	= .30
Order No	= 2081.32.030.20		

Headed Guide Bushes
to DIN 9831/ISO 9448-6, sintered ferrite,
carbonitrided, long-term lubrication

FIBRO

2081.33.



Mounting examples

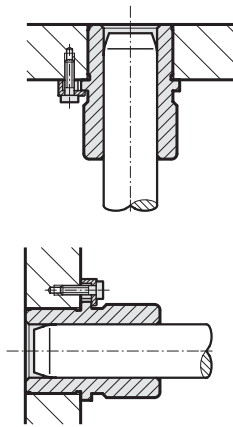

2081.33.

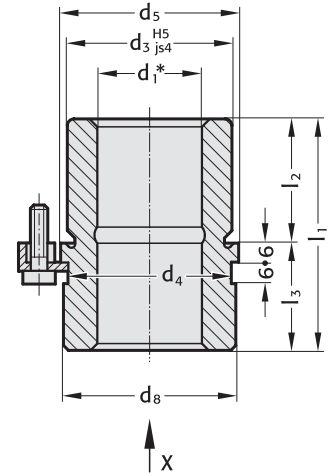

Note:

Headed Guide Bushes are to be held in H5-retainer bores. Three screw clamps are provided for fixing; sizes $d_1 = 38$ mm and over have four.

FIBRO headed guide bushes of sintered ferrite carbonitrided are fully interchangeable with the corresponding sizes of the FIBRO headed ball bearing guide bushes.

Notes on Sliding- and Ball Bearing Guides: page D 9.

Guide Pillars: see pages D16, D17, D18, D22 and D35.

These guide bushes are supplied complete with clamps and low-head socket cap screws similar DIN 6912, head $\varnothing 13$.

Material:

Sintered ferrite of high purity, carbonitrided

Execution:

Bore, diameter d_3 and collar face precision ground.

207.45

Order No for replacement parts

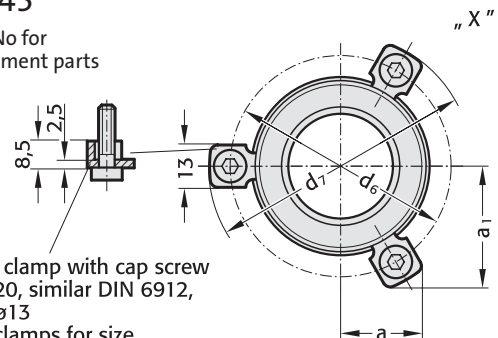

Screw clamp with cap screw
M6 x 20, similar DIN 6912,
head $\varnothing 13$
(four clamps for size
 $d_1 = 38$ mm and over)

* Colour Code Combinations/Clearances – see pages D10 and D 11.

2081.33.

d_1	24 25	30 32	38 40	48 50
d_3	40	48	58	70
d_4	40	48	58	70
d_5	48	56	66	80
d_6	60	67	77	91
d_7	72,7	79,7	89,7	103,7
d_8	46	53	63	77
a	22,65	24,4	35,3	40,2
a_1	33,4	36,4	35,3	40,2
l_1	55	69	79	96
l_2	30	37	47	60
l_3	25	32	32	36

Ordering Code (example):

Headed Guide Bush	= 2081.33.	Tolerance range – yellow	= .10
$d_1 = 40$ mm	= 040.	green	= .20
Tolerance range – yellow	= 10	red	= .30
Order No	= 2081.33.040.10		

FIBRO

**Headed Guide Bushes
to DIN 9831/ISO 9448-6, sintered ferrite
carbonitrided, long-term lubrication**

2081.34.

2081.34.

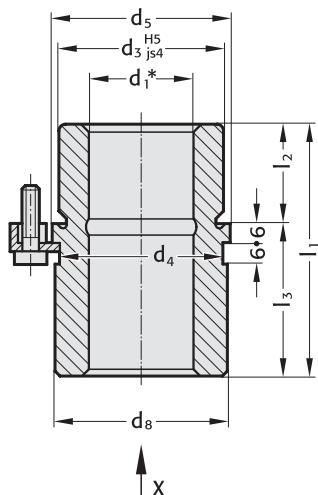

207.45

Order No for replacement parts

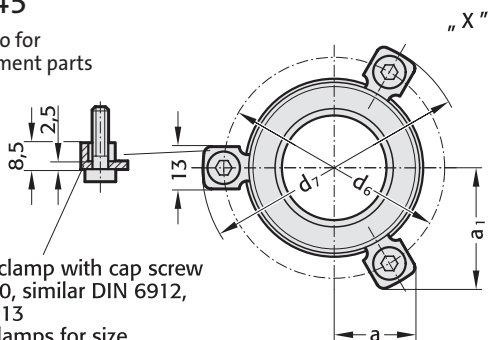

Screw clamp with cap screw
M6 x 20, similar DIN 6912,
head Ø13
(four clamps for size
d₁ = 38mm and over)

* Colour Code Combinations/Clearances – see pages D10 and D 11.

Mounting examples

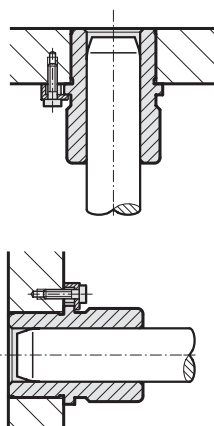

Note:

Headed Guide Bushes are to be held in H5-retainer bores. Three screw clamps are provided for fixing; sizes d₁ = 38 mm and over have four.

FIBRO headed guide bushes of sintered ferrite carbonitrided are fully interchangeable with the corresponding sizes of the FIBRO headed ball bearing guide bushes.

Notes on Sliding- and Ball Bearing Guides: page D9.

Guide Pillars: see pages D16, D17, D18, D22 and D35.

These guide bushes are supplied complete with clamps and low-head socket cap screws similar DIN 6912, head Ø 13.

Material:

Sintered ferrite of high purity, carbonitrided

Execution:

Bore, diameter d₃ and collar face precision ground.

2081.34.

d ₁	19 20	24 25	30 32	38 40	48 50	60 63
d ₃	32	40	48	58	70	85
d ₄	32	40	48	58	70	85
d ₅	40	48	56	66	80	95
d ₆	52	60	67	77	91	106
d ₇	64,7	72,7	79,7	89,7	103,7	118,7
d ₈	39	46	53	63	77	92
a	20,7	22,65	24,4	35,3	40,2	45,5
a ₁	30	33,4	36,4	35,3	40,2	45,5
l ₁	43	59	75	82	97	116
l ₂	23	23	30	37	47	60
l ₃	20	36	45	45	50	56

Ordering Code (example):

Headed Guide Bush	= 2081.34.	Tolerance range – yellow	= .10
d ₁ = 30 mm	= 030.	green	= .20
Tolerance range –green	= 20	red	= .30
Order No	= 2081.34.030.20		

Headed Guide Bushes to DIN 9831/ISO 9448-6, sintered ferrite, carbonitrided, long-term lubrication

FIBRO

2081.35.

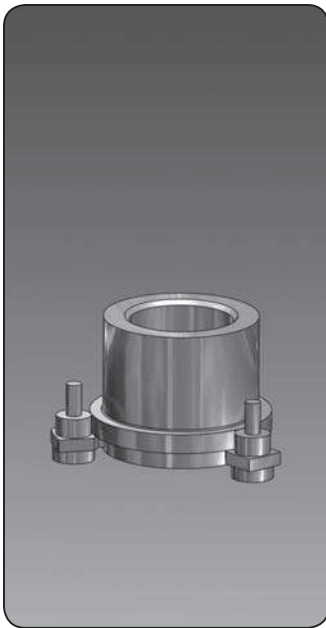

Mounting examples

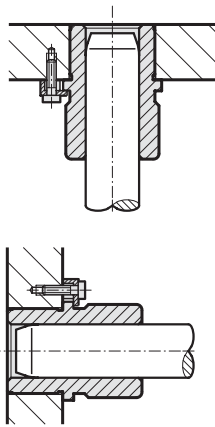

2081.35.

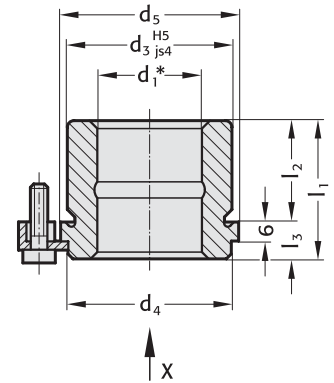

Note:

Headed Guide Bushes are to be held in H5-retainer bores. Three screw clamps are provided for fixing; sizes $d_1 = 38$ mm and over have four.

FIBRO headed guide bushes of sintered ferrite carbonitrided are fully interchangeable with the corresponding sizes of the FIBRO headed ball bearing guide bushes.

Notes on Sliding- and Ball Bearing Guides: page D9.

Guide Pillars: see pages D16, D17, D18, D22 and D35.

These guide bushes are supplied complete with clamps and low-head socket cap screws similar DIN 6912, head $\varnothing 13$.

Material:

Sintered ferrite of high purity, carbonitrided

Execution:

Bore, diameter d_3 and collar face precision ground.

207.45

Order No for replacement parts

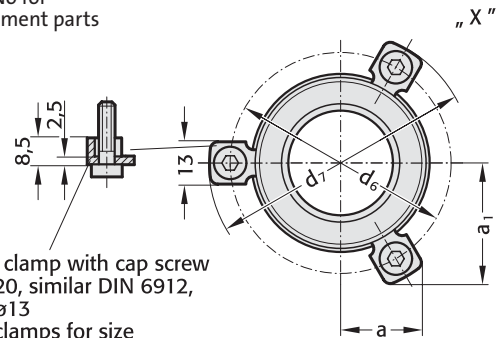

Screw clamp with cap screw
M6 x 20, similar DIN 6912,
head $\varnothing 13$
(four clamps for size
 $d_1 = 38$ mm and over)

* Colour Code Combinations/Clearances – see pages D10 and D 11.

2081.35.

d_1	19 20	24 25	30 32	38 40	48 50	60 63
d_3	32	40	48	58	70	85
d_4	32	40	48	58	70	85
d_5	40	48	56	66	80	95
d_6	52	60	67	77	91	106
d_7	64,7	72,7	79,7	89,7	103,7	118,7
a	20,7	22,65	24,4	35,3	40,2	45,5
a_1	30	33,4	36,4	35,3	40,2	45,5
l_1	35	35	42	52	65	80
l_2	23	23	30	37	47	60
l_3	12	12	12	15	18	20

Ordering Code (example):

Headed Guide Bush	= 2081.33.	Tolerance range – yellow	= .10
$d_1 = 40$ mm	= 040.	green	= .20
Tolerance range – yellow	= 10	red	= .30
Order No	= 2081.33.040.10		

FIBRO

2081.91.

ECO-LINE
**Headed Guide Bushes,
 bronzeplated**

2081.91.

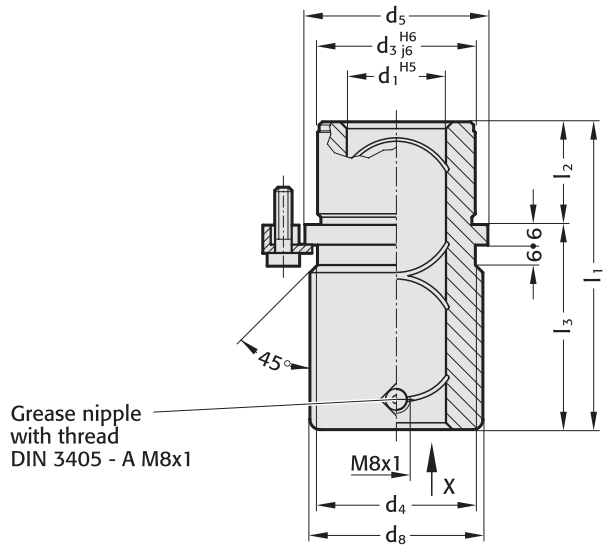

Grease nipple with thread
 DIN 3405 - A M8x1

207.45

Order No for replacement parts

Screw clamp with cap screws
 M6 x 20, similar
 DIN 6912,
 head $\varnothing 13$,
 (four clamps for size
 $\varnothing d_1 = 38$ and over)

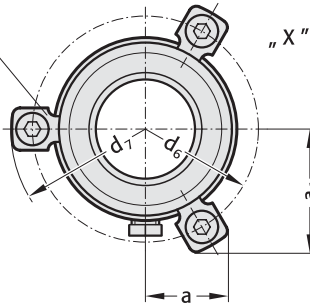

Mounting examples

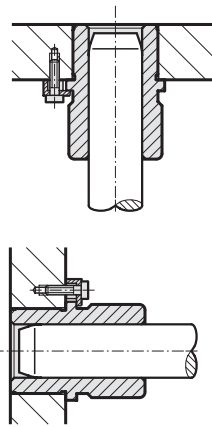

Note:

Headed Guide Bushes are to be held in H6-retainer bores. Three screw clamps are provided for fixing; sizes $d_1 = 38$ mm and over have four. These guide bushes are supplied complete with clamps and low-head socket cap screws similar DIN 6912, head $\varnothing 13$.

Material: Steel
 $\varnothing d_3$ induction hardened

Execution: Bronze plated internal bore.
 Diameter d_3 and collar face precision ground.

2081.91.

d_1	19 20	24 25	30 32	38 40	48 50	60 63	80
d_3	32	40	48	58	70	85	105
d_4	32	40	48	58	70	85	105
d_5	40	48	56	66	80	95	118
d_6	52	60	67	77	91	106	129
d_7	64,7	72,7	79,7	89,7	103,7	118,7	141,7
d_8	39	46	53	63	77	92	115
a	20,7	22,65	24,4	35,3	40,2	45,5	54,5
a_1	30	33,4	36,4	35,3	40,2	45,5	54,5
l_1	59	79	93	108	127	150	150
l_2	23	23	30	37	47	60	60
l_3	36	56	63	71	80	90	90

Ordering code (example):

Headed Guide Bushes, bronzeplated = 2081.91.
 $d_1 = 40$ mm = 040
 Order No = 2081.91.040

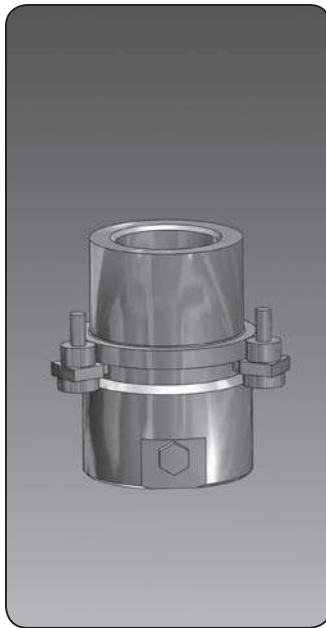

Mounting example

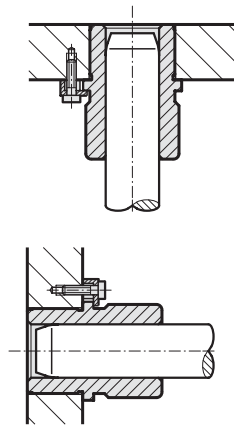

2081.94.

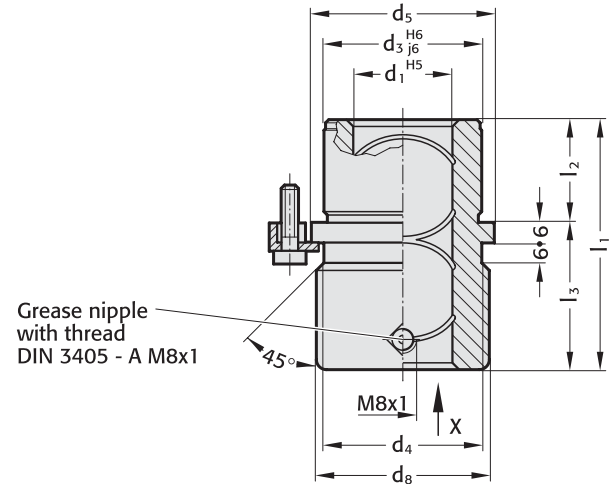

Note:

Headed Guide Bushes are to be held in H6-retainer bores. Three screw clamps are provided for fixing; sizes $d_1 = 38$ mm and over have four.
These guide bushes are supplied complete with clamps and low-head socket cap screws similar DIN 6912, head $\varnothing 13$.

Material: Steel
 $\varnothing d_3$ induction hardened

Execution: Bronze plated internal bore.
Diameter d_3 and collar face precision ground.

207.45

Order No for replacement parts

Screw clamp with cap screws M6 x 20, similar DIN 6912, head $\varnothing 13$, (four clamps for size $\varnothing d_1 = 38$ and over)

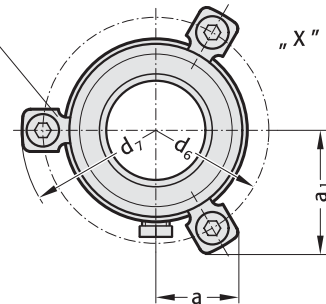

2081.94.

d_1	19 20	24 25	30 32	38 40	48 50	60 63	80
d_3	32	40	48	58	70	85	105
d_4	32	40	48	58	70	85	105
d_5	40	48	56	66	80	95	118
d_6	52	60	67	77	91	106	129
d_7	64,7	72,7	79,7	89,7	103,7	118,7	141,7
d_8	39	46	53	63	77	92	115
a	20,7	22,65	24,4	35,3	40,2	45,5	54,5
a_1	30	33,4	36,4	35,3	40,2	45,5	54,5
l_1	43	59	75	82	97	116	120
l_2	23	23	30	37	47	60	60
l_3	20	36	45	45	50	56	60

Ordering Code (example):

Headed Guide Bushes, bronzeplated = 2081.94.
 $d_1 = 63$ mm = 063
 Order No = 2081.94.063

FIBRO

2081.95.

ECO-LINE
**Headed Guide Bushes,
 bronzeplated**

2081.95.

Grease nipple
 with thread
 DIN 3405 - A M8x1

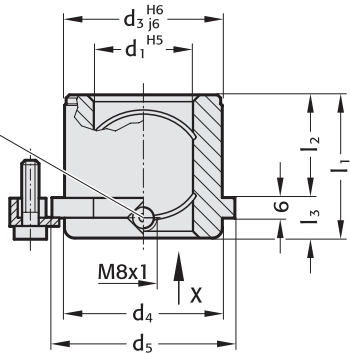

207.45

Order No for
 replacement parts

Screw clamp
 with cap screws
 M6 x 20, similar
 DIN 6912,
 head ø13,
 (four clamps for size
 ød1 = 38 and over)

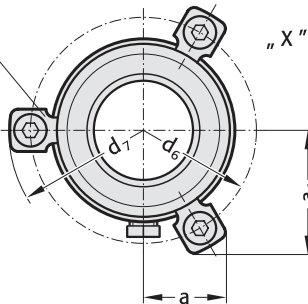

Mounting example

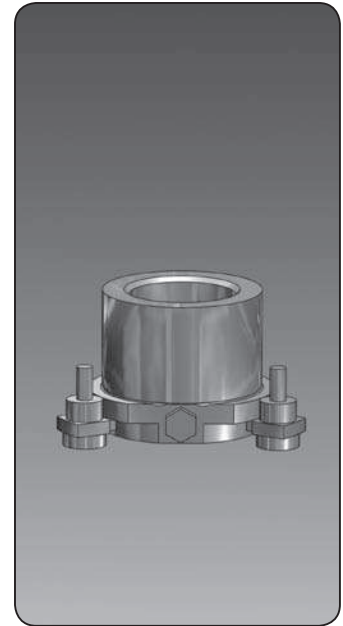
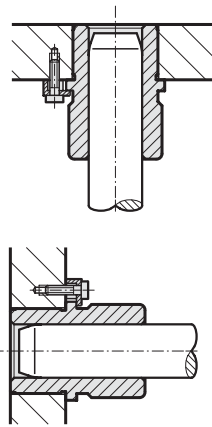

Note:

Headed Guide Bushes are to be held in H6-retainer bores. Three screw clamps are provided for fixing; sizes $d_1 = 38$ mm and over have four. These guide bushes are supplied complete with clamps and low-head socket cap screws similar DIN 6912, head $\varnothing 13$.

Material: Steel
 $\varnothing d_3$ induction hardened

Execution: Bronze plated internal bore.
 Diameter d_3 and collar face precision ground.

2081.95.

d_1	19 20	24 25	30 32	38 40	48 50	60 63	80
d_3	32	40	48	58	70	85	105
d_4	32	40	48	58	70	85	105
d_5	40	48	56	66	80	95	118
d_6	52	60	67	77	91	106	129
d_7	64,7	72,7	79,7	89,7	103,7	118,7	141,7
d_8	39	46	53	63	77	92	115
a	20,7	22,65	24,4	35,3	40,2	45,5	54,5
a_1	30	33,4	36,4	35,3	40,2	45,5	54,5
l_1	35	35	42	52	65	80	80
l_2	23	23	30	37	47	60	60
l_3	12	12	12	15	18	20	20

Ordering Code (example):

Headed Guide Bushes, bronzeplated = 2081.95.
 $d_1 = 63$ mm = 063
 Order No = 2081.95.063

Headed Guide Bushes,
Bronze with solid lubrication rings

2081.71.



Mounting Example

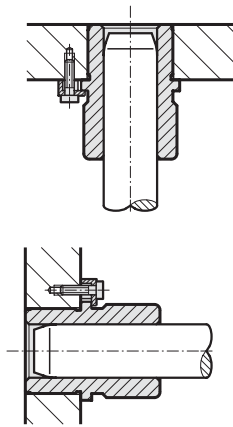

2081.71.

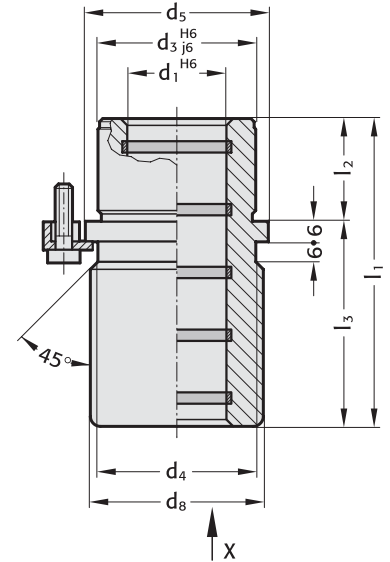

Note:

Headed Guide Bushes are to be held in H6-retainer bores. Three screw clamps are provided for fixing; sizes $d_1 = 38$ mm and over have four.
These guide bushes are supplied complete with clamps and low-head socket cap screws similar DIN 6912, head $\varnothing 13$.

Material: Bronze

Execution: Contact surfaces with solid lubricant rings.
Diameter d_3 and collar face precision ground.

207.45

Order No for replacement parts

Screw clamp with cap screws M6 x 20, similar DIN 6912, head $\varnothing 13$, (four clamps for size $\varnothing d_1 = 38$ and over)

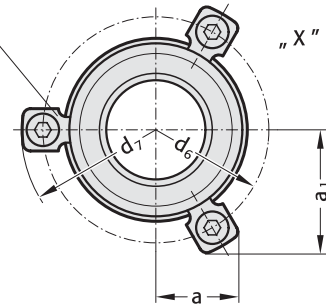

2081.71.

d_1	19 20	24 25	30 32	38 40	48 50	60 63	80
d_3	32	40	48	58	70	85	105
d_4	32	40	48	58	70	85	105
d_5	40	48	56	66	80	95	118
d_6	52	60	67	77	91	106	129
d_7	64,7	72,7	79,7	89,7	103,7	118,7	141,7
d_8	39	46	53	63	77	92	115
a	20,7	22,65	24,4	35,3	40,2	45,5	54,5
a_1	30	33,4	36,4	35,3	40,2	45,5	54,5
l_1	59	79	93	108	127	150	150
l_2	23	23	30	37	47	60	60
l_3	36	56	63	71	80	90	90

Ordering Code (example):

Headed Guide Bushes, Bronze = 2081.71.

$d_1 = 40$ mm = 040

Order No = 2081.71.040

FIBRO

2081.74.

ECO-LINE

Headed Guide Bushes,
Bronze with solid lubrication rings

2081.74.

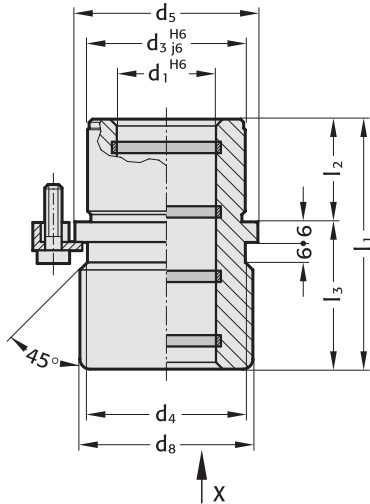

207.45

Order No for replacement parts

Screw clamp with cap screws M6 x 20, similar DIN 6912, head ø13, (four clamps for size ød₁ = 38 and over)

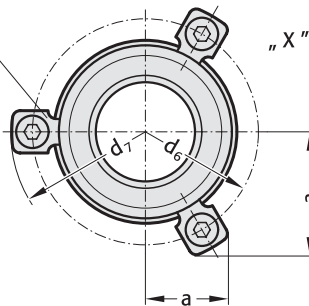

Mounting Example

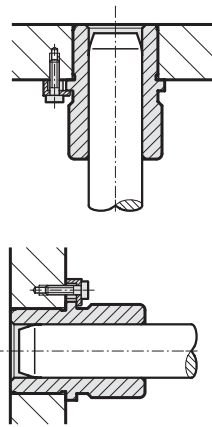

Note:

Headed Guide Bushes are to be held in H6-retainer bores. Three screw clamps are provided for fixing; sizes d₁ = 38 mm and over have four. These guide bushes are supplied complete with clamps and low-head socket cap screws similar DIN 6912, head ø 13.

Material: Bronze

Execution: Contact surfaces with solid lubricant rings. Diameter d₃ and collar face precision ground.

2081.74.

d ₁	19 20	24 25	30 32	38 40	48 50	60 63	80
d ₃	32	40	48	58	70	85	105
d ₄	32	40	48	58	70	85	105
d ₅	40	48	56	66	80	95	118
d ₆	52	60	67	77	91	106	129
d ₇	64,7	72,7	79,7	89,7	103,7	118,7	141,7
d ₈	39	46	53	63	77	92	115
a	20,7	22,65	24,4	35,3	40,2	45,5	54,5
a ₁	30	33,4	36,4	35,3	40,2	45,5	54,5
l ₁	43	59	75	82	97	116	120
l ₂	23	23	30	37	47	60	60
l ₃	20	36	45	45	50	56	60

Ordering Code (example):

Headed Guide Bushes, Bronze = 2081.74.

d₁ = 25 mm = 025

Order No = 2081.74.025

ECO-LINE
**Headed Guide Bushes,
 Bronze with solid lubrication rings**

FIBRO

2081.75.

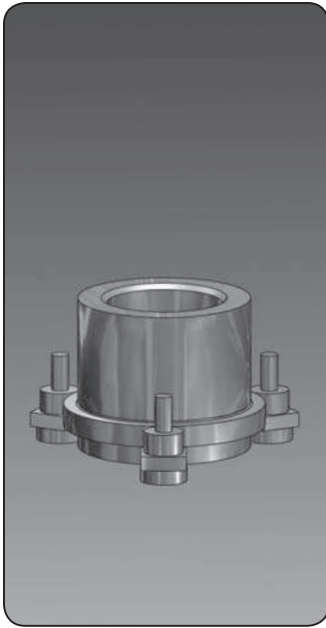

Mounting Example

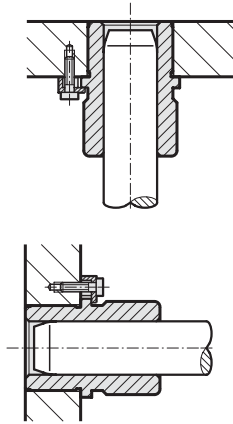

2081.75.

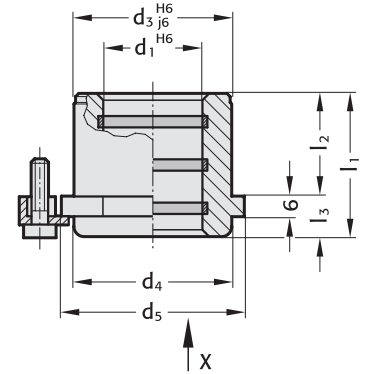

Note:

Headed Guide Bushes are to be held in H6-retainer bores. Three screw clamps are provided for fixing; sizes $d_1 = 38$ mm and over have four.
 These guide bushes are supplied complete with clamps and low-head socket cap screws similar DIN 6912, head $\varnothing 13$.

Material: Bronze

Execution: Contact surfaces with solid lubricant rings.
 Diameter d_3 and collar face precision ground.

207.45

Order No for replacement parts

Screw clamp with cap screws M6 x 20, similar DIN 6912, head $\varnothing 13$, (four clamps for size $\varnothing d_1 = 38$ and over)

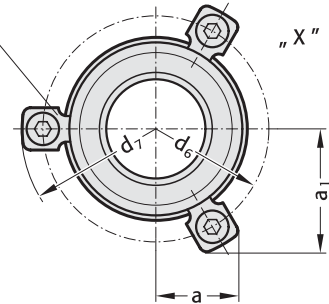

2081.75.

d_1	19 20	24 25	30 32	38 40	48 50	60 63	80
d_3	32	40	48	58	70	85	105
d_4	32	40	48	58	70	85	105
d_5	40	48	56	66	80	95	118
d_6	52	60	67	77	91	106	129
d_7	64,7	72,7	79,7	89,7	103,7	118,7	141,7
d_8	39	46	53	63	77	92	115
a	20,7	22,65	24,4	35,3	40,2	45,5	54,5
a_1	30	33,4	36,4	35,3	40,2	45,5	54,5
l_1	35	35	42	52	65	80	80
l_2	23	23	30	37	47	60	60
l_3	12	12	12	15	18	20	20

Ordering Code (example):

Headed Guide Bushes, Bronze = 2081.75.

$d_1 = 63$ mm = 063

Order No = 2081.75.063

FIBRO

2081.44.
206.71.

Headed Guide Bushes for Ball Bearings DIN 9831/ISO 9448-7 Ball Cages

2081.44.

to order separate:
Ball Cage
206.71.

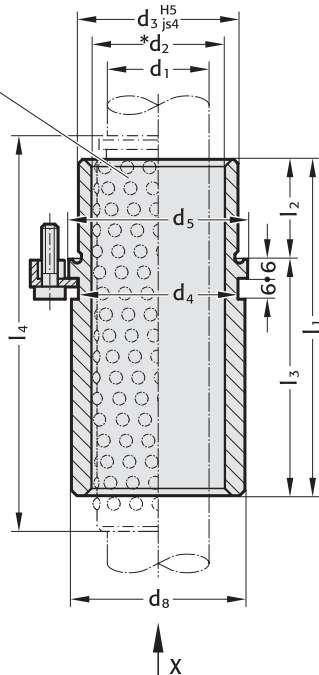

207.45

Order No for replacement parts

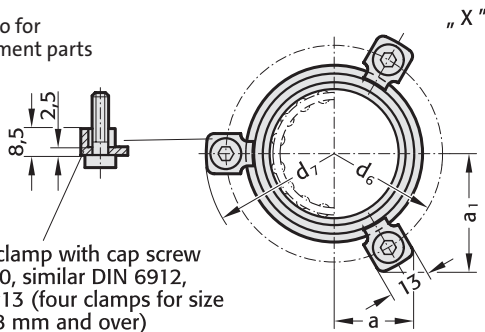

* Preloading see Colour Code Combinations – pages D10 and D11.

Execution:

Bearing surfaces honed.
Outside diameter fine-ground.

Note:

Headed Guide Bushes are to be held in H5-retainer bores.

Three screw clamps are provided for fixing; sizes $\varnothing d_1 = 38$ mm and over have four.

FIBRO headed guide bushes for ball bearings are fully interchangeable with the corresponding sizes of the FIBRO headed guide bushes of sintered ferrite.

Notes on Sliding and Ball Bearing Guides see page D9.

Guide Pillars see pages D16, D17, D18, D22 and D35.

Ball guide capacity calculations see pages D56 and D57.

Material:

Bush: tool steel, Hardness: 62 ± 2 HRC

Ball Cage: brass

Balls: hardened steel DIN 5401



2081.44.

d_1	19 20	24 25	30 32	38 40	48 50	60 63	80
d_2	25 26	30 31	38 40	46 48	56 58	68 71	92
d_3	32	40	48	58	70	85	105
d_4	32	40	48	58	70	85	105
d_5	40	48	56	66	80	95	118
d_6	52	60	67	77	91	106	129
d_7	64,7	72,7	79,7	89,7	103,7	118,7	141,7
d_8	39	46	53	63	77	92	115
a	20,7	22,65	24,4	35,3	40,2	45,5	54,5
a_1	30	33,4	36,4	35,3	40,2	45,5	54,5
l_1	59	79	93	108	127	150	150
l_2	23	23	30	37	47	60	60
l_3	36	56	63	71	80	90	90

206.71. (preferred length)

d_1	19 20	24 25	30 32	38 40	48 50	60 63	80	
l	71	95	120	120	140	160	160	l = Nominal ordering length
l_4	72	96	120	120	140	160	161	l_4 = Manufacturing length

Ordering Code (example):

Headed Guide Bush	= 2081.44.	Ball Cages	= 206.71.	Tolerance range – yellow	= .10
$d_1 = 40$ mm	= 040.	$d_1 = 40$ mm	= 040.	green	= .20
Tolerance range – red	= 30	l = 120 mm	= 120	red	= .30
Order No	= 2081.44.040.30	Order No	= 206.71.040.120		

Headed Guide Bushes for Ball Bearings DIN 9831/ISO 9448-7 Ball Cages

FIBRO
2081.45.
206.71.

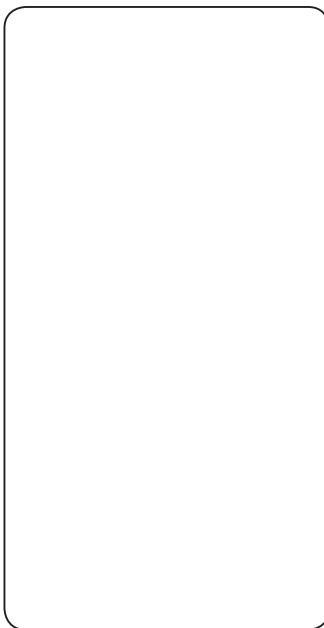

2081.45.

to order
separate:
Ball Cage
206.71.

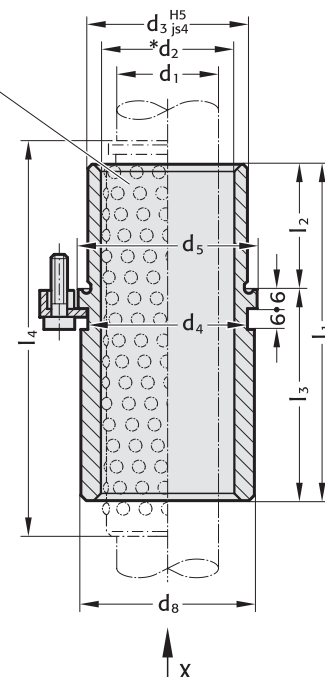

Execution:

Bearing surfaces honed.
Outside diameter fine-ground.

Note:

Headed Guide Bushes are to be held in H5-retainer bores.

Three screw clamps are provided for fixing; sizes $\varnothing d_1 = 38$ mm and over have four.

FIBRO headed guide bushes for ball bearings are fully interchangeable with the corresponding sizes of the FIBRO headed guide bushes of sintered ferrite.

Notes on Sliding and Ball Bearing Guides see page D9.

Guide Pillars see pages D16, D17, D18, D22 and D35.

Ball guide capacity calculations see pages D56 and D57.

Material:

Bush: tool steel, Hardness: 62 ± 2 HRC
Ball Cage: brass
Balls: hardened steel DIN 5401

207.45

Order No for
replacement parts

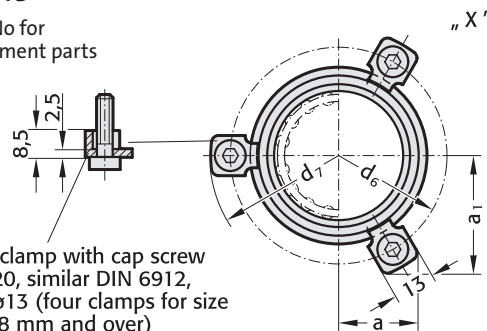

screw clamp with cap screw
M6 x 20, similar DIN 6912,
head $\varnothing 13$ (four clamps for size
 $d_1 = 38$ mm and over)

* Preloading see Colour Code Combinations – pages D10 and D11.

2081.45.

d_1	24 25	30 32	38 40	48 50
d_2	30 31	38 40	46 48	56 58
d_3	40	48	58	70
d_4	40	48	58	70
d_5	48	56	66	80
d_6	60	67	77	91
d_7	72,7	79,7	89,7	103,7
d_8	46	53	63	77
a	22,65	24,4	35,3	40,2
a_1	33,4	36,4	35,3	40,2
l_1	80	93	110	131
l_2	30	37	47	60
l_3	50	56	63	71

206.71. (preferred length)

d_1	24 25	30 32	38 40	48 50	
l	95	120	140	160	l = Nominal ordering length
l_4	96	120	140	160	l_4 = Manufacturing length

Ordering Code (example):

Headed Guide Bush = 2081.45.	Ball Cages = 206.71.	Tolerance yellow = .10
$d_1 = 40$ mm = 040.	$d_1 = 40$ mm = 040.	range – green = .20
Tolerance range- red = 30	l = 120 mm = 120	red = .30
Order No = 2081.45.040.30	Order No = 206.71.040.120	

FIBRO

2081.46.
206.71.

Headed Guide Bushes for Ball Bearings DIN 9831/ISO 9448-7 Ball Cages

2081.46.

to order
separate:
Ball Cage
206.71.

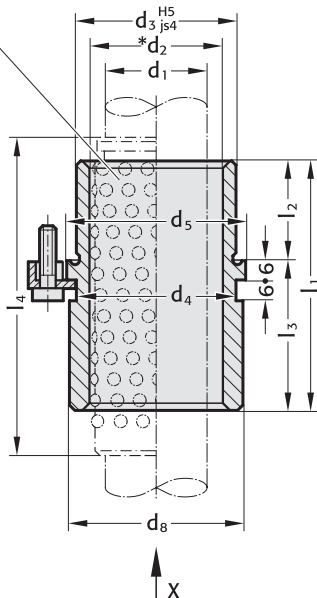

207.45

Order No for
replacement parts

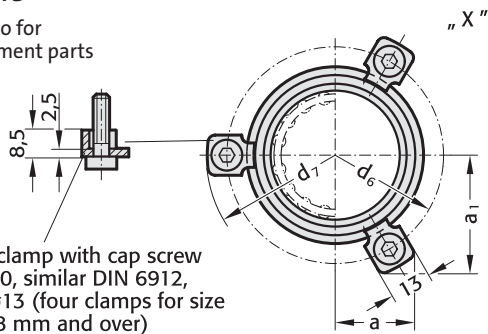

screw clamp with cap screw
M6 x 20, similar DIN 6912,
head ø13 (four clamps for size
d1 = 38 mm and over)

* Preloading see Colour Code Combinations – pages D10 and D11.



Execution:

Bearing surfaces honed.
Outside diameter fine-ground.

Note:

Headed Guide Bushes are to be held in H5-retainer bores.

Three screw clamps are provided for fixing; sizes Ø d1 = 38 mm and over have four.

FIBRO headed guide bushes for ball bearings are fully interchangeable with the corresponding sizes of the FIBRO headed guide bushes of sintered ferrite.

Notes on Sliding and Ball Bearing Guides see page D9.

Guide Pillars see pages D16, D17, D18, D22 and D35.

Ball guide capacity calculations see pages D56 and D57.

Material:

Bush: tool steel, Hardness: 62 ± 2HRC
Ball Cage: brass
Balls: hardened steel DIN 5401

2081.46.

d ₁	19 20	24 25	30 32	38 40	48 50	60 63	80
d ₂	25 26	30 31	38 40	46 48	56 58	68 71	92
d ₃	32	40	48	58	70	85	105
d ₄	32	40	48	58	70	85	105
d ₅	40	48	56	66	80	95	118
d ₆	52	60	67	77	91	106	129
d ₇	64,7	72,7	79,7	89,7	103,7	118,7	141,7
d ₈	39	46	53	63	77	92	115
a	20,7	22,65	24,4	35,3	40,2	45,5	54,5
a ₁	30	33,4	36,4	35,3	40,2	45,5	54,5
l ₁	43	59	75	82	97	116	120
l ₂	23	23	30	37	47	60	60
l ₃	20	36	45	45	50	56	60

206.71. (preferred length)

d ₁	19 20	24 25	30 32	38 40	48 50	60 63	80
l	56	71	95	105	120	140	140
l ₄	56	72	95	105	120	140	140

l = Nominal ordering length
l₄ = Manufacturing length

Ordering Code (example):

Headed Guide Bush =	2081.46.	Ball Cages =	206.71.	Tolerance yellow =	.10
d ₁ = 40 mm =	040.	d ₁ = 40 mm =	040.	range – green =	.20
Tolerance range-red =	30	l = 120 mm =	120	red =	.30
Order No =	2081.46.040.30	Order No =	206.71.040.120		

Headed Guide Bushes for Ball Bearings
DIN 9831/ISO 9448-7
Ball Cages

FIBRO
2081.47.
206.71.

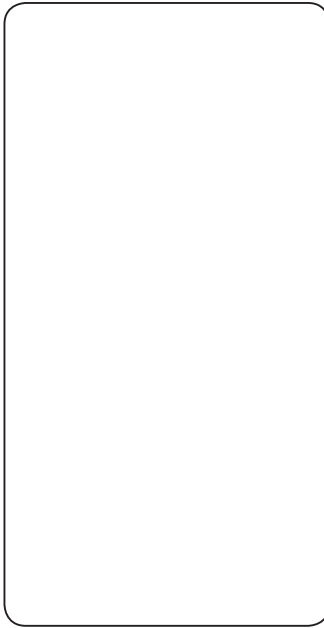
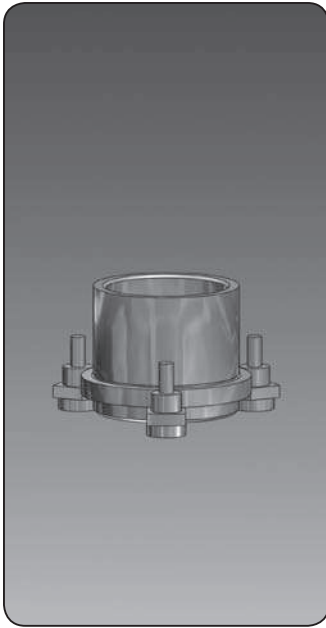

2081.47.

to order
separate:
Ball Cage
206.71.

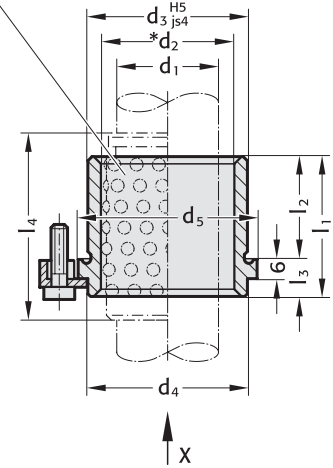

Execution:

Bearing surfaces honed.
Outside diameter fine-ground.

Note:

Headed Guide Bushes are to be held in H5-retainer bores.
Three screw clamps are provided for fixing; sizes $\varnothing d_1 = 38$ mm and over have four.
FIBRO headed guide bushes for ball bearings are fully interchangeable with the corresponding sizes of the FIBRO headed guide bushes of sintered ferrite.
Notes on Sliding and Ball Bearing Guides see page D 9.
Guide Pillars see pages D16, D17, D18, D22 and D35.
Ball guide capacity calculations see pages D56 and D57.

Material:

Bush: tool steel
Hardness: 62 ± 2 HRC
Ball Cage: brass
Balls: hardened steel DIN 5401

207.45

Order No for
replacement parts

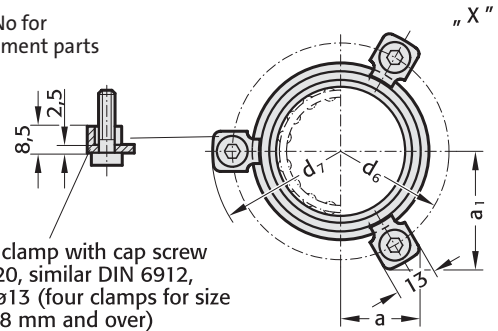

screw clamp with cap screw
M6 x 20, similar DIN 6912,
head $\varnothing 13$ (four clamps for size
 $d_1 = 38$ mm and over)

* Preloading see Colour Code Combinations – pages D10 and D11..

2081.47.

d_1	19 20	24 25	30 32	38 40	48 50	60 63	80
d_2	25 26	30 31	38 40	46 48	56 58	68 71	92
d_3	32	40	48	58	70	85	105
d_4	32	40	48	58	70	85	105
d_5	40	48	56	66	80	95	118
d_6	52	60	67	77	91	106	129
d_7	64,7	72,7	79,7	89,7	103,7	118,7	141,7
d_8	39	46	53	63	77	92	115
a	20,7	22,65	24,4	35,3	40,2	45,5	54,5
a_1	30	33,4	36,4	35,3	40,2	45,5	54,5
l_1	35	35	42	52	65	80	80
l_2	23	23	30	37	47	60	60
l_3	12	12	12	15	18	20	20

206.71. (preferred length)

d_1	19 20	24 25	30 32	38 40	48 50	60 63	80
l	45	45	56	63	80	95	120
l_4	44	44	55	65	80	95	119

l = Nominal ordering length
 l_4 = Manufacturing length

Ordering Code (example):

Headed Guide Bush = 2081.47.	Ball Cages = 206.71.	Tolerance yellow = .10
$d_1 = 40$ mm = 040.	$d_1 = 40$ mm = 040.	range – green = .20
Tolerance range- red = 30	l = 120 mm = 120	red = .30
Order No = 2081.47.040.30	Order No = 206.71.040.120	

FIBRO

2081.49.
206.71.

Headed Guide Bushes for Ball Bearings DIN 9831/ISO 9448-7 Ball Cages

2081.49.

to order
separate:
Ball Cage
206.71.

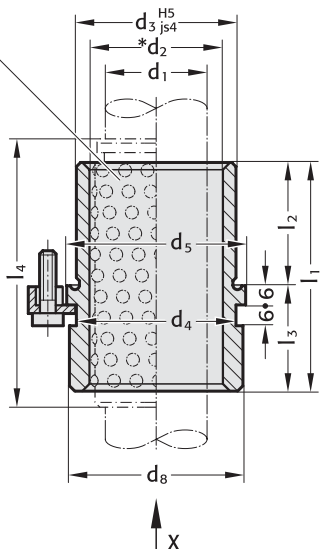

207.45

Order No for
replacement parts

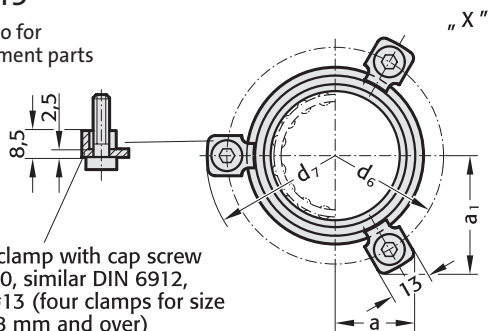

* Preloading see Colour Code Combinations – pages D10 and D11.

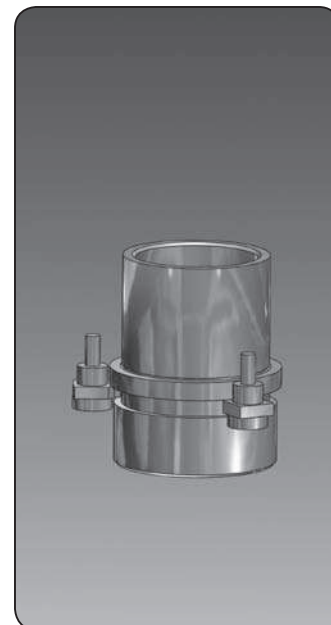

Execution:

Bearing surfaces honed.
Outside diameter fine-ground.

Note:

Headed Guide Bushes are to be held in H5-retainer bores.

Three screw clamps are provided for fixing; sizes $\text{Ø } d_1 = 38 \text{ mm}$ and over have four.

FIBRO headed guide bushes for ball bearings are fully interchangeable with the corresponding sizes of the FIBRO headed guide bushes of sintered ferrite.

Notes on Sliding and Ball Bearing Guides see page D 9.

Guide Pillars see pages D16, D17, D18, D22 and D35.

Ball guide capacity calculations see pages D56 and D57.

Material:

Bush: tool steel
Hardness: $62 \pm 2\text{HRC}$
Ball Cage: brass
Balls: hardened steel DIN 5401

2081.49.

d_1	24 25	30 32	38 40	48 50
d_2	30 31	38 40	46 48	56 58
d_3	40	48	58	70
d_4	40	48	58	70
d_5	48	56	66	80
d_6	60	67	77	91
d_7	72,7	79,7	89,7	103,7
d_8	46	53	63	77
a	22,65	24,4	35,3	40,2
a_1	33,4	36,4	35,3	40,2
l_1	55	69	79	96
l_2	30	37	47	60
l_3	25	32	32	36

206.71. (preferred length)

d_1	24 25	30 32	38 40	48 50
l	71	80	95	120
l_4	72	80	95	120

l = Nominal ordering length
 l_4 = Manufacturing length

Ordering Code(example):

Headed Guide Bush =	2081.49.	Ball Cages =	206.71.	Tolerance yellow =	.10
$d_1 = 40 \text{ mm}$ =	040.	$d_1 = 40 \text{ mm}$ =	040.	range – green =	.20
Tolerance range- red =	30	l = 120 mm =	120	red =	.30
Order No =	2081.49.040.30	Order No =	206.71.040.120		

Flanged Guide Bushes, sintered ferrite, DIN 9831/ISO9448-4, carbonitrided long-term lubrication

FIBRO

2091.31.



Mounting Examples

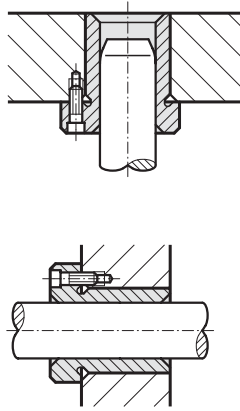

2091.31.

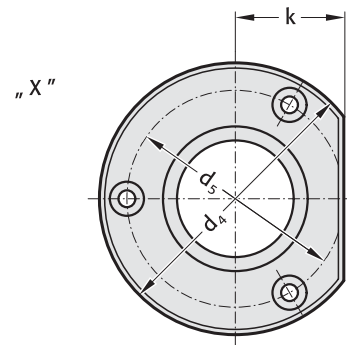
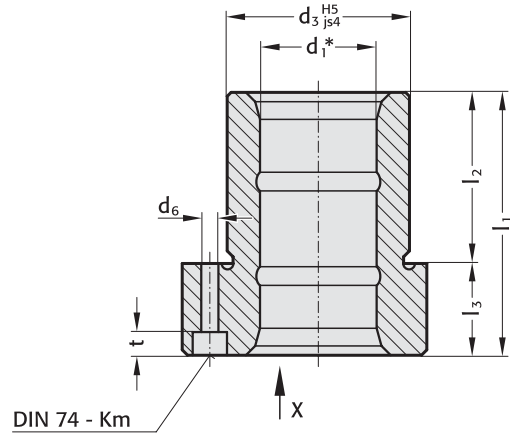

Material:

Sintered ferrite of high purity, carbonitrided.

Execution:

Bearing surfaces and outside diameter fine-ground.

Note:

Register bore H5.

The guide bush is fixed by means of 3 screws to DIN EN ISO 4762. The screws are not contained in the scope of delivery.

FIBRO flanged guide bushes of sintered ferrite carbonitrided are fully interchangeable with the corresponding sizes of the FIBRO flanged guide bushes for ball bearings.

Notes on Sliding- and Ball Bearing Guides: see page D9.

Guide Pillars: see pages D16, D17, D18, D22 and D35.

* Colour Code Combinations/Clearances – see pages D10 and D11.

2091.31.

d_1	19 20	24 25	30 32	38 40	48 50	60 63	80
d_3	32	40	48	58	70	85	105
d_4	50	63	72	85	104	120	148
d_5^*	40	50	58	70	86	100	125
d_6	4,5	5,5	5,5	6,6	9	9	11
k	18	23	28	33	38	46	56
l_1	52	62	72	77	102	102	125
l_2	37	37	47	47	60	60	75
l_3	15	25	25	30	42	42	50
t	4,6	5,7	5,7	6,8	9	9	11

Ordering Code (example):

Flanged Guide Bush	= 2091.31.	
$d_3 = 40$ mm	= 040.	Tolerance yellow = .10
Tolerance range – red	= 30	range – green = .20
Order No	= 2091.31.040.30	red = .30

FIBRO

**Flanged Guide Bushes, sintered ferrite,
DIN 9831/ISO 9448-4,
carbonitrided, long-term lubrication**

2091.32.

2091.32.

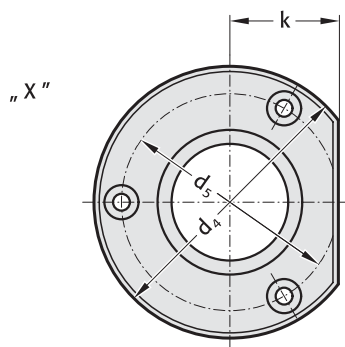
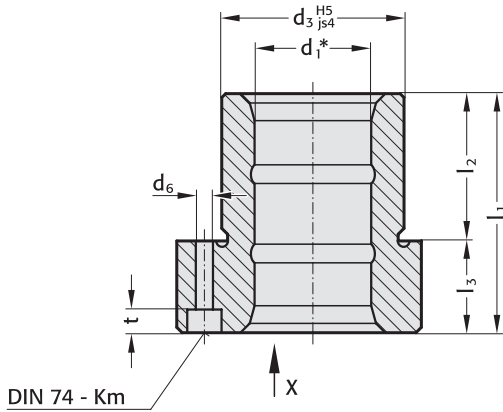

* Colour Code Combinations/Clearances – see pages D10 and D11.

Mounting Examples

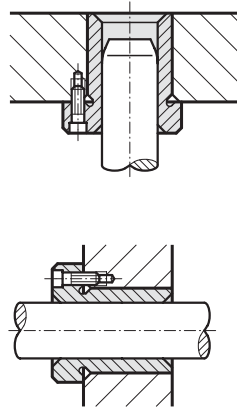

Material:

Sintered ferrite of high purity, carbonitrided

Execution:

Bearing surfaces and outside diameter fine-ground.

Note:

Register bore H5. The guide bush is fixed by means of 3 screws to DIN EN ISO 4762, except for dias. 15 + 16, which require screws to DIN 6912. The screws are not contained in the scope of delivery.

FIBRO flanged guide bushes of sintered ferrite carbonitrided are fully interchangeable with the corresponding sizes of the FIBRO flanged guide bushes for ball bearings.

Notes on Sliding- and Ball Bearing Guides: see page D9.

Guide Pillars: see pages D16, D17, D18, D22 and D35.

2091.32.

d ₁	15* 16*	19 20	24 25	30 32	38 40	48 50	60 63
d ₃	28	32	40	48	58	70	85
d ₄	45	50	63	72	85	104	120
d ₅ *	35	40	50	58	70	86	100
d ₆	4,5	4,5	5,5	5,5	6,6	9	9
k	15	18	23	28	33	38	46
l ₁	36	45	55	62	67	89	89
l ₂	30	30	30	37	37	47	47
l ₃	6	15	25	25	30	42	42
t	3,4	4,6	5,7	5,7	6,8	9	9

* use Shallow Head Cap Screws DIN 6912!

Ordering Code (example):

Flanged Guide Bush = 2091.32.

d₁ = 38 mm = 038.

Tolerance range – red = 30

Order No = 2091.32.038.30

Tolerance yellow = .10

range – green = .20

red = .30

2-100007-1 ©

Flanged Guide Bushes, sintered ferrite, DIN 9831/ISO 9448-4, carbonitrided, long-term lubrication

FIBRO

2091.34.

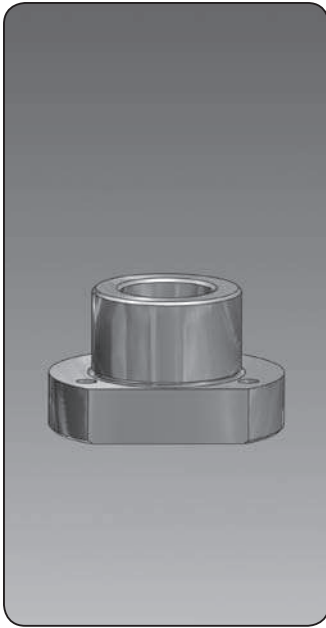

Mounting Examples

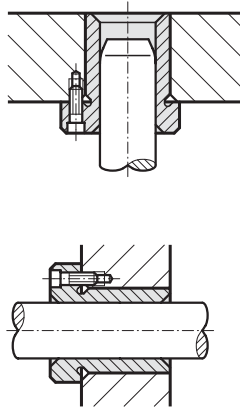

2091.34.

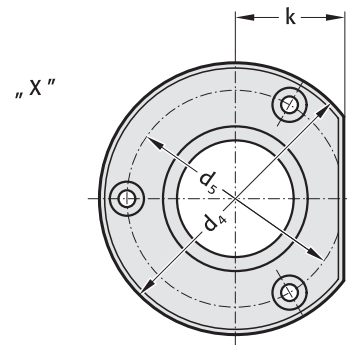
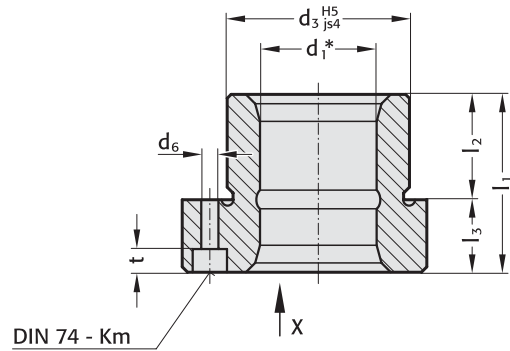

Material:

Sintered ferrite of high purity, carbonitrided.

Execution:

Bearing surfaces and outside diameter fine-ground.

Note:

Register bore H5. The guide bush is fixed by means of 3 screws to DIN EN ISO 4762, except for dias. 15 + 16, which require screws to DIN 6912. The screws are not contained in the scope of delivery.

FIBRO flanged guide bushes of sintered ferrite carbonitrided are fully interchangeable with the corresponding sizes of the FIBRO flanged guide bushes for ball bearings.

Notes on Sliding- and Ball Bearing Guides: see page D9.

Guide Pillars: see pages D16, D17, D18, D22 and D35.

* Colour Code Combinations/Clearances – see pages D10 and D11.

2091.34.

d_1	15* 16*	19 20	24 25	30 32	38 40	48 50
d_3	28	32	40	48	58	70
d_4	45	50	63	72	85	104
d_5^*	35	40	50	58	70	86
d_6	4,5	4,5	5,5	5,5	6,6	9
k	15	18	23	28	33	38
l1	29	38	38	45	55	62
l2	23	23	23	30	30	37
l3	6	15	15	15	25	25
t	3,4	4,6	5,7	5,7	6,8	9

* use Shallow Head Cap Screws DIN 6912!

Ordering Code (example):

Flanged Guide Bush	=	2091.34.	
$d_1 = 40$ mm	=	040.	
Tolerance range – red	=	30	Tolerance yellow = .10
Order No	=	2091.34.040.30	range – green = .20
			red = .30

FIBRO*ECO - LINE*

Flanged Guide Bushes

DIN 9831/ISO 9448

Bronze with Solid Lubrication Rings

2091.71.

2091.71.

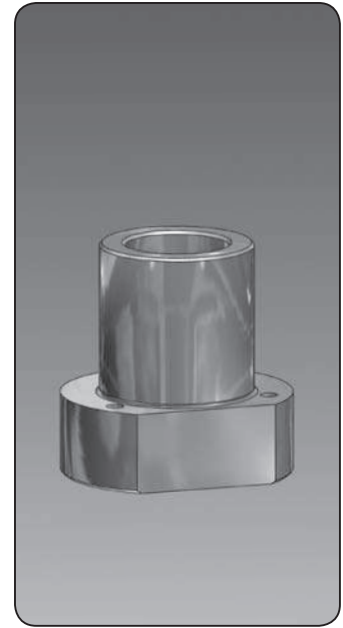
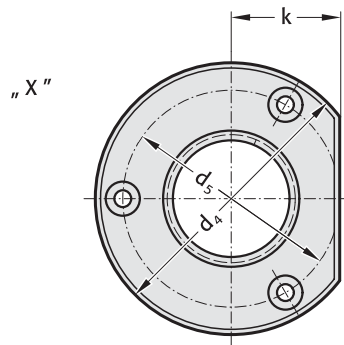
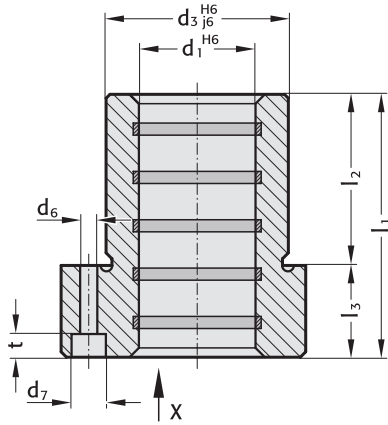
**Note:**

Register bore H6. The guide bush is fixed by means of 3 screws to DIN EN ISO 4762.
The screws are not contained in the scope of delivery.

Material:

Bronze

Execution:

Contact surfaces with solid lubricant rings.
Diameter d_3 and collar face precision ground.

2091.71.

d_1	19 20	24 25	30 32	38 40	48 50	60 63	80
d_3	32	40	48	58	70	85	105
d_4	50	63	72	85	104	120	148
d_5	40	50	58	70	86	100	125
d_6	4,5	5,5	5,5	6,6	9	9	11
d_7	8	10	10	11	15	15	18
k	18	23	28	33	38	46	56
l_1	52	62	72	77	102	102	125
l_2	37	37	47	47	60	60	75
l_3	15	25	25	30	42	42	50
t	4,6	5,7	5,7	6,8	9	9	11

Ordering Code (example):

Flanged Guide Bush = 2091.71.
 $d_1 = 40$ mm = 040
 Order No = 2091.71.040

Flanged Guide Bushes
DIN 9831/ISO 9448-4
Bronze with Solid Lubrication Rings

ECO-LINE

FIBRO

2091.72.

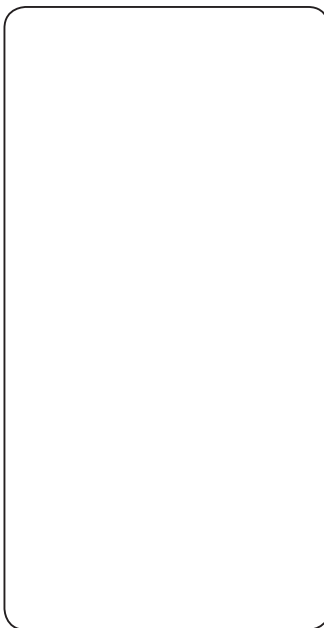
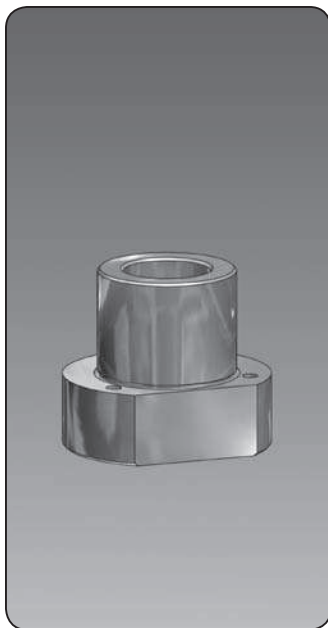

2091.72.

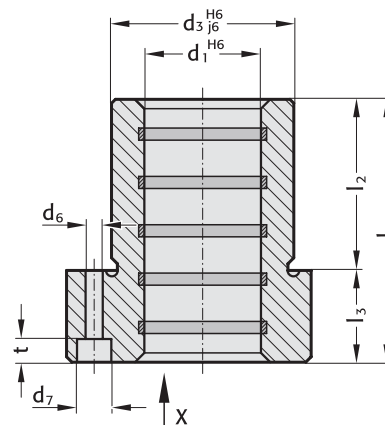

Note:

Register bore H6. The guide bush is fixed by means of 3 screws to DIN EN ISO 4762, except for dias. 15 + 16, which require screws to DIN 6912. The screws are not contained in the scope of delivery.

Material:

Bronze.

Execution:

Contact surfaces with solid lubricant rings.
Diameter d_3 and collar face precision ground.

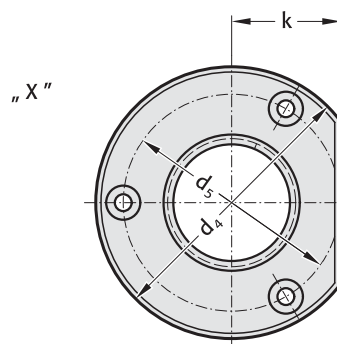

2091.72.

d_1	15* 16*	19 20	24 25	30 32	38 40	48 50	60 63
d_3	28	32	40	48	58	70	85
d_4	45	50	63	72	85	104	120
d_5	35	40	50	58	70	86	100
d_6	4,5	4,5	5,5	5,5	6,6	9	9
d_7	6	8	10	10	11	15	15
k	15	18	23	28	33	38	46
l_1	36	45	55	62	67	89	89
l_2	30	30	30	37	37	47	47
l_3	6	15	25	25	30	42	42
t	3,4	4,6	5,7	5,7	6,8	9	9

* use Shallow Head Cap Screws DIN 6912!

Ordering Code (example):

Flanged Guide Bush = 2091.72.
 $d_1 = 40$ mm = 040
Order No = 2091.72.040

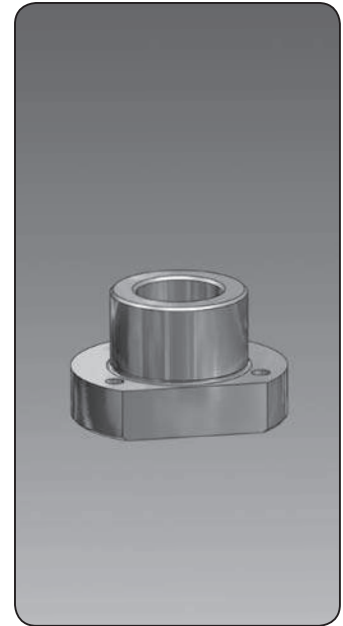
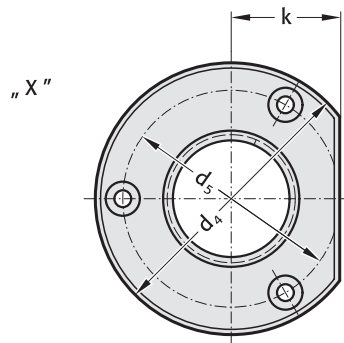
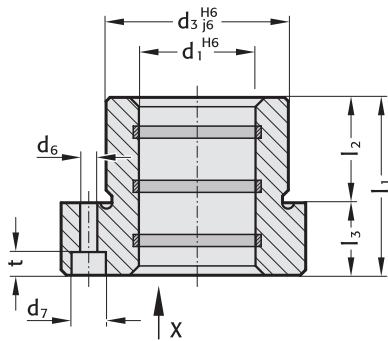
FIBRO*ECO - LINE***Flanged Guide Bushes****DIN 9831/ISO 9448-4****Bronze with Solid Lubrication Rings****2091.74.****2091.74.****Note:**

Register bore H6. The guide bush is fixed by means of 3 screws to DIN EN ISO 4762, except for dias. 15 + 16, which require screws to DIN 6912. The screws are not contained in the scope of delivery.

Material:

Bronze.

Execution:

Contact surfaces with solid lubricant rings.
Diameter d_3 and collar face precision ground.

2091.74.

d_1	15* 16*	19 20	24 25	30 32	38 40	48 50
d_3	28	32	40	48	58	70
d_4	45	50	63	72	85	104
d_5	35	40	50	58	70	86
d_6	4,5	4,5	5,5	5,5	6,6	9
d_7	6	8	10	10	11	15
k	15	18	23	28	33	38
l_1	29	38	38	45	55	62
l_2	23	23	23	30	30	37
l_3	6	15	15	15	25	25
t	3,4	4,6	5,7	5,7	6,8	9

* use Shallow Head Cap Screws DIN 6912!

Ordering Code (example):

Flanged Guide Bush = 2091.74.
 $d_1 = 40$ mm = 040
 Order No = 2091.74.040

Flanged Guide Bushes for Ball Bearings DIN 9831/ISO 9448-5 Ball Cages

FIBRO
2091.44.
206.71.



Mounting Examples

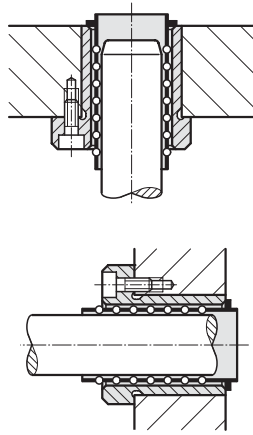

2091.44.

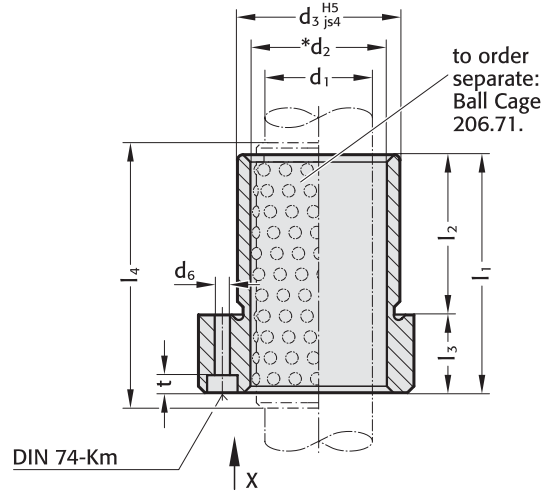

Material:

Bush: tool steel
Hardness: 62 ± 2 HRC
Ball Cage: brass
Balls: hardened steel DIN 5401

Execution:

Bearing surfaces honed. Outside diameter fine-ground.

Note:

Register bore H5. The guide bush is fixed by means of 3 screws to DIN EN ISO 4762. The screws are not contained in the scope of delivery.

FIBRO flanged guide bushes for ball bearings are fully interchangeable with the corresponding sizes of the FIBRO flanged guide bushes of sintered ferrite.

Notes on Sliding- and Ball Bearing Guides: page D9.

Guide Pillars: see pages D16, D17, D18, D22 and D35.

Ball guide capacity calculations see pages D56 and D57.

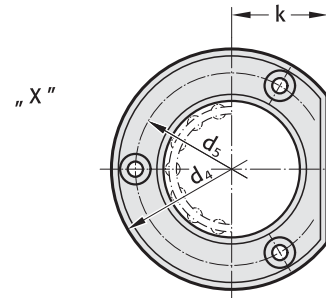

* Preloading see Colour Code Combinations – pages D10 and D11.

2091.44.

d ₁	19 20	24 25	30 32	38 40	48 50	60 63	80
d ₂	25 26	30 31	38 40	46 48	56 58	68 71	92
d ₃	32	40	48	58	70	85	105
d ₄	50	63	72	85	104	120	148
d ₅	40	50	58	70	86	100	125
d ₆	4,5	5,5	5,5	6,6	9	9	11
k	18	23	28	33	38	46	56
l ₁	52	62	72	77	102	102	125
l ₂	37	37	47	47	60	60	75
l ₃	15	25	25	30	42	42	50
t	4,6	5,7	5,7	6,8	9	9	11

206.71. (preferred length)

d ₁	19 20	24 25	30 32	38 40	48 50	60 63	80
l	71	71	80	95	120	120	140
l ₄	72	72	80	95	120	120	140

l = Nominal ordering length
l₄ = Manufacturing length

Ordering Code (example):

Flanged Guide Bush	= 2091.44.	Ball Cage	= 206.71.	Tolerance yellow	= .10
d ₁ = 40 mm	= 040.	d ₁ = 40 mm	= 040.	range – green	= .20
Tolerance range – green	= 20	l = 80 mm	= 080	red	= .30
Order No	= 2091.44.040.20	Order No	= 206.71.040.080		

FIBRO

2091.45.
206.71.

Flanged Guide Bushes for Ball Bearings DIN 9831/ISO 9448-5 Ball Cages

2091.45.

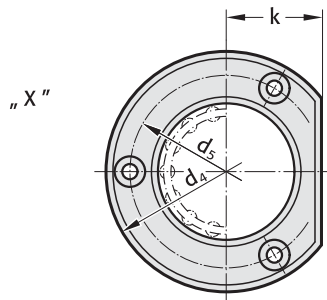
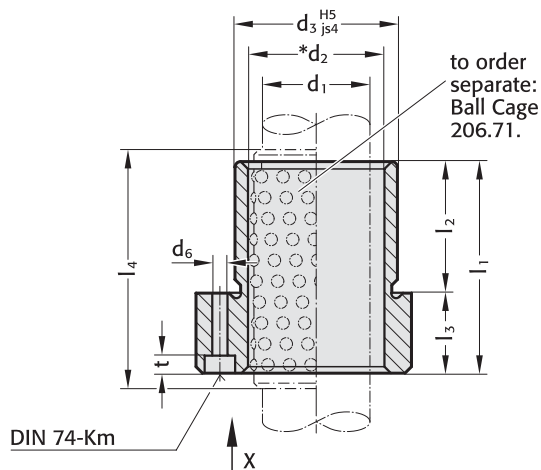

* Preloading see Colour Code Combinations – pages D10 and D11.

Mounting Examples

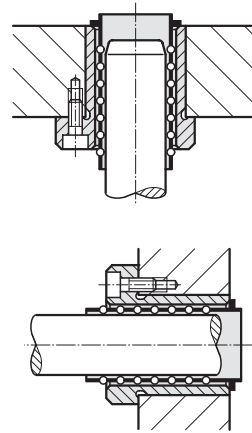

Material:

Bush: tool steel
Hardness: 62 ± 2 HRC
Ball Cage: brass
Balls: hardened steel DIN 5401

Execution:

Bearing surfaces honed. Outside diameter fine-ground.

Note:

Register bore H5. The guide bush is fixed by means of 3 screws to DIN EN ISO 4762, except for dias. 15 + 16, which require screws to DIN 6912. The screws are not contained in the scope of delivery.

FIBRO flanged guide bushes for ball bearings are fully interchangeable with the corresponding sizes of the FIBRO flanged guide bushes of sintered ferrite.

Notes on Sliding- and Ball Bearing Guides: page D9.

Guide Pillars: see pages D16, D17, D18, D22 and D35.

Ball guide capacity calculations see pages D56 and D57.

2091.45.

d ₁	15* 16*	19 20	24 25	30 32	38 40	48 50	60 63
d ₂	21 22	25 26	30 31	38 40	46 48	56 58	68 71
d ₃	28	32	40	48	58	70	85
d ₄	45	50	63	72	85	104	120
d ₅	35	40	50	58	70	86	100
d ₆	4,5	4,5	5,5	5,5	6,6	9	9
k	15	18	23	28	33	38	46
l ₁	36	45	55	62	67	89	89
l ₂	30	30	30	37	37	47	47
l ₃	6	15	25	25	30	42	42
t	3,4	4,6	5,7	5,7	6,8	9	9

206.71. (preferred length)

d ₁	15* 16*	19 20	24 25	30 32	38 40	48 50	60 63	* use Shallow Head Cap Screws DIN 6912!
l	45	56	71	71	80	95	95	l = Nominal ordering length
l ₄	44	56	72	70	80	95	95	l ₄ = Manufacturing length

Ordering Code (example):

Flanged								Tolerance yellow = .10
Guide Bush	= 2091.45.			Ball Cage	= 206.71.			range – green = .20
d ₁ = 40 mm	= 040.			d ₁ = 40 mm	= 040.			red = .30
Tolerance range – red	= 30			l = 120 mm	= 120			
Order No	= 2091.45.040.30			Order No	= 206.71.040.120			

Flanged Guide Bushes for Ball Bearings DIN 9831/ISO 9448-5 Ball Cages

FIBRO
2091.46.
206.71.



Mounting Examples

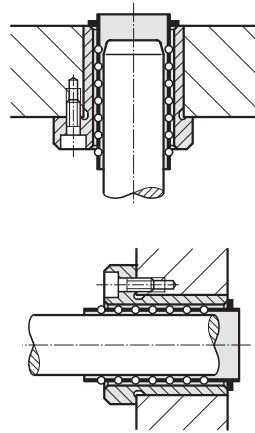

2091.46.

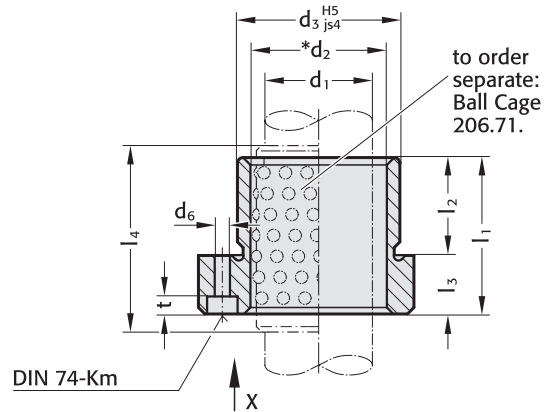

Material:

Bush: tool steel
Hardness: 62 ± 2 HRC
Ball Cage: brass
Balls: hardened steel DIN 5401

Execution:

Bearing surfaces honed. Outside diameter fine-ground.

Note:

Register bore H5. The guide bush is fixed by means of 3 screws to DIN EN ISO 4762, except for dias. 15 + 16, which require screws to DIN 6912. The screws are not contained in the scope of delivery.

FIBRO flanged guide bushes for ball bearings are fully interchangeable with the corresponding sizes of the FIBRO flanged guide bushes of sintered ferrite.

Notes on Sliding- and Ball Bearing Guides: page D9.

Guide Pillars: see pages D16, D17, D18, D22 and D35.

Ball guide capacity calculations see pages D56 and D57.

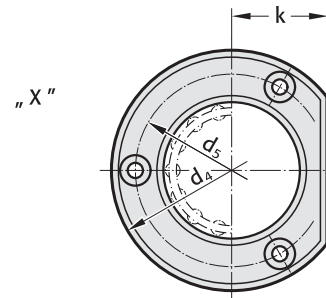

* Preloading see Colour Code Combinations – pages D10 and D11.

2091.46.

d ₁	12	15* 16*	19 20	24 25	30 32	38 40	48 50
d ₂	16	21 22	25 26	30 31	38 40	46 48	56 58
d ₃	26	28	32	40	48	58	70
d ₄	43	45	50	63	72	85	104
d ₅	33	35	40	50	58	70	86
d ₆	4,5	4,5	4,5	5,5	5,5	6,6	9
k	13	15	18	23	28	33	38
l ₁	25	29	38	38	45	55	62
l ₂	16	23	23	23	30	30	37
l ₃	9	6	15	15	15	25	25
t	4,6	3,4	4,6	5,7	5,7	6,8	9

206.71. (preferred length)

d ₁	12	15* 16*	19 20	24 25	30 32	38 40	48 50	* use Shallow Head Cap Screws DIN 6912!
l	40	45	45	45	56	63	80	l = Nominal ordering length
l ₄	39	44	44	44	55	65	80	l ₄ = Manufacturing length

Ordering Code (example):

Flanged Guide Bush	= 2091.46.	Ball Cage	= 206.71.	Tolerance yellow	= .10
d ₁ = 40 mm	= 040.	d ₁ = 40 mm	= 040.	range – green	= .20
Tolerance range – green	= 20	l = 120 mm	= 120	red	= .30
Order No	= 2091.46.040.20	Order No	= 206.71.040.120		

FIBRO

**Headed Guide Bushes, sintered ferrite,
similar AFNOR carbonitrided
long-term lubrication**

210.31.

210.31.

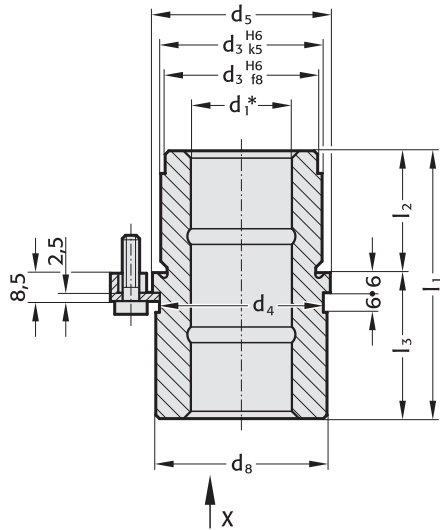

Mounting Examples

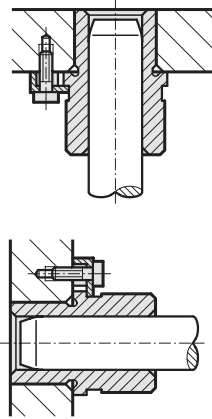

207.45

Order No for repeat-order.

Screw clamp with cap screw M6 x 20, similar DIN 6912, head Ø13, (four clamps for size d₁ = 40 mm and over)

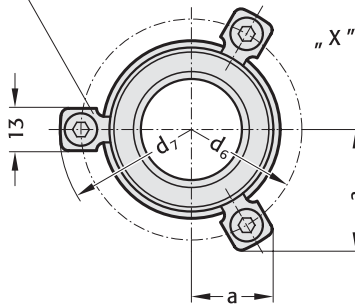

* Colour Code Combinations/Clearances – see pages D10 and D11.

Material:

Sintered ferrite of high purity, carbonitrided.

Execution:

Bearing surfaces and outside diameter fine-ground.

Note:

Headed Guide Bushes are to be held in H6-retainer bores. Three screw clamps are provided for fixing; sizes d₁ = 40 mm and over have four.

FIBRO headed guide bushes of sintered ferrite carbonitrided are fully interchangeable with the corresponding sizes of the FIBRO guide bushes for ball bearings.

Notes on Sliding- and Ball Bearing Guides: page D9.

Guide Pillars: see pages D16, D17, D18, D22 and D35.

These guide bushes are supplied complete with clamps and low-head socket cap screws similar DIN 6912, head Ø13.

210.31.

d ₁	19	20	25	32	40	50
d ₃	32	40	50	63	80	
d ₄	32	40	50	63	80	
d ₅	36	45	56	70	90	
d ₆	49	57	67	81	101	
d ₇	61,7	69,7	79,7	93,7	113,7	
d ₈	35	43,5	53	67	87	
a	19,9	21,9	24,4	36	43	
a ₁	28,6	32,1	36,4	36	43	
l ₁	66	70	83	98	120	
l ₂	30	30	38	48	61	
l ₃	36	40	45	50	59	

Ordering Code (example):

Headed Guide Bush = 210.31.

d₁ = 40 mm = 040.

Tolerance range-green = 20

Order No = 210.31.040.20

Tolerance yellow = .10

range – green = .20

red = .30

Headed Guide Bushes, sintered ferrite,
similar AFNOR
carbonitrided long-term lubrication

FIBRO

210.34.

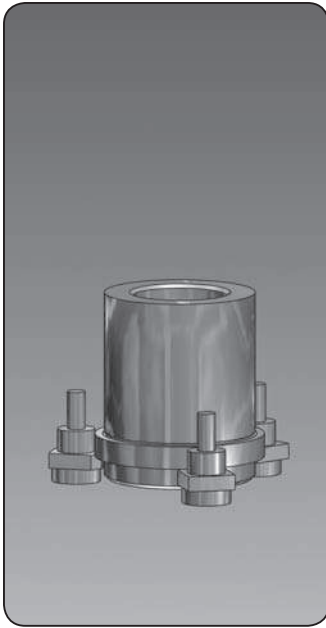

Mounting Examples

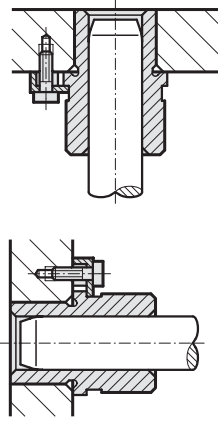

210.34.

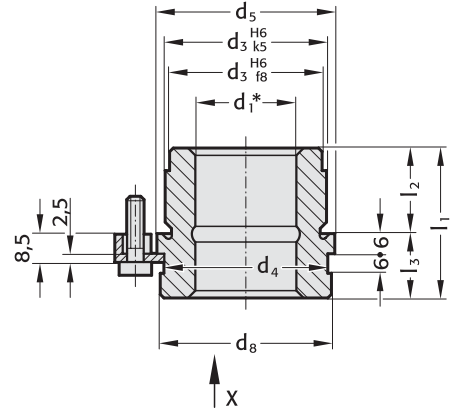

Material:

Sintered ferrite of high purity, carbonitrided.

Execution:

Bearing surfaces and outside diameter fine-ground.

Note:

Headed Guide Bushes are to be held in H6-retainer bores. Three screw clamps are provided for fixing; sizes $d_1 = 40$ mm and over have four.

FIBRO headed guide bushes of sintered ferrite carbonitrided are fully interchangeable with the corresponding sizes of the FIBRO guide bushes for ball bearings.

Notes on Sliding- and Ball Bearing Guides: page D9.

Guide Pillars: see pages D16, D17, D18, D22 and D35.

These guide bushes are supplied complete with clamps and low-head socket cap screws similar DIN 6912, head $\varnothing 13$.

207.45

Order No for repeat-order.

Screw clamp with cap screw M6 x 20, similar DIN 6912, head $\varnothing 13$, (four clamps for size $d_1 = 40$ mm and over)

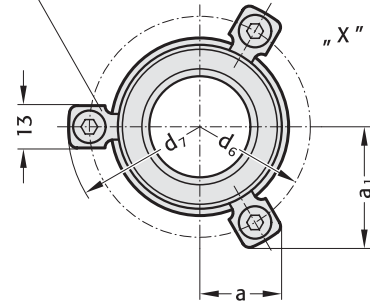

* Colour Code Combinations/Clearances – see pages D 10 and D 11.

210.34.

d_1	19 20	25	32	40	50
d_3	32	40	50	63	80
d_4	32	40	50	63	80
d_5	36	45	56	70	90
d_6	49	57	67	81	101
d_7	61,7	69,7	79,7	93,7	113,7
d_8	35	43,5	53	67	87
a	19,9	21,9	24,4	36	43
a_1	28,6	32,1	36,4	36	43
l_1	42	50	63	76	96
l_2	30	38	48	61	78
l_3	12	12	15	15	18

Ordering Code (example):

Headed Guide Bush = 210.34.

$d_1 = 40$ mm = 040.
Tolerance range – red = 30
Order No = 210.34.040.30

Tolerance yellow = .10
range – green = .20
red = .30

FIBRO

**Headed Guide Bushes, sintered ferrite,
similar AFNOR
carbonitrided long-term lubrication**

210.35.

210.35.

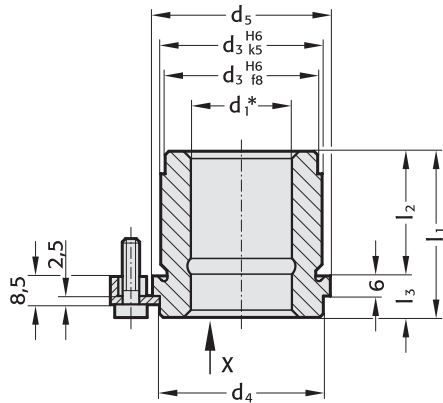

207.45

Order No for repeat-order.

Screw clamp with cap screw M6 x 20, similar DIN 6912, head Ø13, (four clamps for size d₁ = 40 mm and over)

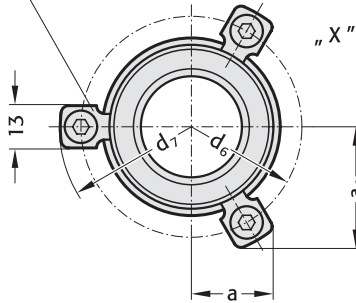

* Colour Code Combinations/Clearances – see pages D 10 and D 11.

Mounting Examples

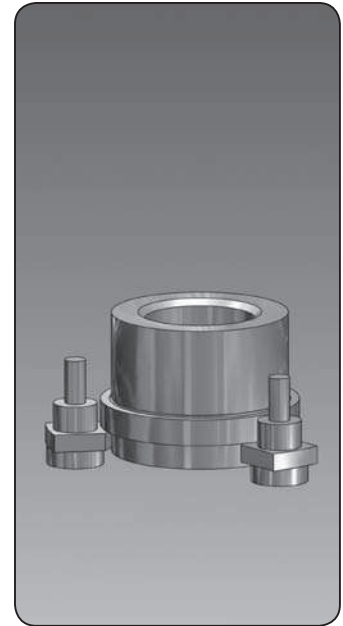
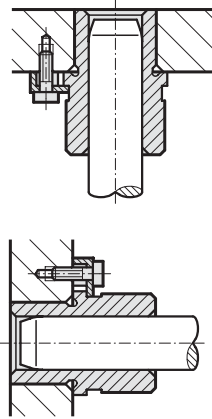

Material:

Sintered ferrite of high purity, carbonitrided.

Execution:

Bearing surfaces and outside diameter fine-ground.

Note:

Headed Guide Bushes are to be held in H6-retainer bores. Three screw clamps are provided for fixing; sizes d₁ = 40 mm and over have four.

FIBRO headed guide bushes of sintered ferrite carbonitrided are fully interchangeable with the corresponding sizes of the FIBRO guide bushes for ball bearings.

Notes on Sliding- and Ball Bearing Guides: page D9.

Guide Pillars: see pages D16, D17, D18, D22 and D35.

These guide bushes are supplied complete with clamps and low-head socket cap screws similar DIN 6912, head Ø13.

210.35.

d ₁	19	20	25	32	40	50
d ₃	32	40	50	63	80	
d ₄	32	40	50	63	80	
d ₅	36	45	56	70	90	
d ₆	49	57	67	81	101	
d ₇	61,7	69,7	79,7	93,7	113,7	
a	19,9	21,9	24,4	36	43	
a ₁	28,6	32,1	36,4	36	43	
l ₁	28	32	37	44	44	
l ₂	16	20	25	32	32	
l ₃	12	12	12	12	12	

Ordering Code (example):

Headed Guide Bush = 210.35.

d₁ = 40 mm = 040.
Tolerance range – red = 30
Order No = 210.35.040.30

Tolerance yellow = .10
range – green = .20
red = .30

Headed Guide Bushes for Ball Bearings similar AFNOR Ball Cages

FIBRO

210.44.

206.71.



Mounting Examples

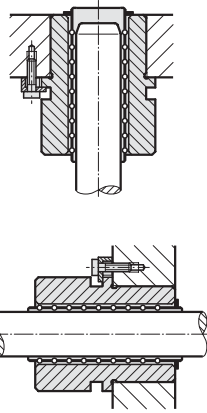

210.44.

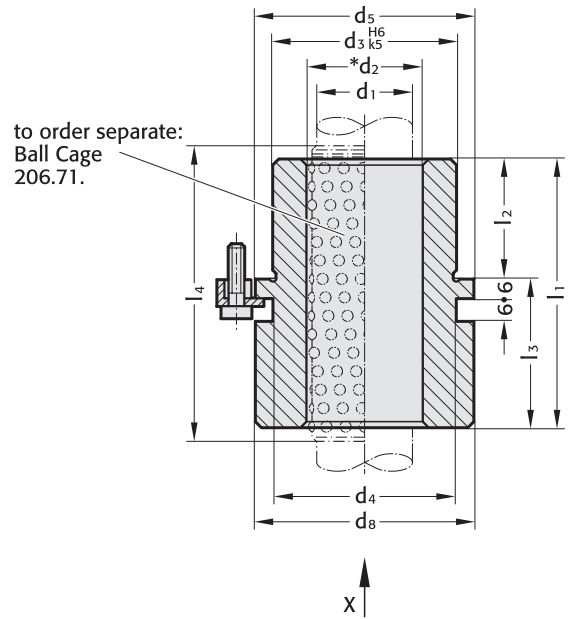

Material:

Guide Bush: tool steel
Hardness: 62 ± 2 HRC
Ball Cage: brass
Balls: hardened steel to DIN 5401

Execution:

Bearing surfaces honed.
Outside diameter fine-ground.

Note:

Receiving bores: H6 tolerance.
Guide bushes are retained by three screw clamps – sizes from $\varnothing d_1 = 40$ mm and over are supplied with four clamps.
FIBRO guide bushes for ball bearings are fully interchangeable with the corresponding sizes of the FIBRO guide bushes of sintered ferrite.
Notes on sliding- and rolling type guides see page D9.
For guide pillars see pages D16, D17, D18, D22 and D35.

207.45

Order No for repeat-order.

screw clamp with cap screws M6 x 20 similar DIN 6912, head $\varnothing 13$, (four clamps for size $d_1 = 40$ mm and over)

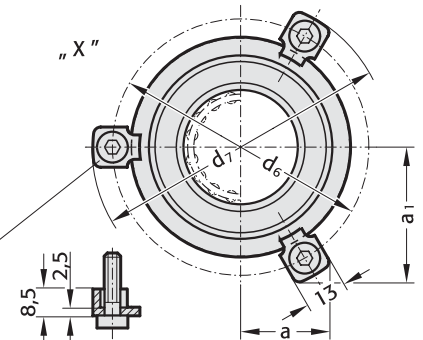

* Preloading see Colour Code Combinations – pages D10 and D11.

210.44.

d_1	16	20	25	32	40	50	63
l_3	32	36	40	45	50	63	63
l_2	l_1/l_4	l_1/l_4	l_1/l_4	l_1/l_4	l_1/l_4	l_1/l_4	l_1/l_4
23	55/63/64		63*/71/72	68*/80/80			
30	62/71/72	66/71/72	70/80/80	75*/80/80	80*/95/95		
38	70*/71/72	74/80/80	78/95/96	83/95/95	88*/95/95	101*/120/120	
48			88/95/96	93/105/105	98/105/105	111*/120/120	
61			101*/120/120	106/120/120	111/120/120	124/140/140	
78				123*/120/140	128/140/140	141/160/160	
98					148*/160/160	161*/180/180	161/180/180
123							186*/200/200

* not available ex-stock – supply on request!

l = Nominal ordering length

l_4 = Manufacturing length

Ordering Code (example):

Headed guide bush = 210.44.

$d_1 = 40$ mm = 040.

$l_2 = 30$ mm = 030.

Tolerance range – red = 30

Order No = 210.44.040.030.30

Ball Cage = 206.71.

$d_1 = 40$ mm = 040.

$l = 120$ mm = 120

Order No = 206.71.040.120

Tolerance yellow = .10

range – green = .20

red = .30

210.44./207.45

d_1	16	20	25	32	40	50	63
d_2	22	26	31	40	48	58	71
d_3	28	32	40	50	63	80	90
d_4	29	32	40	50	63	80	90
d_5	32	36	45	56	70	90	110
d_6	45	49	57	67	81	101	121
d_7	57,7	61,7	69,7	79,7	93,7	13,7	131,7
d_8	31	35	43,5	53,5	67	87	107
a	18,9	19,9	21,9	24,4	36	43	50,1
a_1	26,9	28,6	32,1	36,4	36	43	50,1

FIBRO

210.46.
206.71.

Headed Guide Bushes for Ball Bearings similar AFNOR Ball Cages

210.46.

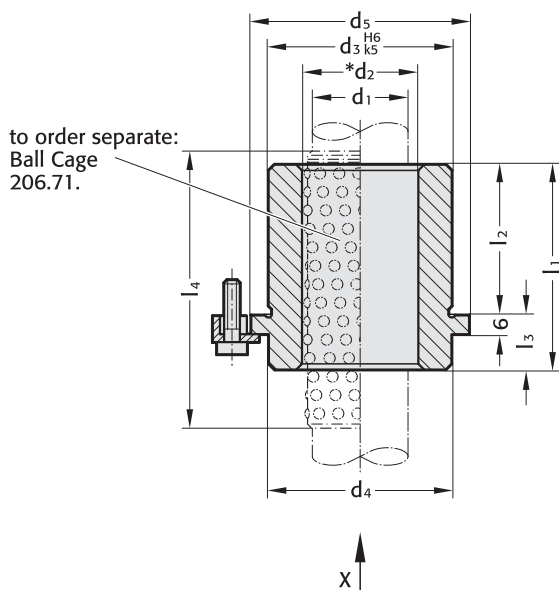

207.45

Order No
for repeat-order.

screw clamp
with cap screws
M6 x 20 similar
DIN 6912,
head $\varnothing 13$,
(four clamps for size
 $d_1 = 40$ mm and over)

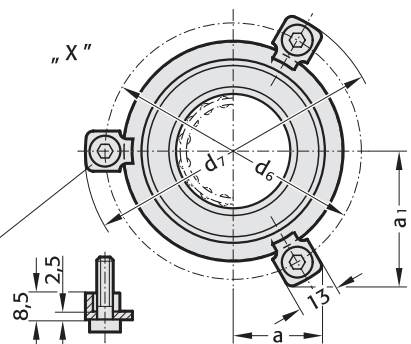

* Preloading see Colour Code Combinations – pages D10 and D11.

Mounting Examples

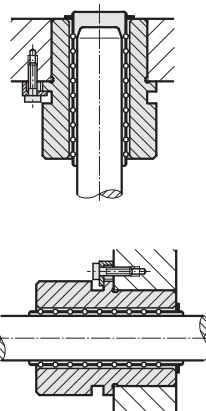

Material:

Guide Bush: tool steel
Hardness: 62 ± 2 HRC
Ball Cage: brass
Balls: hardened steel to DIN 5401

Execution:

Bearing surfaces honed.
Outside diameter fine-ground.

Note:

Receiving bores: H6 tolerance.
Guide bushes are retained by three screw clamps – sizes from $\varnothing d_1 = 40$ mm and over are supplied with four clamps.
FIBRO guide bushes for ball bearings are fully interchangeable with the corresponding sizes of the FIBRO guide bushes of sintered ferrite.

Notes on sliding- and rolling type guides see page D9.

For guide pillars see pages D16, D17, D18, D22 and D35.

210.46.

d_1	16	20	25	32	40	50	63
l_3	10	12	12	15	15	18	20
l_2	$l_1/l_1/l_4$	$l_1/l_1/l_4$	$l_1/l_1/l_4$	$l_1/l_1/l_4$	$l_1/l_1/l_4$	$l_1/l_1/l_4$	$l_1/l_1/l_4$
23	33/45/44						
30	40/45/44	42/45/44	42/45/44	45*/56/55			
38	48*/56/56	50/56/56	50/56/56	53*/71/70			
48	58*/63/64	60/71/72	60/71/72	63/71/70	63/80/80		
61		73*/80/80	76/80/80	76/95/95	79/95/95		
78		90*/105/105	93*/105/105	93*/105/105	96/105/105		
98			113*/120/120	113*/120/120	116*/140/140	118*/120/120	
123						143*/160/160	

* not available ex-stock – supply on request!

l = Nominal ordering length

l_4 = Manufacturing length

Ordering Code (example):

Headed guide bush = 210.46.

$d_1 = 40$ mm = 040.

$l_2 = 30$ mm = 030.

Tolerance range – red = 30

Order No = 210.46.040.030.30

Ball Cage = 206.71.

$d_1 = 40$ mm = 040.

$l = 120$ mm = 120

Order No = 206.71.040.120

Tolerance yellow = .10

range – green = .20

red = .30

210.46./207.45

d_1	16	20	25	32	40	50	63
d_2	22	26	31	40	48	58	71
d_3	28	32	40	50	63	80	90
d_4	29	32	40	50	63	80	90
d_5	32	36	45	56	70	90	110
d_6	45	49	57	67	81	101	121
d_7	57,7	61,7	69,7	79,7	93,7	113,7	131,7
d_8	31	35	43,5	53,5	67	87	107
a	18,9	9,9	21,9	24,4	36	43	50,1
a_1	26,9	28,6	32,1	36,4	36	43	50,1

Guide Bushes with Collar for Ball Bearings similar AFNOR

Ball Cages
Slotted Nuts

FIBRO

210.45. 206.71.

207.48.



Mounting Example

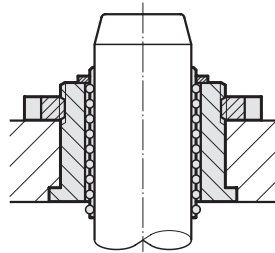

210.45.

to order separate:
Ball Cage 206.71.
Circlip 206.72.

to order separate:
Slotted Nut 207.48.

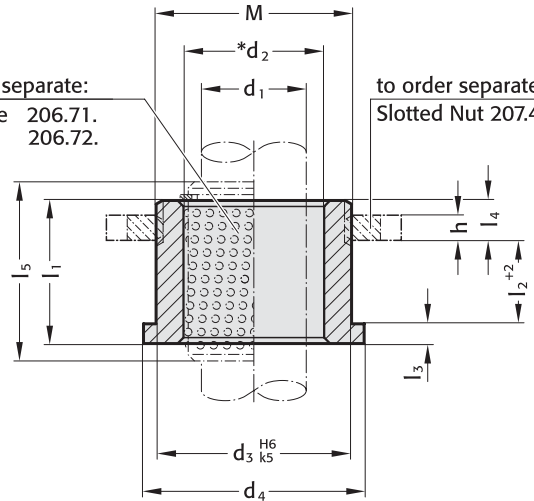

* Preloading see Colour Code Combinations – pages D10 and D11.

207.48.

Slotted Nut

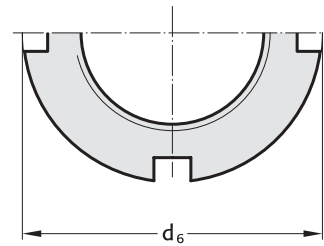

Material:

Guide Bush: tool steel
Hardness: 62 ± 2 HRC
Ball Cage: brass
Balls: hardened steel to DIN 5401

Execution:

Bearing surfaces fine-ground and honed.
Outside diameter fine-ground.

Note:

Receiving bore tolerance: H6.
The guide bushes are retained by slotted nuts.

210.45.

d ₁	16	20	25	32	40	50
d ₂	22	26	31	40	48	58
d ₃	28	32	40	50	63	80
d ₄	32	36	45	56	70	90
d ₆	40	44	55	65	81	100
M	M 27×1	M 30×1	M 39×1	M 48×1	M 60×1	M 76×1
h	3	4	4	5	6	8

l	24	24	31	40	50	50
l ₅	24	24	32	40	50	50
l ₁	16	17	22	26	32	41
l ₂	8	8	12	15	20	26

l	28	28	40	40	50	63
l ₅	28	28	40	40	50	65
l ₁	20	21	26	31	39	49
l ₂	12	12	16	20	27	34

l	–	31	40	50	56	–
l ₅	–	32	40	50	55	–
l ₁	–	25	31	38	47	–
l ₂	–	16	21	27	35	–

l ₃	3	3	3	4	4	5
l ₄	5	6	7	7	8	10

l = Nominal ordering length
l₅ = Manufacturing length
l₂ = assembly dimension

Ordering Code (example):

Guide Bushes	= 210.45.	Tolerance yellow = .10
d ₁ = 25 mm	= 025.	range – green = .20
l ₁ = 22 mm	= 022.	red = .30
Tolerance range – red	= 30	
Order No	= 210.45.025.022.30	

207.48.

Ordering Code (example):

Slotted Nut	= 207.48.
d ₁ = 40 mm	= 040
Order No	= 207.48.040

206.71. (Preferred length)

Ordering Code (example):

Ball Cage	= 206.71.
d ₁ = 40 mm	= 040
l = 56 mm	= 056
Order No	= 206.71.040.056

206.72.

Ordering Code (example):

Circlip	= 206.72.
d ₁ = 40 mm	= 040
Order No	= 206.72.040

FIBRO

210.85.
207.48.

Guide Bushes with Collar, Bronze-coated to AFNOR Slotted Nuts

210.85.

Guide Bush with Collar

to be ordered
separately:
Slotted Nut 207.48.

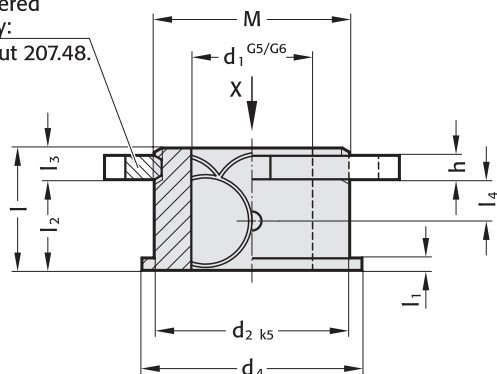

View X
without Slotted Nut

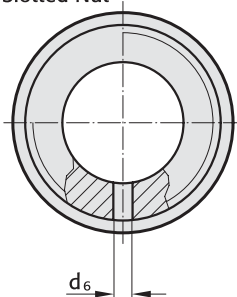

207.48.

Slotted Nut

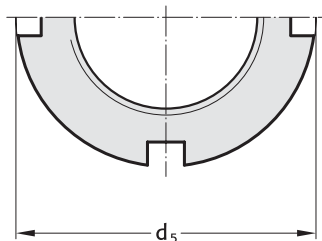

Mounting example:

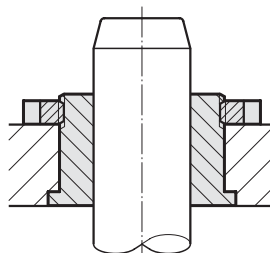

Note:

Receiving bore tolerance: H6

Guide pairing:

We recommend the use of guide pillars from pairing class .20/.30.

Material:

1.0503 (C45)

∅ d₂

induction hardened 500+100 HV 10

Execution:

Bronze coated internal bore
outside diameter fine ground.

∅ d₁ up to d₁ = 25 tolerance G6
from d₁ = 32 tolerance G5

210.85.

d ₁	16	20	25	32	40	50
tol.	+0,017 +0,006	+0,020 +0,007	+0,020 +0,007	+0,020 +0,009	+0,020 +0,009	+0,020 +0,009
d ₂	28	32	40	50	63	80
d ₄	32	36	45	56	70	90
d ₅	40	44	55	65	81	100
d ₆	3	4	4	4	7	7
h	3	4	4	5	6	8
M	M27×1	M30×1	M39×1	M48×1	M60×1	M76×1
l ₁	3	3	3	4	4	5
l ₂	11 15	15 19	19 24	24 31	31 39	31 39
l ₃	5	6	7	7	8	10
l ₄	5,5 7,5	7,5 9,5	9,5 12	12 15,5	15,5 19,5	15,5 19,5
l	16 20	21 25	26 31	31 38	39 47	41 49

Ordering Code (example):

Guide Bush = 210.85.
d₁ = 40 mm = 040.
l = 47 mm = 047
Order No = 210.85.040.047

Ordering Code (example):

Slotted Nut = 207.48.
d₁ = 40 mm = 040
Order No = 207.48.040

