

The image displays several components of a HepcoMotion BSP ballscrew premier system. In the foreground, there are two large ballscrews with their respective nuts. One nut is shown in a disassembled state, revealing the ballscrew shaft. A smaller, separate ballscrew shaft with a nut is also visible. The components are made of polished metal and are set against a light blue background.

**HepcoMotion®**

**BSP**  
ballscrew premier

**HEPCO®**  
[www.HepcoMotion.com](http://www.HepcoMotion.com)

## Contents

<b>INTRODUCING THE HepcoMotion® BSP</b>	<b>1</b>
<b>NUT/SCREW COMBINATIONS</b>	<b>2</b>
Accuracy	2
<b>SUPPLY OPTIONS</b>	<b>2</b>
<b>BSPS SERIES</b>	
Rapid Despatch Programme	3
<b>BSPH SERIES</b>	
High Lead Screws	4
<b>BSPM SERIES</b>	
Miniature Screws	5
<b>BHF BEARING HOUSING – FIXED END</b>	
To suit ballscrew end machining figure A	6
<b>BEK BEARING HOUSING – FIXED END</b>	
To suit ballscrew end machining figure A	7
<b>BEF &amp; BHS BEARING HOUSINGS – SUPPORTED END</b>	
To suit ballscrew end machining figure B	8
<b>SHAFT END MACHINING DETAILS</b>	<b>9</b>
<b>BALLSCREW SELECTION</b>	
1 Rotational Speed	10
2 Critical Speed	10
3 Buckling Load	11
4 Average Speed and Average Load	12
5 Service Life	12
6 Torque Calculation	12
<b>ORDERING DETAILS</b>	
Nut Part No.	13
Designation for End Machining - Nut Orientation	14
Screw Part No.	13
Designation for End Machining	14
Bearing Housing – Fixed Bearing end, to fit Fig A end machining	14
Bearing Housing – Supported Bearing end, to fit Fig B end machining	14

# Introducing the HepcoMotion® BSP Ballscrew Premier

**Ballscrew Premier offers a compact range of the more popular rolled and ground screws in single DIN nut format together with a range of high lead and miniature screws.**

**“Rapid despatch” screws identified in the catalogue as BSPS type are of single nut DIN flange design and incorporate rolled screws grade C7 with nuts either having controlled play A0 or no play A1. Select this range for most applications where medium accuracy is required with maximum convenience and a rapid delivery.**



**For the more preload critical application the same range can be offered with a ground screw C5 grade and a lightly preloaded single nut A2.**

**Complementing the range are high lead (BSPH) and miniature screws (BSPM) covering rolled C7 and ground C5 grades. Any combination of accuracy and preload can be offered across all types but, Ballscrew Premier has been designed to make selection easy to suit the majority of applications whilst maintaining competitive deliveries across the whole range.**

**For a complete list of the standard accuracy and preload combinations please refer to page 2**

## Nut/Screw combinations

Ballscrew Premier offers 3 types of nut, DIN single, High lead and Miniature all available on very competitive lead times. For maximum convenience select from the **“Rapid despatch programme” BSPS\*** which covers the popular combinations of rolled screws from 16mm to 40mm diameter.

If the combination you require is not listed then please call our Technical Department for availability.

Series	Type	Accuracy	Light Preload	No Play	Play
BSPS	DIN Single	C5 ground	A2		
BSPS*	DIN Single	C7 rolled		A1	A0
BSPH	High Lead	C5 ground		A1	
BSPH	High Lead	C7 rolled		A1	A0
BSPM	Miniature	C7 rolled			A0

### Accuracy

C5 ground screws have a maximum lead deviation of 0.018mm per 300mm

C7 rolled screws have a maximum lead deviation of 0.050mm per 300mm

## Supply options

Ballscrew units will be supplied with the ends machined and the nut assembled onto the screw. Disassembly of the nut from the screw is not possible without the aid of a special mandrel in order to release the nut and prevent the loss of the recirculating balls.

We do recommend, therefore that units are purchased with the ends ready machined to one of the standard configurations outlined in the catalogue using the relevant End Support bearing.

Machining to bespoke drawing requirements is possible, and screws without end machining can be supplied, however, it should be borne in mind that, in all cases, the nut will be assembled on to the screw and considerable care will need to be taken when machining in order to prevent the ingress of dirt into the recirculating system.

# BSPS Series

## Rapid Despatch Programme

DIN 69051 Form B

Single Nuts

Standard Availability

C7 Rolled\*

C5 Ground

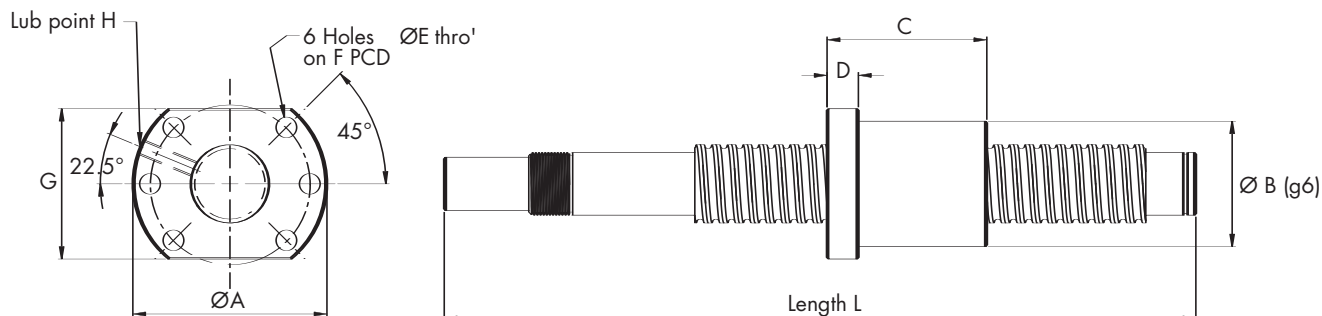

SD - Screw dia, P - Pitch, K - Stiffness (N/μm)

Nut Part number	Max length L (C5)	Max length L (C7) *	SD	P	A	B	C	D	E	F	G	H	Bas Dyn Ca(kN)	Bas Stat Coa(kN)	K
*BSPS1605R	800	2800	16	5	48	28	50	10	5.5	38	40	M6	7.8	17.9	200
(1)*BSPS1610R	800	2800	16	10	48	28	57	10	5.5	38	40	M6	7.21	12.49	150
(1)*BSPS2005R	1000	2800	20	5	58	36	51	10	6.6	47	44	M6	11.3	23.8	250
(1)*BSPS2505R	1500	2800	25	5	62	40	51	10	6.6	51	48	M6	12.8	31.1	350
*BSPS2510R	1500	2800	25	10	62	40	85	12	6.6	51	48	M6	19.4	38.7	330
(1)*BSPS3205R	1800	2800	32	5	80	50	52	12	9	65	62	M6	14.5	41.5	400
*BSPS3210R	1800	2800	32	10	80	50	90	12	9	65	62	M6	33.9	71.7	400
(1)*BSPS4005R	2000	2800	40	5	93	63	55	14	9	78	70	M8	16.1	53.3	490
*BSPS4010R	2000	2800	40	10	93	63	93	14	9	78	70	M8	39.1	95.2	500
BSPS5010R	2500	2800	50	10	110	75	93	16	11	93	85	M8	44.5	125.0	650

Nuts marked \* are part of the "Rapid Despatch Programme"

Nuts marked (1) can be supplied with left hand threads (not Rapid Despatch Programme)

Combinations C5 screw with light preload nut (A2)

C7 screw with no play nut (A1)

C7 screw with axial play nut (A0)

Axial play (A0) max figures: 16 – 40 dia 0.08mm, 50 dia 0.12mm

Screw diameters 25mm and above are available in lengths up to 6m by special request

If the combination you require is not listed Please check availability

# BSPH Series

## High Lead Screws

Single Nuts

Standard Availability

C7 Rolled

C5 Ground

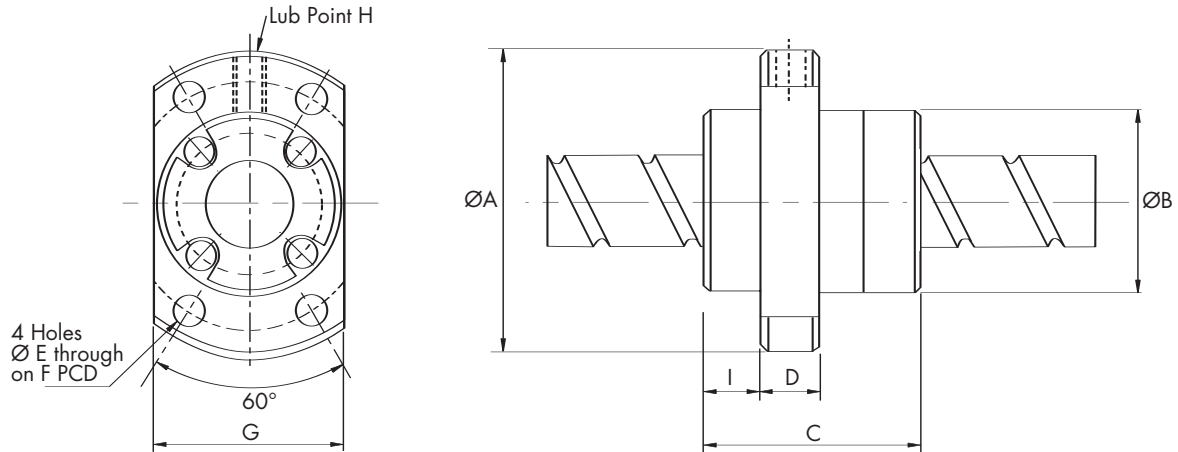

SD - Screw dia, P - Pitch, K - Stiffness (N/μm)

Nut Part number	Max length L (C5)	Max length L (C7)	SD	P	A	B	C	D	E	F	G	H	I	Bas Dyn Coa(kN)	Bas Stat Coa(kN)	K
BSPH1616R	800	2800	16	16	53	32	38	10	4.5	42	34	M6	10.1	6.5	12.8	190
BSPH2020R	800	2800	20	20	62	39	47	10	5.5	50	41	M6	11.5	9.8	21.4	250
BSPH2525R	1000	2800	25	25	74	47	57	12	6.6	60	49	M6	13	14.7	33.5	310
BSPH3232R	1500	2800	32	32	92	58	71	12	9	74	60	M6	16	21.4	52.6	400
BSPH4040R	1500	2800	40	40	114	73	89	15	11	93	75	M6	19	34.1	88.2	490
BSPH5050R	1800		50	50	135	90	107	20	14	112	92	M6	21.5	51.0	138.0	600

Please note BSPH 5050R is only available with ground screw C5

Combinations  
 C5 screw with no play nut (A1)  
 C7 screw with no play nut (A1)  
 C7 screw with axial play nut (A0)

Axial play (A0) max figures 16 – 40 dia 0.08mm, 50 dia 0.12mm

Screw diameters 25mm and above are available in lengths up to 6m by special request

If the combination you require is not listed Please check availability

# BSPM Series

## Miniature Series

Single Nuts

Standard Availability

C7 Rolled

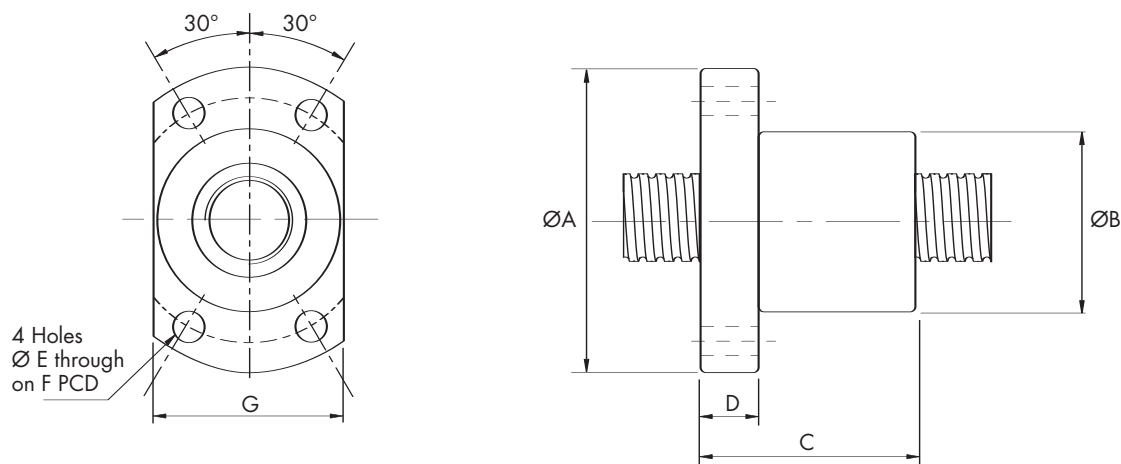

SD - Screw dia, P - Pitch, K - Stiffness (N/μm)

Nut Part number	Max length L (C5)	Max length L (C7)	SD	P	A	B	C	D	E	F	G	Bas Dyn Ca(κN)	Bas Stat Coa(κN)	K
BSPM0601R	150	150	6	1	24	12	15	3.5	3.4	18	16	0.73	1.21	55
BSPM0801R	200	200	8	1	27	14	16	4	3.4	21	18	0.93	1.73	72
BSPM08025R	200	200	8	2.5	29	16	26	4	3.4	23	20	1.77	2.78	79
BSPM1002R	300	300	10	2	35	18	28	5	4.5	27	22	1.85	3.05	90
BSPM1202R	500	600	12	2	37	20	28	5	4.5	29	24	1.73	3.17	110
BSPM1402R	500	700	14	2	40	21	23	6	5.5	31	26	2.87	6.33	120

All the above nuts can be supplied with left hand threads  
Lubrication hole for nut not supplied

Combinations C7 screw with axial play nut (A0)

Axial play (A0) max figure 0.05mm, all sizes

If the combination you require is not listed Please check availability

## BHF Bearing Housing – Fixed End

The HepcoMotion® BHF bearing housings are made from chemically blackened steel and contain a pair of matched angular contact bearings to provide accurate radial and axial location for the ballscrew. On installation, the locking nut should be fully tightened and locked in place using the grub screw. The standard ballscrew machined ends (see page 9) fit into these housings.

### To suit ballscrew end machining figure A

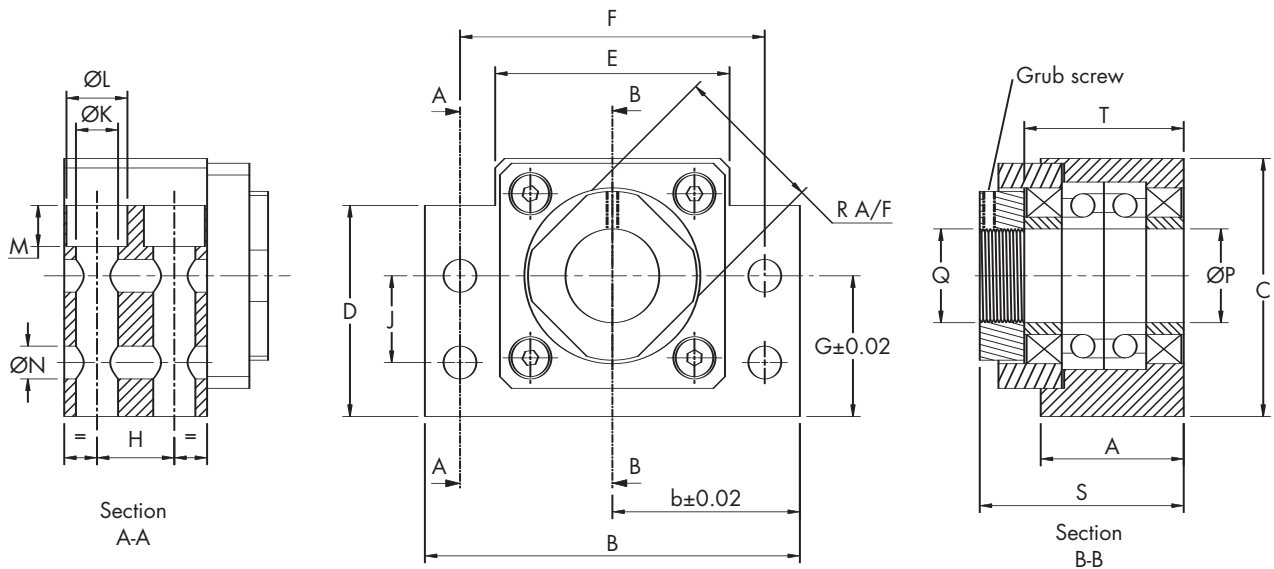

Ballscrew Diameter	Part No.	A	B	b	C	D	E	F	G	H	J	$\varnothing K$	$\varnothing L$	M	$\varnothing N$	$\varnothing P$	Q	R	S	T
16	BHF16	25	60	30	43	32.5	35	46	25	13	18	6.6	11	1.5	5.5	12	M12x1	19	34	26
20	BHF20	27	70	35	48	38	40	54	28	15	18	6.6	11	6.5	5.5	15	M15x1	22	38	30
25	BHF25	35	86	43	64	55	50	68	39	19	28	9	14	8.5	6.6	17	M17x1	24	51	38
32	BHF32	35	88	44	60	50	52	70	34	19	22	9	14	8.5	6.6	20	M20x1	30	51	40
40	BHF40	45	128	64	89	78	76	102	51	23	33	14	20	13	11	30	M30x1.5	40	70	50
50	BHF50	61	160	80	110	90	100	130	60	33	37	18	26	17.5	14	40	M40x1.5	50	91	66

### Ballscrew fitted with fixed and supported end bearings

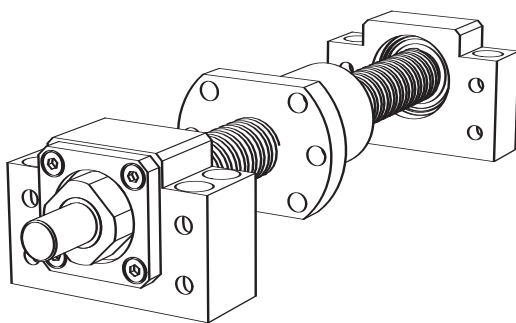

Fixed end

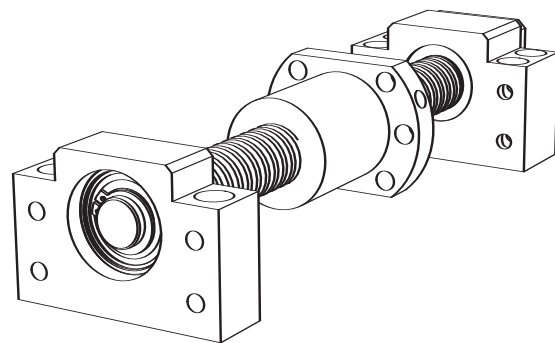

Supported end



# BEK Bearing Housing - Fixed End

The HepcoMotion® BEK bearing housings are made from chemically blackened steel and contain a pair of matched angular contact bearings to provide accurate radial and axial location for the ballscrew. On installation, the locking nut should be fully tightened and locked in place using the grub screw. The standard ballscrew machined ends (see page 9) fit into these housings.

## To suit ballscrew end machining figure A

BEK12 & BEK14

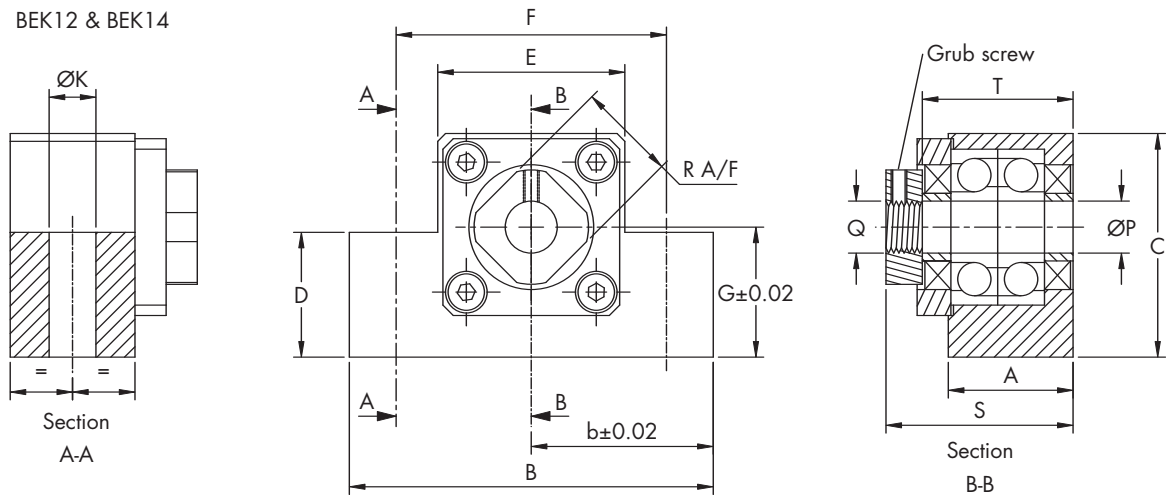

BEK8 & BEK10

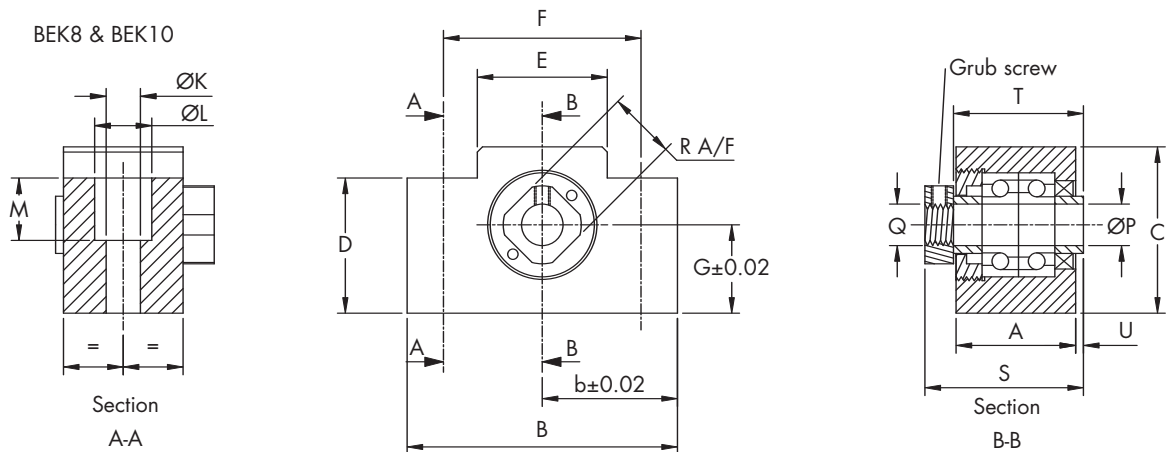

Ballscrew Diameter	Part No.	A	B	b	C	D	E	F	G	ØK	ØL	M	ØP	Q	R	S	T	U	
6	-	Standard housed bearing units are not available.																	
8	BEK8	20	42	21	25	20	18	30	13	5.5	9.5	11	6	M6x0.75	12	27	22	1.5	
10	BEK10	23	52	26	32	24	25	38	17	6.6	11	12	8	M8x1	14	31.3	25	1.3	
12	BEK12	24	70	35	43	24	36	52	25	9	-	-	10	M10x1	16	35.4	27	-	
14	BEK14	24	70	35	43	24	36	52	25	9	-	-	12	M12x1	19	35.3	27	-	

# BEF & BHS Bearing Housings - Supported End

The HepcoMotion® BEF & BHS bearing housings are made from chemically blacked steel and have an accurately machined bore into which a deep groove ball bearing is fitted. The bearing is a sliding fit in the bore, and is axially located onto the end of the ballscrew using a circlip, which is included with the unit. Units will fit ballscrews with ends machined to figure B on page 9.

## To suit ballscrew end machining figure B

BEF8 ... BEF1214

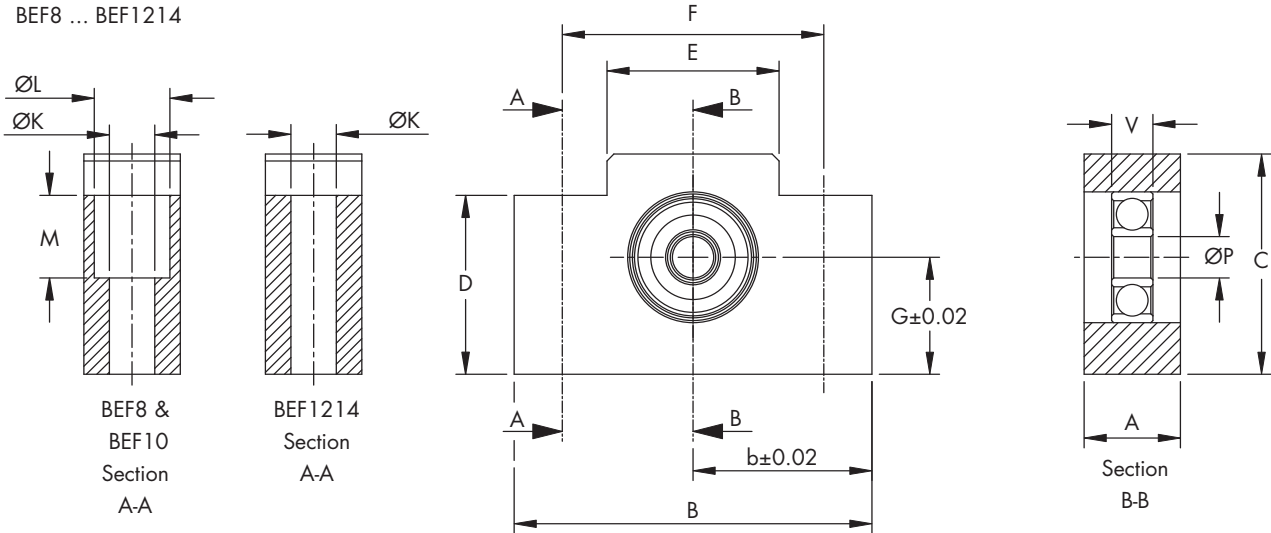

BHS16 ... BHS50

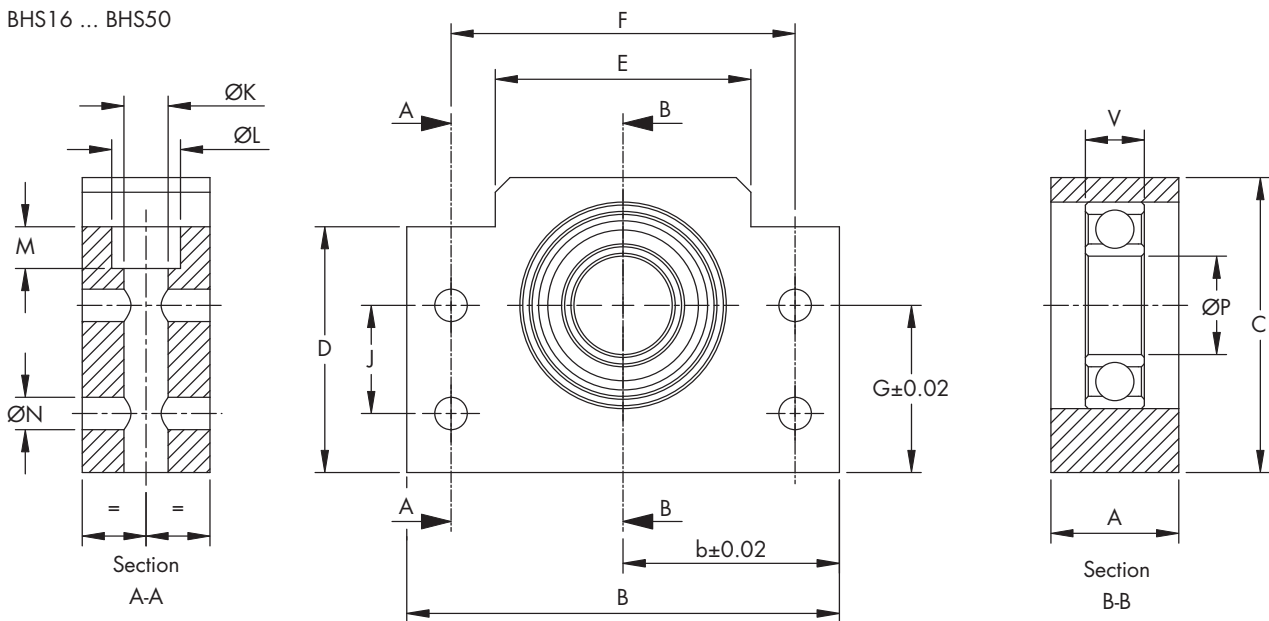

Ballscrew Diameter	Part No.	A	B	b	C	D	E	F	G	J	ØK	ØL	M	ØN	ØP	V	Bearing
6	-	Standard housed bearing units are not available.															
8	BEF8	12	42	21	25	20	18	30	13	-	5.5	9.5	11	-	6	6	606ZZ
10	BEF10	14	52	26	32	24	25	38	17	-	6.6	11	12	-	6	6	606ZZ
12 & 14	BEF1214	20	70	35	43	24	36	52	25	-	9	-	-	-	8	7	608ZZ
16	BHS16	20	60	30	43	32.5	35	46	25	18	6.6	11	1.5	5.5	10	8	6000ZZ
20	BHS20	20	70	35	48	38	40	54	28	18	6.6	11	6.5	5.5	15	9	6002ZZ
25	BHS25	23	86	43	64	55	50	68	39	28	9	14	8.5	6.6	17	12	6203ZZ
32	BHS32	26	88	44	60	50	52	70	34	22	9	14	8.5	6.6	20	12	6004ZZ
40	BHS40	32	128	64	89	78	76	102	51	33	14	20	13	11	30	16	6206ZZ
50	BHS50	37	160	80	110	90	100	130	60	37	18	26	17.5	14	40	18	6208ZZ

# Shaft End Machining Details

The following end machining details are to suit the fixed and supported bearing housings BHF, BHS, BEK & BEF shown in this catalogue.

Standard machining as details excludes a shaft keyway. If this feature is required, please indicate on a separate drawing showing size and position.

In addition we can machine ends to your requirements on receipt of a drawing.

Ballscrews with machined ends supplied under the "Rapid Despatch Programme" will have ends machined as detailed below, for use with BHF and BHS end support bearings.

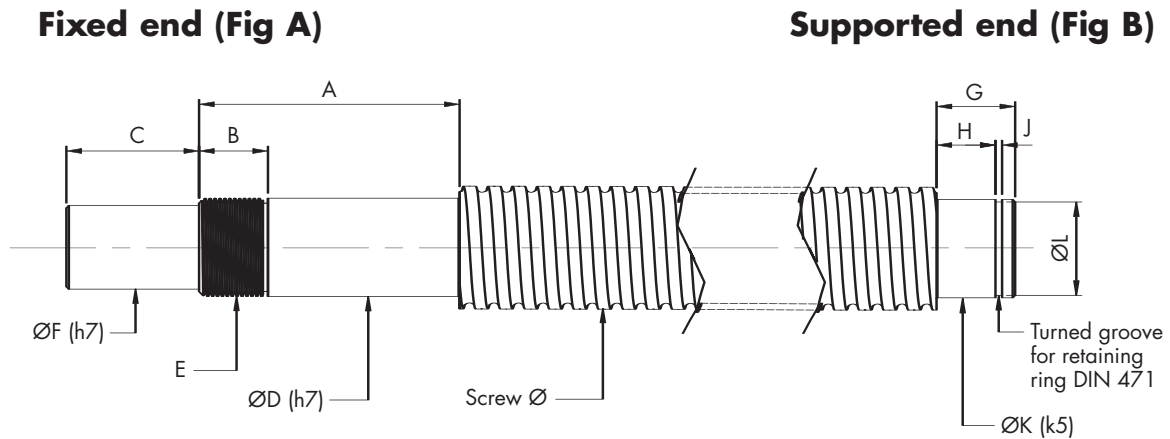

**Fixed end (Fig A)**

Use With	Screw Diameter	A	B	C	D	E	F
BEK8	8	29	9	8	6	M6x0.75	4
BEK10	10	34	11	10	8	M8x1	6
BEK12	12	38	13	15	10	M10x1	8
BEK14	14	38	13	15	12	M12x1	10
BHF16	16	39	15	19	12	M12x1	10
BHF20	20	43	15	20	15	M15x1	12
BHF25	25	56	20	25	17	M17x1	15
BHF32	32	56	18	35	20	M20x1	17
BHF40	40	75	28	43	30	M30x1.5	25
BHF50	50	98	35	50	40	M40x1.5	35

**Supported end (Fig B)**

Use With	Screw Diameter	G	H	J	K	L
BEF8	8	9	6	0.8	6	5.7
BEF10	10	9	6	0.8	6	5.7
BEF1214	12	10	7	0.9	8	7.6
	14					
BHS16	16	11	8	1.15	10	9.6
BHS20	20	13	9	1.15	15	14.3
BHS25	25	16	12	1.15	17	16.2
BHS32	32	16	12	1.35	20	19
BHS40	40	21	16	1.75	30	28.6
BHS50	50	23	18	1.95	40	38

**Note:** There is no standard end machining design for the Ø6 ballscrew, as Hepco does not stock housed bearing units for this size. Please submit a drawing showing details of your end machining requirements.

# Ballscrew Selection

## 1 Rotational Speed

The speed of a ballscrew is generally specified in terms of its linear velocity. The rotational speed is calculated using the following equation.

$$n = \frac{v}{p} \times 10^3$$

where  $n$  = rotational speed (rpm).  
 $v$  = linear velocity (m/min).  
 $p$  = lead (mm).

It is recommended that the speed does not exceed 3000rpm.

## 2 Critical Speed

The permissible maximum speed for any size and length of ballscrew depends on the diameter of the screw, end fixing and free length  $L$ , and can be taken from the chart below. The chart shows 4 speeds corresponding to the 4 mounting options and includes a safety factor of 25%.

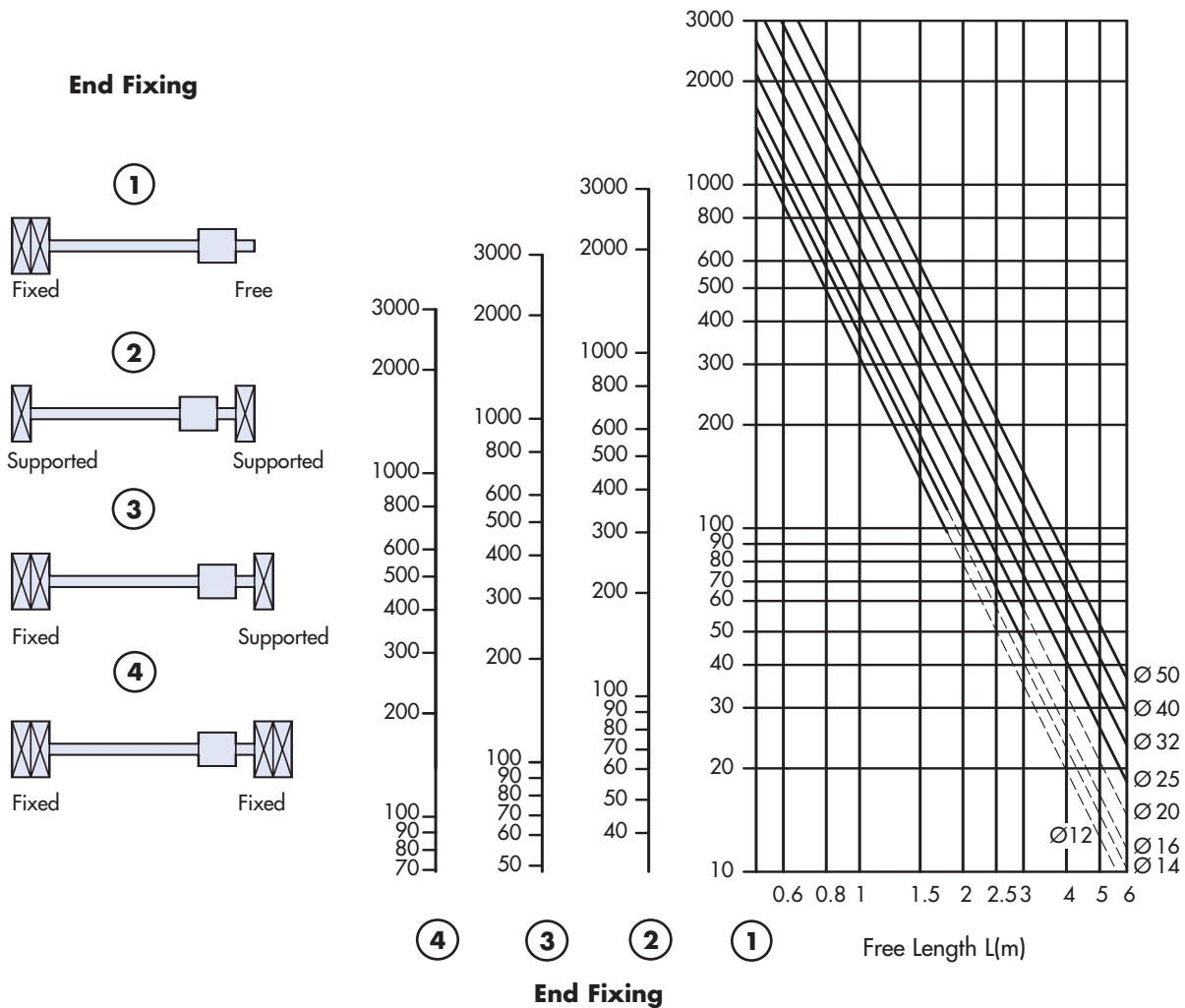

# Ballscrew Selection

## 3 Buckling Load

The maximum axial load which can be carried depends on the diameter of the ballscrew, end fixing and free length L. The buckling load for 4 different end fixings is shown below, the chart includes a safety factor of 100%.

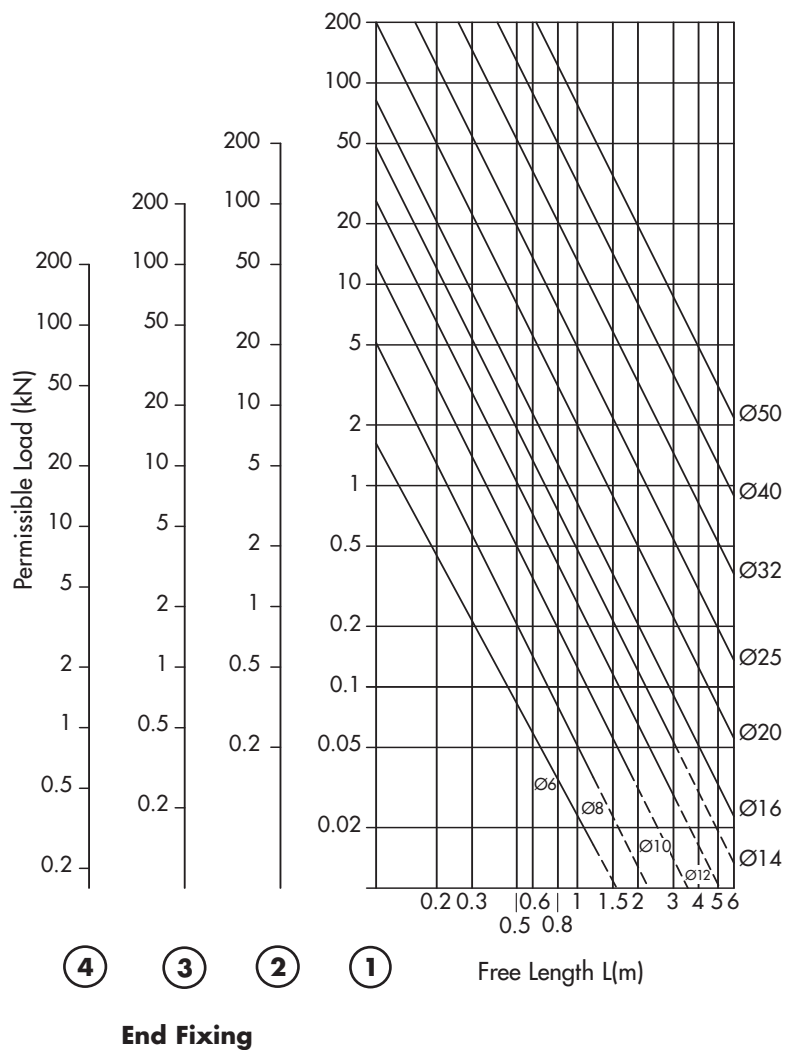
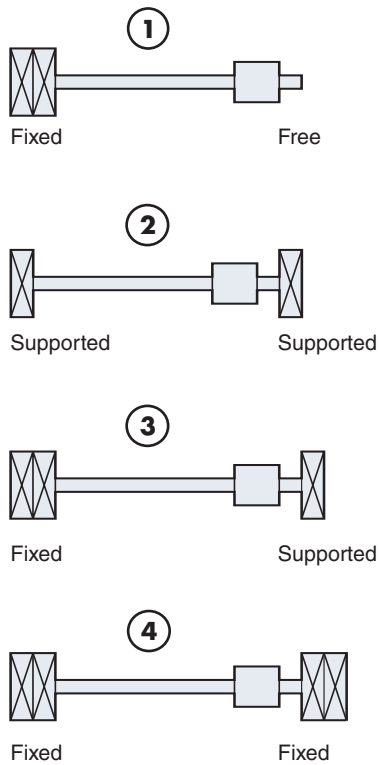

# Ballscrew Selection

## 4 Average Speed and Average Load

Where the speed varies through the machine cycle, average speed is calculated as follows:

$$n_m = \frac{q_1 \times n_1}{100} + \frac{q_2 \times n_2}{100} + \dots + \frac{q_x \times n_x}{100}$$

where  $n_m$  = average speed (rpm)  
 $q$  = time fraction (%)

Where the load varies, the average load is calculated as follows:

$$F_m = 3 \sqrt{\frac{F_1^3 \times q_1}{100} + \frac{F_2^3 \times q_2}{100} + \dots + \frac{F_x^3 \times q_x}{100}}$$

where  $F_m$  = average load

Where the load and speed varies, the average load is calculated as follows:

$$F_m = 3 \sqrt{\frac{F_1^3 \times n_1 \times q_1}{n_m \times 100} + \frac{F_2^3 \times n_2 \times q_2}{n_m \times 100} + \dots + \frac{F_x^3 \times n_x \times q_x}{n_m \times 100}}$$

## 5 Service Life

The basic life is expressed by the number of revolutions that will be attained or exceeded by 90% of a representative sample of identical ballscrews before the first signs of material fatigue become evident. Life in hours can be calculated by using the average speed.

$$L_{10} = \left( \frac{Ca}{F_m} \right)^3 \times 10^6 \quad \text{where } L_{10} = \text{service life (revolutions)}$$

$F_m$  = average load (kN)  
 $Ca$  = dynamic capacity (kN)

$$L_h = \frac{L_{10}}{60n_m} \quad \text{where } L_h = \text{service life (hours)}$$

## 6 Torque Calculation

Input torque for conversion of rotary motion to linear motion:

$$T_{in} = \frac{F \times P}{2000 \times \pi \times \eta} \quad \text{where } T_{in} = \text{drive torque (Nm)}$$

$F$  = operating load (N)  
 $P$  = lead (mm)  
 $\eta$  = efficiency (approx 0.9)

Output torque for conversion of linear motion to rotary motion:

$$T_{out} = \frac{F \times P \times \eta'}{2000 \times \pi} \quad \text{where } T_{out} = \text{transmitted torque}$$

$\eta'$  = efficiency (approx 0.8)

## Ordering Details

Specify the nut type BSPS, BSPH or BSPM along with the dia and pitch, accuracy and running code followed by the screw to match with end machining details.

All the screw references regardless of nut type are BSP.

The Ballscrew unit will be supplied assembled with ends machined ready for mounting, or assembled with plain ends according to customers order.

End bearing units are supplied separately.

### Nut Part No.

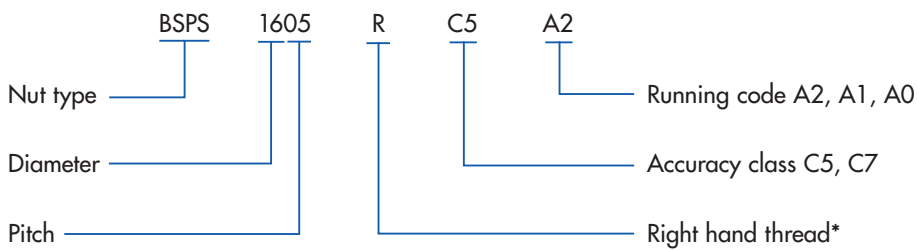

### Screw Part No.

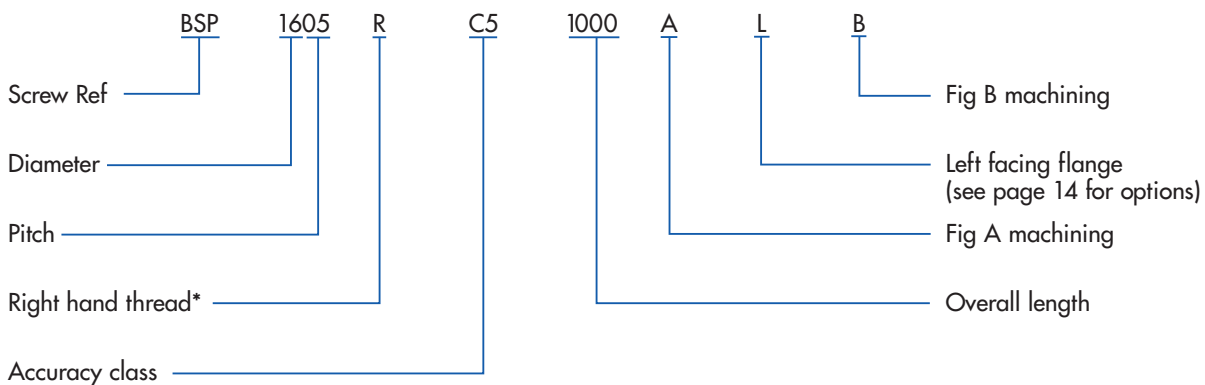

\* Some screws are available with left hand threads, these are clearly marked in the data/dimension tables. To specify a left hand thread use designation L instead of R

# Ordering Details

## Designation for End Machining - Nut Orientation

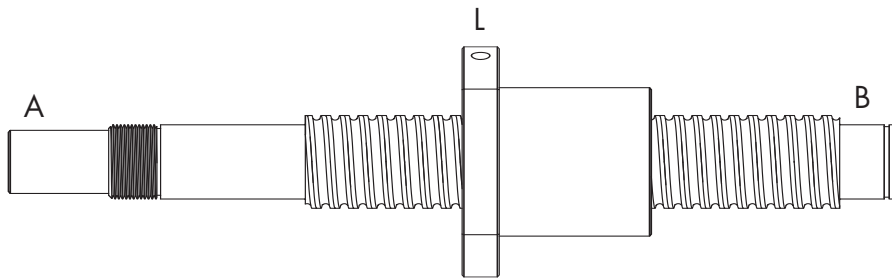

Example 1.  
Nut flange left position with  
standard machining – ALB

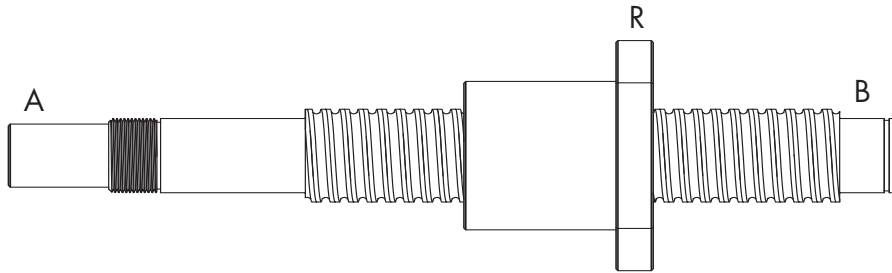

Example 2.  
Nut flange right position with  
standard machining – ARB

For plain ends with no machining delete ALB or ARB (Ref ordering details)

## Bearing Housing – Fixed Bearing end, to fit Fig A end machining

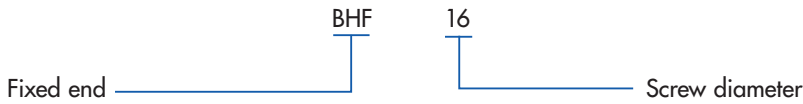

## Bearing Housing – Supported Bearing end, to fit Fig B end machining







# HepcoMotion® Product Range



**GV3**  
Linear Guidance and  
Transmission System



**HDS**  
Heavy Duty Slide System

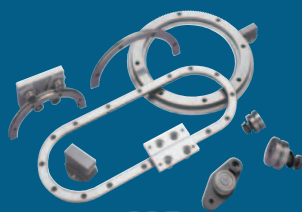

**PRT**  
Ring Slides and  
Track System



**SL2**  
Stainless Steel Based  
Slide System

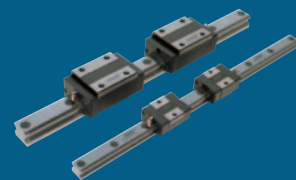

**LBG**  
Linear Ball Guides

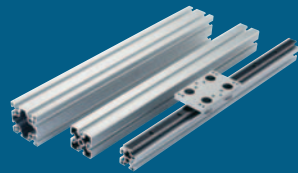

**MCS**  
Aluminium Frame and  
Machine Construction System

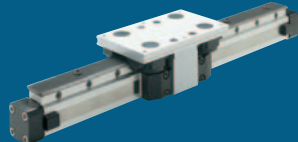

**HPS**  
Powerslide-2 Guided  
Rodless Cylinder



**HDLS**  
Heavy Duty Driven  
Linear System



**DLS**  
Linear Transmission and  
Positioning System



**HTS**  
Telescopic Ball  
Bearing Slides

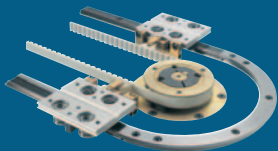

**DTS**  
Driven Track System



**BSP**  
Ballscrew Premier



**SimpleSelect®**  
Vee Slide Linear  
Guidance Systems

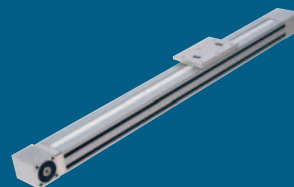

**PDU2**  
Profile Driven Unit

## BishopWisecarver Product Range

HepcoMotion® – Exclusive European partners and distributors for Bishop-Wisecarver since 1984.

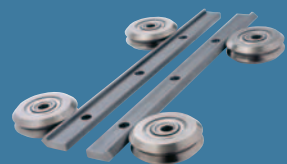

**DUAL VEE**  
Single Edge Slide System

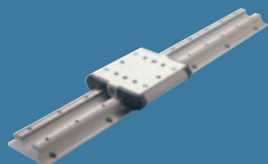

**LoPro**  
Aluminium Based  
Slide System

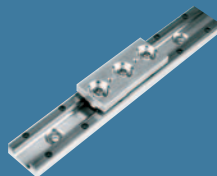

**Utilitrak**  
Lightweight U Channel  
Guideway

For further information on HepcoMotion® products –  
please request our leaflet 'FPL'

**HEPCO®**  
[www.HepcoMotion.com](http://www.HepcoMotion.com)

**HepcoMotion®**

Lower Moor Business Park, Tiverton Way, Tiverton, Devon, England EX16 6TG

Tel: +44 (0)1884 257000 Fax: +44 (0)1884 243500

[sales@hepcotion.com](mailto:sales@hepcotion.com)

CATALOGUE No. BSP 01 UK © 2004 Hepco Slide Systems Ltd.

Reproduction in whole or part without prior authorisation from Hepco is prohibited. Although every effort has been made to ensure the accuracy of the information in this catalogue, Hepco cannot accept liability for any omissions or errors. Hepco reserves the right to make alterations to the product resulting from technical developments.

Many Hepco products are protected by: Patents, Copyright, Design Right or Registered Design. Infringement is strictly prohibited and may be challenged in law. The Customer's attention is drawn to the following clause in Hepco's conditions of sale:

'It shall be the Customer's sole responsibility to ensure that goods supplied by Hepco will be suitable or fit for any particular application or purpose of the Customer, whether or not such application or purpose is known to Hepco. The Customer will be solely responsible for any errors in, or omissions from, any specifications or information the Customer provides. Hepco will not be obliged to verify whether any such specifications or information are correct or sufficient for any application or purpose.'

Hepco's full conditions of sale are available on request and will apply to all quotations and contracts for the supply of items detailed in this catalogue.

HepcoMotion is the trading name of Hepco Slide Systems Ltd.



INVESTOR IN PEOPLE

